



Bm Industrie

Éléments de moules

Punzoni - Punches - Poinçons - Lochstempel DIN 9861 WS - DA	pag.	1
Punzoni - Punches - Poinçons - Lochstempel DIN 9861 HWS - D/ HSS - D	pag.	2
Punzoni - Punches - Poinçons - Lochstempel DIN 9861 ASP 2023-D	pag.	3
Punzoni - Punches - Poinçons - Lochstempel DIN 9861 HSS-D L. 130/160/200	pag.	4
Espulsori per viti - Upsetting ejector pins - Poinçons pour visserie - Vorstaucher-Auswerferstifte DIN 9861 D-HSS	pag.	5
Punzoni F.C. - Punches F.C. - Poinçons F.C. - Lochstempel F.C. DIN 9861	pag.	6
Punzoni ISO 8020 - Punches ISO 8020 - Poinçons ISO 8020 - Lochstempel ISO 8020	pag.	7
Punzoni ISO 8020 F.C. - Punches ISO 8020 F.C. - Poinçons ISO 8020 F.C. - Lochstempel ISO 8020 F.C.	pag.	8
Punzoni ISO 8020 forati - Punches ISO 8020 with ejector pin - Poinçons ISO 8020 à éjecteur central - Lochstempel ISO 8020 mit Abstoßer	pag.	9
Punzoni ISO 8020 forati F.C. - Punches ISO 8020 with ejector pin F.C. - Poinçons ISO 8020 à éjecteur central F.C. - Lochstempel ISO 8020 mit Abstoßer F.C.	pag.	10
Punzoni sagomati a richiesta - Special punches on request - Poinçons speciales sur demande - Speziale Lochstempel auf Anfrage	pag.	11/12
Punzoni in metallo duro - Carbide punches - Poinçons en carbure - Lochstempel in hartmetall.	pag.	13
Spine cilindriche - Dowel pins - Goupilles cylindriques - Zylinderstifte DIN 6325	pag.	14
Spine cilindriche con foro filettato - Dowel pins with tapped hole - Goupilles cylindriques à trou taraudées - Zylinderstifte mit Innengewinde DIN 7979	pag.	15
Bussole di mascheraggio - Drill bushes - Bagues - Bohrbuchsen DIN 179	pag.	16
Bussole di mascheraggio - Drill bushes - Bagues - Bohrbuchsen DIN 172	pag.	17
Matrici per stampi - Dies - Matrices - Schneidbuchsen DIN 9485 FORMA A	pag.	18
Matrici per stampi - Dies - Matrices - Schneidbuchsen DIN 9485 FORMA B	pag.	19
Bussole di mascheraggio extralunghe - Drill bushes extra long size - Bagues extra longue - Bohrbuchsen extra lang DIN 179 - DIN 172	pag.	20
Bussole guida punzoni - Punch guide bushes - Bagues de guidage - Führungsbuchse DIN 9845 C	pag.	21
Matrici con preforo - Dies with start hole - Matrices - Schneidbuchsen ISO 8977 A - ISO 8977 B	pag.	22/23
Colonne tipo F.A. - Guide pillars F.A. - Colonnes de guidage F.A. - Säulen F.A.	pag.	24
Colonne tipo F.B. - Guide pillars F.B. - Colonnes de guidage F.B. - Säulen F.B.	pag.	25
Bussole guida Fig.A - Bushes A - Bagues A - Führungsbuchse A	pag.	26
Bussole guida Fig.A con scorrimento in bronzo - Bushes A with bronze - Bagues A avec bronze - Führungsbuchse A mit Bronze	pag.	27
Colonne estraibili - Removable precision pillars - Colonnes de guidage demontable - Präzisions Wechselsäule	pag.	28
Bussole in acciaio estraibili e con scorrimento in bronzo - Demountable steel and bronze bushes - Bagues demontable en acier et en bronze - Führungsbuchse aus Stahl und mit Bronze	pag.	29/33
Colonne guida stampi - Guide pins - Colonnes - Präzision Führungssäulen DIN 9825	pag.	34
Bussole con gabbia a sfere - Guide bushes with ball bearing sleeves - Bague de guidage avec cage à bille - Buchse mit Kugelhäufige R 92	pag.	35
Unità di guida a sfere - Unit guide with ball bearing sleeves - Unité de guidage avec cage à bille - Buchse mit Kugelhäufige R 93	pag.	36/37
Molle in acciaio - Die springs - Ressortes - Druckfedern ISO 10243	pag.	38/51

Barre tonde in poliuretano - Polyurethan springs - Ressortes en poliuretano - Poliuretano Federn	pag.	52
Barre tonde Retflex - Retflex springs - Ressortes Retflex - Retflex Federn	pag.	53/58
Viti a colletto - Shoulder screws - Vises epaulées - Paßschrauben ISO 7379	pag.	59
Viti a colletto con distanziale rettificato - Shoulder screws with ground spacer - Vises avec entretoise rectifiée - Schrauben mit Distanzrohr geschliffen	pag.	60
Pressori a molla - Screws pushers - Vises à bille à ressort - Federne Druckstücke.	pag.	61
Trascinatori - Parting locks - Elements de fixation - Fixage elemente.	pag.	62
Blocchi portastampo a 2 e 4 colonne - Die sets with 2 and 4 pillars - Blocs à colonnes avec 2 et 4 colonnes - Säulengestellt mit 2 und 4 Säulen	pag.	63/78
Estrattori testa svasata - Conical head ejectors - Éjecteurs tête conique - Auswerferstifte DIN 1530 D	pag.	79
Espulsori testa cilindrica temprati - Hardened ejector pins cyl. head - Éjecteurs tête cylindrique trempés - Auswerferstifte zyl. Kopf DIN ISO 6751 AH	pag.	80
Espulsori con testa cilindrica temprati - Hardened ejector pins cyl. head - Éjecteurs tête cylindrique trempés - Auswerferstifte zyl. Kopf gehärtet Tipo Fiat	pag.	81
Espulsori testa cilindrica nitrurati - Nitrided ejector pins cyl. head - Éjecteurs tête cylindrique nitrurés - Auswerferstifte zyl. Kopf DIN ISO 6751 A	pag.	82
Espulsori testa cilindrica nitrurati neri - Nitrided ejector pins form A black - Éjecteurs nitrurés forme A noire - Auswerferstifte mit zyl. Kopf nitriert Form A Schwarz DIN ISO 6751 A	pag.	83
Espulsori testa cilindrica nitrurati - Nitrided ejector pins cyl. head - Éjecteurs tête cylindrique nitrurés - Auswerferstifte zyl. Kopf TIPO FIAT	pag.	84
Espulsori non nitrurati lavorabili - Core pins - Ejecteurs broche - Kernstifte Unnitriert	pag.	85
Espulsori testa cilindrica temprati FORMA C. - Hardened ejector pins cyl. head Form C. - Éjecteurs tête cylindrique trempés Form C. - Auswerferstifte zyl. Kopf gehärtet Form C. DIN ISO 8694 CH	pag.	86
Espulsori con testa cilindrica nitrurati forma C - Nitrided ejector pins form C - Éjecteurs nitrurés form C - Auswerferstifte mit zyl. Kopf nitriert Form C DIN ISO 8694 C	pag.	87
Espulsori con testa cilindrica nitrurati neri forma C - Black nitrided ejector pins form C - Éjecteurs nitrurés noirs form C - Auswerferstifte mit zyl. Kopf nitriert schwarz Form C DIN 8694 C	pag.	88
Espulsori a lamella temprati - Blade ejectors hardened - Éjecteurs à lame trempés - Flauchauswerferstifte gehärtet DIN ISO 8693 FH	pag.	89
Espulsori con testa cilindrica nitrurati a lamella - Blade ejectors nitrided - Ejecteurs à lame nitrurés - Flachauswerferstifte nitriert DIN ISO 8693 F	pag.	90
Espulsori con testa cilindrica temprati a lamella con 4 raggi d'angolo 0,2 mm - Blade ejectors hardened with 4 corner radiuses 0,2 mm - Ejecteurs à lame trempés avec 4 radions angulaires 0,2 mm - Flachauswerferstifte gehärtet mit 4 eckenradien 0,2 mm DIN ISO 8693 FH	pag.	91
Bussole di espulsione temprate - Ejector Sleeves hardened - Éjecteurs tubulaires trempés - Auswerferhülsen gehärtet DIN ISO 8405	pag.	92
Bussole di espulsione nitrurate lucide - Ejector Sleeves nitrided polished - Ejecteurs tubulaires nitrurés polis - Auswerferhülsen nitriert blanks DIN ISO 8405	pag.	93
Colonne per stampi plastica - Guide pillars for plastic moulds - Colonne de guidage - Abstreiferführungssäulen TIPO 32 P	pag.	94
Colonne per stampi - Guide pillars - Colonne de guidage - Führungssäulen TIPO 33 PT	pag.	95-96
Colonne per stampi - Guide pillars - Colonne de guidage - Führungssäulen TIPO PTR	pag.	97
Bussole per stampi - Guide bushes - Bagues de guidage - Führungsbuchsen TIPO PA	pag.	98
Bussole con collare per stampi plastica - Headed guide bushes - Bagues à collarete - Führungsbuchsen mit Bund TIPO 38 PB	pag.	99

Bussole spallate - Shouldered bushes - Bagues de guidage epaulées - Führungsbuchsen mit Bund und Ansatz TIPO PR	pag.	100
Bussole guida stampi - Headed guide bushes - Bagues à collarette - Führungsbuchsen mit Bund TIPO PBR	pag.	101
Bussole d'iniezione - Sprue bushings - Buses d'injection - Angussbuchsen	pag.	102
Piedini appoggio tavolino - Stop pins - Butées de course d'ejection - Anschläge	pag.	102
Centraggi conici - Locating elements - Plots de centrage - Zentriereinheiten	pag.	103
Anelli di centraggio - Locating rings - Bagues de centrage - Zentrierscheiben.	pag.	103
Unità di centraggio - Centering elements - Plots de centrage - Zentriereinheiten	pag.	104
Centratori laterali - Side interlocks - Plots de centrage lateral - Zentriereinheit	pag.	105
Blocco di centraggio - Taper block - Blocs de centrage - Zentriereinheit.	pag.	106
Datari - Daters - Dateurs - Datumstempel TIPO KR	pag.	107
VKT Valvole per compensazione aria - Air valves - Soupapes de compensation d'air - Luftventile	pag.	108
VKT B Valvole di compensazione aria - Air valve - Soupape de compensation - Luftventile.	pag.	109
Marchi di riciclaggio - Recycling marks - Marques de recuperation - Recycling Stempel.	pag.	110
Valvole e raccordi rapidi - Water connectors - Couplers rapide - Schnellkupplung	pag.	111
Raccordi per stampi con esagono interno e esterno - Hose extension - Raccord mouliste - Kuhlanschluß Stücke	pag.	112
Tappi per circuiti di raffreddamento - Plugs O-ring seal - Bouchon avec anneau torique - Verschluss stopfen. ...	pag.	113
Dispositivo automatico d'estrazione - Automatic lifting-return device - Dispositif automatique d'extraction rappel - Automatische Auswerfer Rückzug Einrichtung.	pag.	114/121
Blocchi portastampi per materie plastiche - Standard mould bases - Carcasses pour moules - Standardformen	pag.	122/168
Piastre rettificate in acciaio indeformabile - Ground plates - Plaques rectifiées - Platten Geschliffen	pag.	169/170
Troncatrice serie DIAMANTE ARIA - Cut-off machine - Tronçonneuse - Trenn Maschine	pag.	171
Troncatrice serie DIAMANTE ABZ - Cut-off machine - Tronçonneuse - Trenn Maschine	pag.	172
Supporti antivibranti Vibrolevel - Antivibrations Vibrolevel	pag.	173
Supporti antivibranti Vibrotap - Antivibrations Vibrotap.	pag.	174
Tabella tolleranze - Tolerances tables - Tableau des tolerances - Abmaße Tabelle.	pag.	175

DIN 9861
Form DA - WS

Acciaio
Steel
Acier
Werkstoff

- w S = Acciaio al Cromo-Vanadio- Volframio
- w S = Special alloy steel
- w S = Acier Tungsténe Vanadium
- w S = Werkzeugstahl

Lunghezza
Length
Longueur
Länge

Lunghezza standard:
71 - 80 - 100 mm

Standard lengths:
71 - 80 - 100 mm

Longueurs normalisées:
71 - 80 - 100 mm

Länge:
71 - 80 - 100 mm

Durezza
Hardness
Dureté
Härte

Gambo: 60/62 HRC
Testa: 45±5 HRC

Shaft: 60/62 HRC
Head: 45±5 HRC

Corp: 60/62 HRC
Tête: 45±5 HRC

Schافت: 60/62 HRC
Kopf: 45±5 HRC

Esecuzione
Finish
Exécution
Ausführung

Rettificato - Lappato
 Ground - Lapped
 Rectifiés - Polis
 Geschliffen - Geläpft

Testa ricalcata a caldo
 The head is hot forged

A richiesta rivestimento TiN
 On request TiN
 Sur demande TiN
 Auf Anfrage TiN

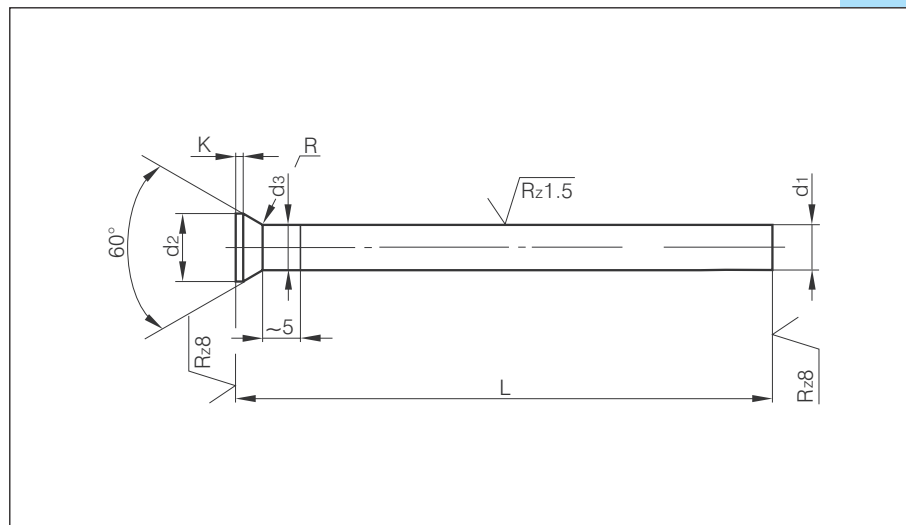

d1 h6	d2	d3 max	K +0,2	L + 0,5		
				71	80	100
0,5	0,9	d1+0,02	0,2			
0,6	1,1					
0,7	1,3					
0,8	1,4					
0,9	1,6	d1+0,03	0,4			
1,0/1,1	1,8					
1,2/1,3	2,0					
1,4/1,5	2,2					
1,6/1,7	2,5	d1+0,03	0,5			
1,8/1,9	2,8					
2,0	3,0					
2,1/2,2	3,2					
2,3/2,5	3,5	d1+0,03	0,5			
2,6/2,9	4,0					
3,0/3,4	4,5					
3,5/3,9	5,0					
4,0/4,4	5,5	d1+0,03	0,5			
4,5/4,9	6,0					
5,0/5,4	6,5					
5,5/5,9	7,0					
6,0/6,4	8,0	d1+0,03	0,5			
6,5/7,4	9,0					
7,5/8,4	10,0					
8,5/9,4	11,0					
9,5/10,4	12,0	d1+0,04	1,0			
10,5/11,4	13,0					
11,5/12,4	14,0					
12,5/13,4	15,0					
13,5/14,4	16,0	d1+0,04	1,0			
14,5/15	17,0					
15,1/16	18,0					
16,1/17	19,0					
17,1/18	20,0	d1+0,04	1,5			
18,1/19	21,0					
19,1/20	22,0					
20,1/21	23,0					
21,1/22	24,0	d1+0,04	1,5			

DIN 9861
Form D - HWS-HSS

Acciaio
Steel
Acier
Werkstoff

- Hw S** = Acciaio speciale al 12% di Cromo
- HSS** = Acciaio Super rapido
- Hw S** = 12% Chrome alloy steel
- HSS** = High speed steel
- Hw S** = Acier Spécial 12% Chrome
- HSS** = Acier rapid
- Hw S** = 12% Chromlegiert Stahl
- HSS** = Hochleistungs - Schnellstahl

Lunghezza
Length
Longueur
Länge

- Lunghezza standard:**
71 - 80 - 100 mm
- Standard lengths:**
71 - 80 - 100 mm
- Longueurs nominales:**
71 - 80 - 100 mm
- Länge:**
71 - 80 - 100 mm

Durezza
Hardness
Dureté
Härte

- Gamma:** HWS 60/62 HRC
- Testa:** HWS 45±5 HRC
- Gamma:** HSS 62/64 HRC
- Testa:** HSS 52±3 HRC
- Shaft:** HWS 60/62 HRC
- Head:** HWS 45±5 HRC
- Shaft:** HSS 62/64 HRC
- Head:** HSS 52±3 HRC
- Corp:** HWS 60/62 HRC
- Tête:** HWS 45±5 HRC
- Corp:** HSS 62/64 HRC
- Tête:** HSS 52±3 HRC
- Schaft:** HWS 60/62 HRC
- Kopf:** HWS 45±5 HRC
- Schaft:** HSS 62/64 HRC
- Kopf:** HSS 52±3 HRC

Esecuzione
Finish
Exécution
Ausführung

- Rettificato - Lappato
- Ground - Lapped
- Rectifiés - Polis
- Geschliffen - Geläpft
- Testa riscaldata a caldo
- The head is hot forged

A richiesta investire in T.N.
 On request T.N.
 Sur demande T.N.
 Auf Anfrage T.N.

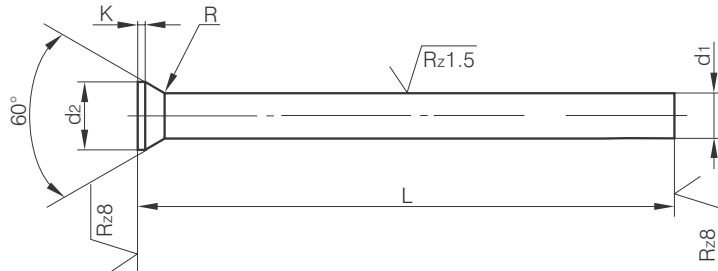

d1 h6	d2	K +0,2	L +0,5		
			71	80	100
0,5	0,9	0,2			
0,6	1,1				
0,7	1,3				
0,8	1,4	0,4			
0,9	1,6				
1,0/1,1	1,8	0,5			
1,2/1,3	2,0				
1,4/1,5	2,2				
1,6/1,7	2,5	0,5			
1,8/1,9	2,8				
2,0	3,0	0,5			
2,1/2,2	3,2				
2,3/2,5	3,5				
2,6/2,9	4,0	0,5			
3,0/3,4	4,5				
3,5/3,9	5,0	0,5			
4,0/4,4	5,5				
4,5/4,9	6,0				
5,0/5,4	6,5	0,5			
5,5/5,9	7,0				
6,0/6,4	8,0	1,0			
6,5/7,4	9,0				
7,5/8,4	10,0				
8,5/9,4	11,0	1,0			
9,5/10,4	12,0				
10,5/11,4	13,0	1,0			
11,5/12,4	14,0				
12,5/13,4	15,0				
13,5/14,4	16,0	1,5			
14,5/15	17,0				
15,1/16	18,0	1,5			
16,1/17	19,0				
17,1/18	20,0				
18,1/19	21,0	1,5			
19,1/20	22,0				
20,1/21	23,0	1,5			
21,1/22	24,0				

Punzoni di precisione
Round precision piercing punches
Poinçons de précision ronds
Präzisions Lochstempel

DIN 9861
Form D - ASP 2023

Acciaio
Steel
Acier
Werkstoff

ASP 2023

Lunghezza
Length
Longueur
Länge

Lunghezza standard:
 71 - 80 - 100 mm

Standard lengths:
 71 - 80 - 100 mm

Longueurs nominales:
 71 - 80 - 100 mm

Länge:
 71 - 80 - 100 mm

Durezza
Hardness
Dureté
Härte

Gamma: 62/66 HRC
Testa: 45±5 HRC

Shaft: 62/66 HRC
Head: 45±5 HRC

Corp: 62/66 HRC
Tête: 45±5 HRC

Schaft: 62/66 HRC
Kopf: 45±5 HRC

Esecuzione
Finish
Exécution
Ausführung

Rettificato - Lappato
 Ground - Lapped
 Rectifiés - Polis
 Geschliffen - Geläpft
 Testa riscaldata a caldo
 The head is hot forged

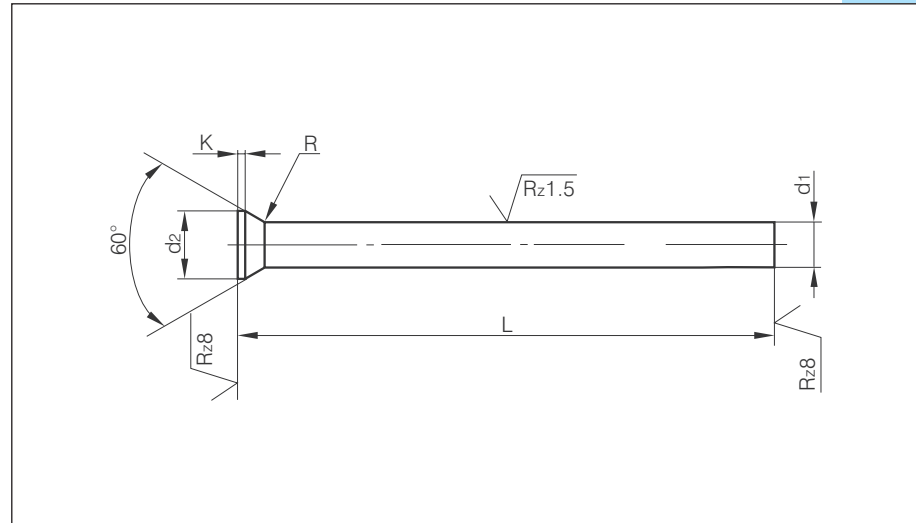

d1 h6	d2	K +0,2	L +0,5		
			71	80	100
0,5	0,9	0,2			
0,6	1,1				
0,7	1,3				
0,8	1,4	0,4			
0,9	1,6				
1,0/1,1	1,8				
1,2/1,3	2,0	0,5			
1,4/1,5	2,2				
1,6/1,7	2,5				
1,8/1,9	2,8	0,5			
2,0	3,0				
2,1/2,2	3,2				
2,3/2,5	3,5	0,5			
2,6/2,9	4,0				
3,0/3,4	4,5				
3,5/3,9	5,0	0,5			
4,0/4,4	5,5				
4,5/4,9	6,0				
5,0/5,4	6,5	0,5			
5,5/5,9	7,0				
6,0/6,4	8,0				
6,5/7,4	9,0	1,0			
7,5/8,4	10,0				
8,5/9,4	11,0				
9,5/10,0	12,0	1,0			
10,5/11,0	13,0				
11,5/12,0	14,0				
12,5/13,0	15,0	1,5			
13,5/14,0	16,0				
14,5/15,0	17,0				
15,5/16,0	18,0				

A richiesta rivestimento TN
 On request TN
 Sur demande TN
 Auf Anfrage TN

Punzoni di precisione
Round precision piercing punches
Poinçons de précision ronds
Präzisions Lochstempel

DIN 9861
Form D - HSS

Acciaio
Steel
Acier
Werkstoff

HSS = Acciaio Super rapido

HSS = High speed steel

HSS = Acier rapid

HSS = Hochleistungs -
Schnellstahl

Lunghezza
Length
Longueur
Länge

Lunghezze standard:
130 - 160 - 200 mm

Standard lengths:
130 - 160 - 200 mm

Longueurs normalisées:
130 - 160 - 200 mm

Länge:
130 - 160 - 200 mm

Durezza
Hardness
Durété
Härte

Gamma: 62/64 HRC
Testa: 52±3 HRC

Shaft: 62/64 HRC
Head: 52±3 HRC

Corp: 62/64 HRC
Tête: 52±3 HRC

Schافت: 62/64 HRC
Kopf: 52±3 HRC

Esecuzione
Finish
Exécution
Ausführung

Rettificato - Lappato
Ground - Lapped
Rectifiés - Polis
Geschliffen - Geläpft

Testa ricalcata a caldo
The head is hot forged

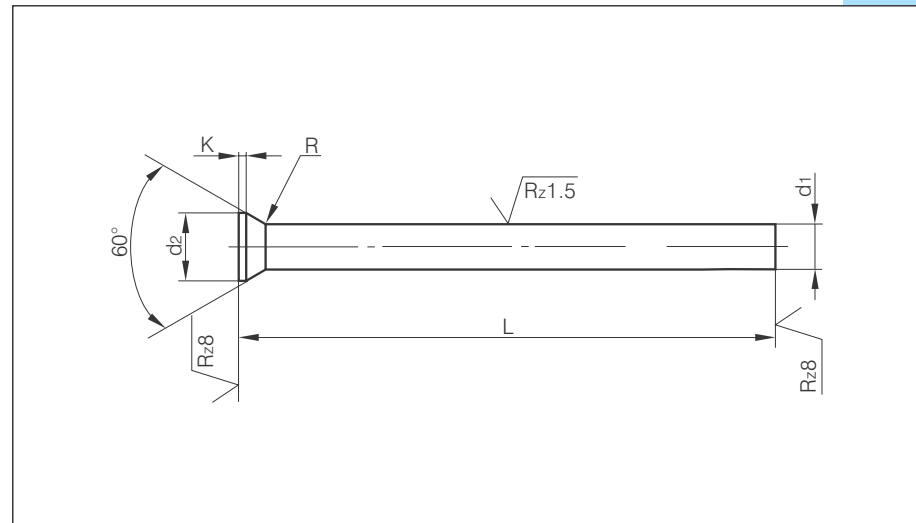

d1 h6	d2	K +0,2	L +0,5		
			130	160	200
2,0	3,0	0,5			
2,1/2,2	3,2	0,5			
2,3/2,5	3,5				
2,6/2,9	4,0	0,5			
3,0/3,4	4,5				
3,5/3,9	5,0				
4,0/4,4	5,5	0,5			
4,5/4,9	6,0				
5,0/5,4	6,5	0,5			
5,5/5,9	7,0				
6,0/6,4	8,0				
6,5/7,4	9,0	1,0			
7,5/8,4	10,0				
8,5/9,4	11,0	1,0			
9,5/10,0	12,0				
10,5/11,0	13,0				
11,5/12,0	14,0	1,5			
12,5/13,0	15,0				
13,5/14,0	16,0	1,5			
14,5/15	17,0				
15,5/16	18,0				
16,5/17	19,0	1,5			
17,5/18	20,0				
18,5/19	21,0				
19,5/20	22,0				

A richiesta rivestimento TiN
 On request TiN
 Sur demande TiN
 Auf Anfrage TiN

**DIN 986 I
Form D - HSS**

**Acciaio
Steel
Acier
Werkstoff**

HSS

**Lunghezza
Length
Longueur
Länge**

Lunghezza standard:
40 - 60 - 70 - 80 - 90 - 100 - 120

Standard lengths:
40 - 60 - 70 - 80 - 90 - 100 - 120

Longueurs normalisées:
40 - 60 - 70 - 80 - 90 - 100 - 120

Länge:
40 - 60 - 70 - 80 - 90 - 100 - 120

**Durezza costante
Constant Hardness
Dureté constante
Durchgehend Gehärtet**

64 +2 HRC

**Esecuzione
Finish
Exécution
Ausführung**

Rettificato
Ground
Rectifiés
Geschliffen

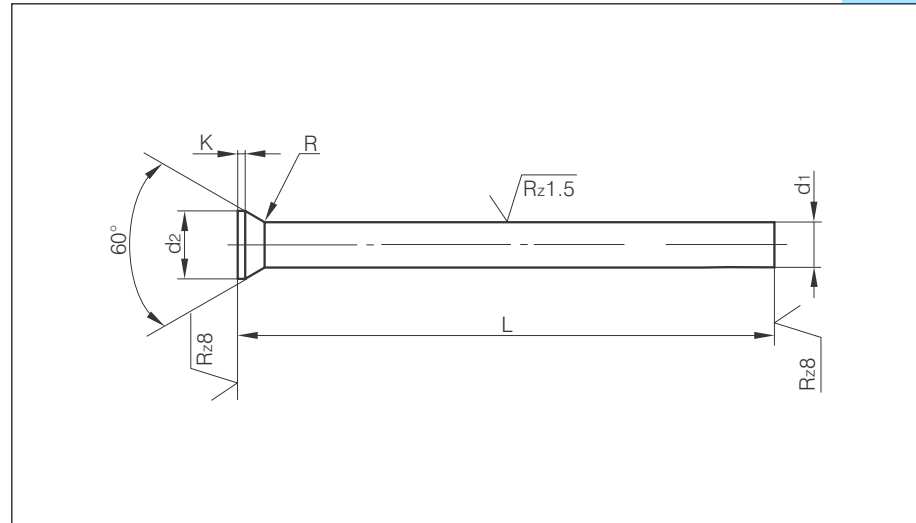

d1 h6	d2	K +0,2	L +0,5							
			40	60	70	80	90	100	120	
1,0/1,1	1,8	0,5								
1,2/1,3	2,0									
1,4/1,5	2,2									
1,6/1,7	2,5	0,5								
1,8/1,9	2,8									
2,0	3,0									
2,1/2,2	3,2	0,5								
2,3/2,5	3,5									
2,6/2,9	4,0									
3,0/3,4	4,5	0,5								
3,5/3,9	5,0									
4,0/4,4	5,5									
4,5/4,9	6,0	0,5								
5,0/5,4	6,5									
5,5/5,9	7,0									
6,0/6,4	8,0	1,0								
6,5/7,4	9,0									
7,5/8,4	10,0									
8,5/9,4	11,0	1,0								
9,5/10,0	12,0									
10,5/11,0	13,0									
11,5/12,0	14,0	1,0								
12,5/13,0	15,0									

Solo a richiesta
Only on request
Seulement sur demande
Nur auf Anfrage

Acciaio
Steel
Acier
Werkstoff

W S

Durezza gambo: 60/62 HRC
Shaft hardness: 60/62 HRC
Durezza corp: 60/62 HRC
Härte Schaft: 60/62 HRC

Testa: 45±5 HRC
Head: 45±5 HRC
Tête: 45±5 HRC
Kopf: 45±5 HRC

Esecuzione
Finish
Exécution
Ausführung

Rettificato - Lappato
Ground - Lapped
Rectifiés - Polis
Geschliffen - Geläpft

Testa riscalcata a caldo
The head is hot forged

Altre misure, materiali ed
esecuzioni a richiesta

Other dimensions, materials
and executions on request

Autres dimensions, matériaux
et formes sur demande

Acciaio
Steel
Acier
Werkstoff

H W S
HSS

Durezza gambo: HWS 60/62
HSS 62/64 HRC
Shaft hardness: HWS 60/62
HSS 62/64 HRC
Durezza corp: HWS 60/62
HSS 62/64 HRC
Härte Schaft: HWS 60/62
HSS 62/64 HRC

Testa: HWS 45±5
HSS 52±3 HRC
Head: HWS 45±5
HSS 52±3 HRC
Tête: HWS 45±5
HSS 52±3 HRC
Kopf: HWS 45±5
HSS 52±3 HRC

Esecuzione
Finish
Exécution
Ausführung

Rettificato - Lappato
Ground - Lapped
Rectifiés - Polis
Geschliffen - Geläpft

Testa riscalcata a caldo
The head is hot forged

Altre misure, materiali ed
esecuzioni a richiesta

Other dimensions, materials
and executions on request

Autres dimensions, matériaux
et formes sur demande

A richiesta investimento
On request T N
Sur demande T N
Auf Anfrage T N

Punzoni di precisione forma CA
Round precision piercing punches form CA
Poinçons de precision forme CA
Präzisions Lochstempel Form CA

DIN 9861
Form CA

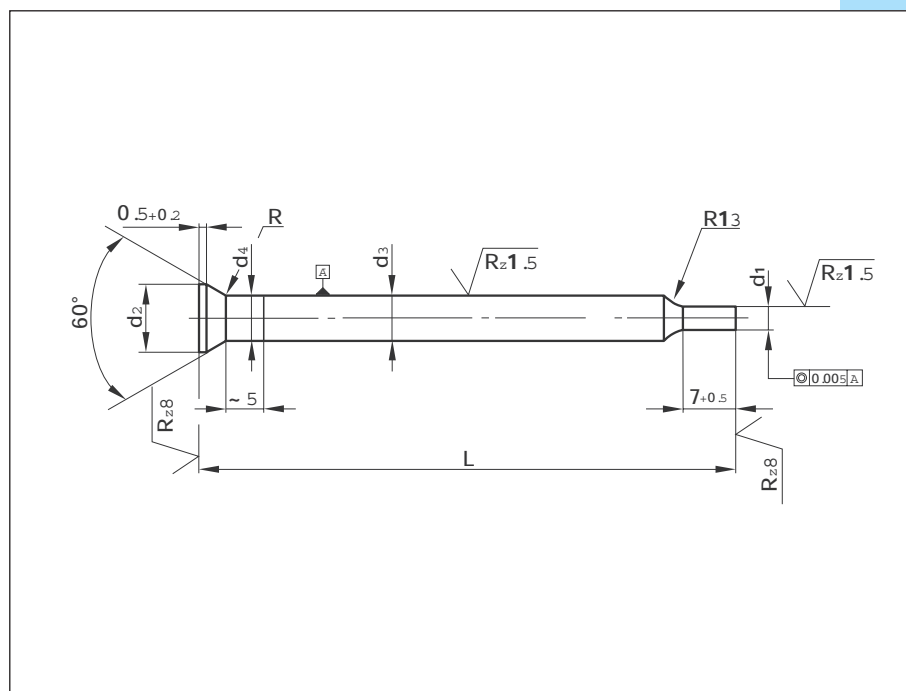

d1 h6	d2	d3 h6	L+0,5
0,5 - 1,5	3,0	2,0	71/80/100
1,55 - 2,95	4,5	3,0	71/80/100

Punzoni di precisione forma C
Round precision piercing punches form C
Poinçons de precision forme C
Präzisions Lochstempel Form C

DIN 9861
Form C

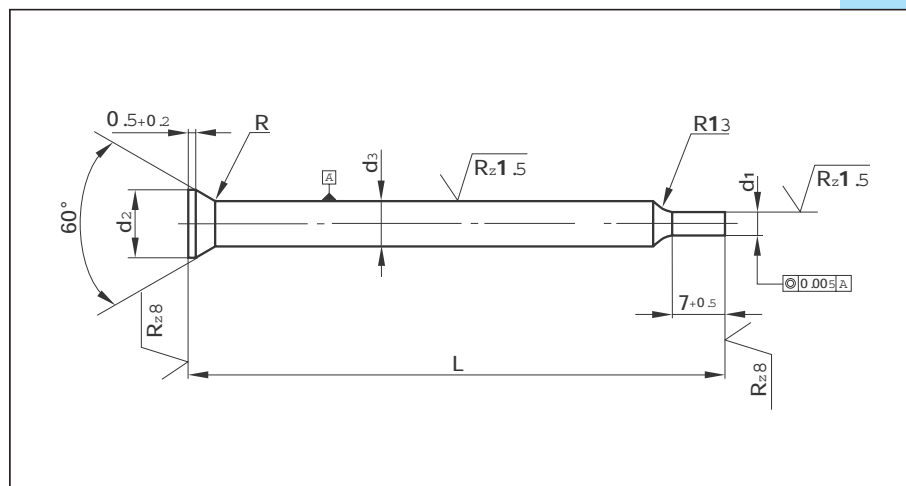

d1 h6	d2	d3 h6	d4 max	L+0,5
0,5 - 1,5	3,0	2,0	d1 + 0,03	71/80/100
1,55 - 2,95	4,5	3,0	d1 + 0,03	71/80/100

Punzoni con testa cilindrica
Round precision punches with cylindrical head
Poinçons ronds avec tête cylindrique
Präzisions Lochstempel mit zyl. Kopf

ISO 8020

Acciaio
Steel
Acier
Werkstoff

HW S
 HSS

Durezza
Hardness
Dureté
Härte

Gamma **HW S** = 60-62

Testa: 45±5 HRC

Head: 45±5 HRC

Tête: 45±5 HRC

Kopf: 45±5 HRC

Gamma **HSS** = 62-64 HRC

Testa: 52±3 HRC

Head: 52±3 HRC

Tête: 52±3 HRC

Kopf: 52±3 HRC

Esecuzione
Finish
Exécution
Ausführung

Rettificato - Lappato
 Ground - Lapped
 Rectifiés - Polis
 Geschliffen - Geläpft

Testa riscaldata a caldo
 The head is hot forged

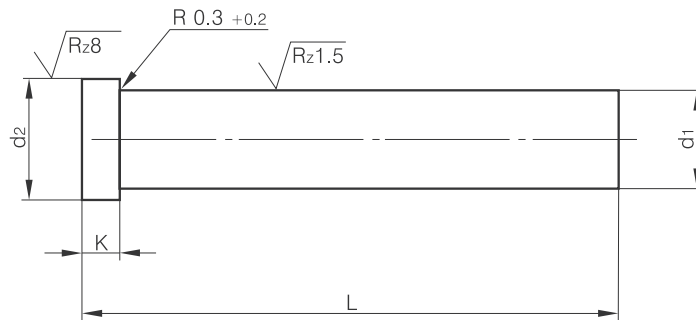

d1 m 5	d2 0/-0,15	K +0,1/+0,2	L+0,5		
			71	80	100
3	5	3			
4	6	3			
5	8	5			
6	9	5			
8	11	5			
10	13	5			
13	16	5			
16	19	5			
20	23	5			
25	28	5			
32	35	5			

Ø 3 a richiesta
 Ø 3 on request
 Ø 3 sur demande
 Ø 3 auf Anfrage

A richiesta rivestimento TiN
 On request TiN
 Sur demande TiN
 Auf Anfrage TiN

Acciaio
Steel
Acier
Werkstoff

H_W S
 HSS

Durezza
Hardness
Dureté
Härte

Gam **bo H_W S** = 60-62 HRC

Testa: 45±5 HRC

Head: 45±5 HRC

Tête: 45±5 HRC

Kopf: 45±5 HRC

Gam **bo HSS** = 62-64 HRC

Testa: 52±3 HRC

Head: 52±3 HRC

Tête: 52±3 HRC

Kopf: 52±3 HRC

Esecuzione
Finish
Exécution
Ausführung

Rettificato - Lappato
 Ground - Lapped
 Rectifiés - Polés
 Geschliffen - Geläpft

Testa riscaldata a caldo
 The head is hot forged

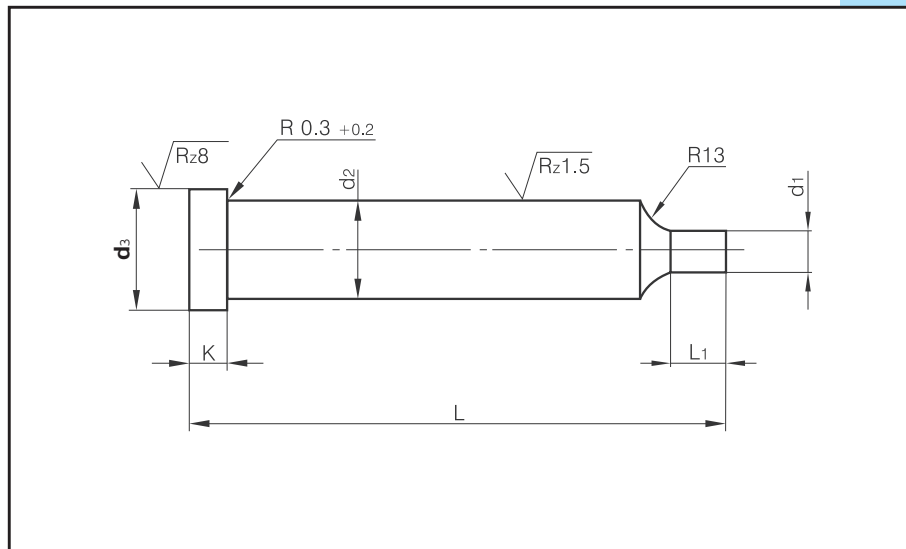

d2 m 5	d3 -0,15	K +0,1/+0,2	L1 +0,5	d1 +0,01	L +0,5		
					71	80	100
3	5	3	10	0,8 - 2,9			
4	6	3	10	2 - 3,9			
5	8	5	10	2 - 4,9			
6	9	5	10	3 - 5,9			
8	11	5	13	3 - 7,9			
10	13	5	17	4,5 - 9,9			
13	16	5	17	6,5 - 12,9			
16	19	5	17	9,5 - 15,9			
20	23	5	17	12,5 - 19,9			
25	28	5	17	16,5 - 24,9			

Ø 32 a richiesta
 Ø 32 On request
 Ø 32 sur demande
 Ø 32 auf Anfrage

A richiesta rivestimento TiN
 On request TiN
 Sur demande TiN
 Auf Anfrage TiN

**Punzoni con testa cilindrica forati
con estrattore e molla**
Punches cyl. head with ejector pin
Poinçons à tête cylindrique à éjecteur central
Schneidstempel mit Abstoßer

ISO 8020

Acciaio
Steel
Acier
Werkstoff

HSS

Durezza
Hardness
Dureté
Härte

Gam bo HSS: 62/64 HRC

Shaft HSS: 62/64 HRC

Corp HSS: 62/64 HRC

Schaft HSS: 62/64 HRC

Testa HSS: 52±3 HRC

Head HSS: 52±3 HRC

Tête HSS: 52±3 HRC

Kopf HSS: 52±3 HRC

Esecuzione
Finish
Exécution
Ausführung

Rettificato - Lappato
 Ground - Lapped
 Rectifiés - Polis
 Geschliffen - Geläpft

Testa riscaldata a caldo
 The head is hot forged

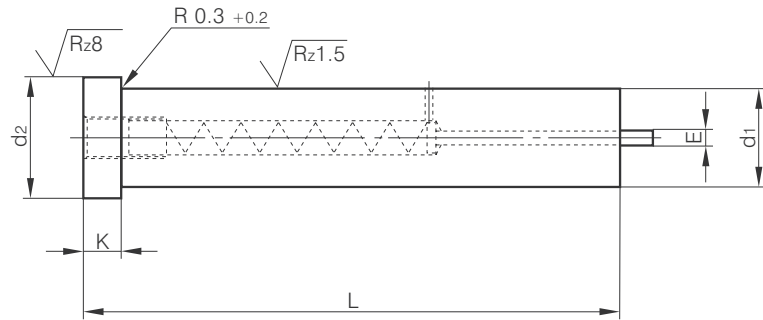

d1 m 5	d2 +0/-0,15	K +0/+0,2	E	L+0,5			
				63	71	80	100
6	9	5	1,0				
8	11	5	1,0				
10	13	5	1,4				
13	16	5	1,4				
16	19	5	2,1				
20	23	5	2,1				
25	28	5	2,1				
32	35	5	2,1				

A richiesta rivestimento TiN
 On request TiN
 Sur demande TiN
 Auf Anfrage TiN

**Punzoni con testa cilindrica forati
con estrattore e molla forma C**
Punches cyl. head with ejector pin form C
Poinçons à tête cylindrique à éjecteur central forme C
Schneidstempel mit Abstoßer Form C

ISO 8020

**Acciaio
Steel
Acier
Werkstoff**

HSS

**Durezza
Hardness
Dureté
Härte**

Gamma **HSS**: 62/64 HRC

Shaft **HSS**: 62/64 HRC

Corp **HSS**: 62/64 HRC

Schaft **HSS**: 62/64 HRC

Testa **HSS**: 52±3 HRC

Head **HSS**: 52±3 HRC

Tête **HSS**: 52±3 HRC

Kopf **HSS**: 52±3 HRC

**Esecuzione
Finish
Exécution
Ausführung**

Rettificato - Lappato
Ground - Lapped
Rectifiés - Polis

Geschliffen - Geläpft

Testa riscaldata a caldo
The head is hot forged

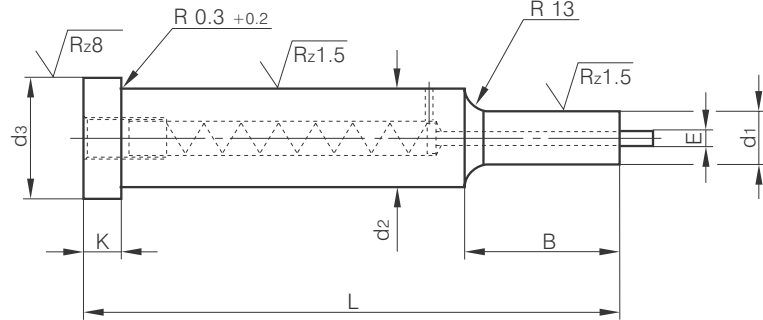

d2 m 5	d3 +0/-0,15	d1 -0,00/+0,01	K +0,1/+0,2	E	B		L +0,5			
					Standard	Max	63	71	80	100
6	9	2,5 - 5,9	5	1,0	13	25				
8	11	3,0 - 7,9	5	1,0	14	32				
10	13	4,0 - 9,9	5	1,4	16	32				
13	16	5,0 - 12,9	5	1,4	21	32				
16	19	8,0 - 15,9	5	2,1	24	32				
20	23	12,0 - 19,9	5	2,1	27	32				
25	28	17,0 - 24,9	5	2,1	32	32				
32	35	20 - 31,9	5	2,1	32	32				

A richiesta rivestimento **TiN**
 On request **TiN**
 Sur demande **TiN**
 Auf Anfrage **TiN**

Punzoni sagomati a richiesta
Punches as per drawing on request
Poinçons selon plan sur demande
Speziale Lochstempel auf Anfrage

BM
Industrie

Acciai WS/HWS/HSS/ASP23/ASP30

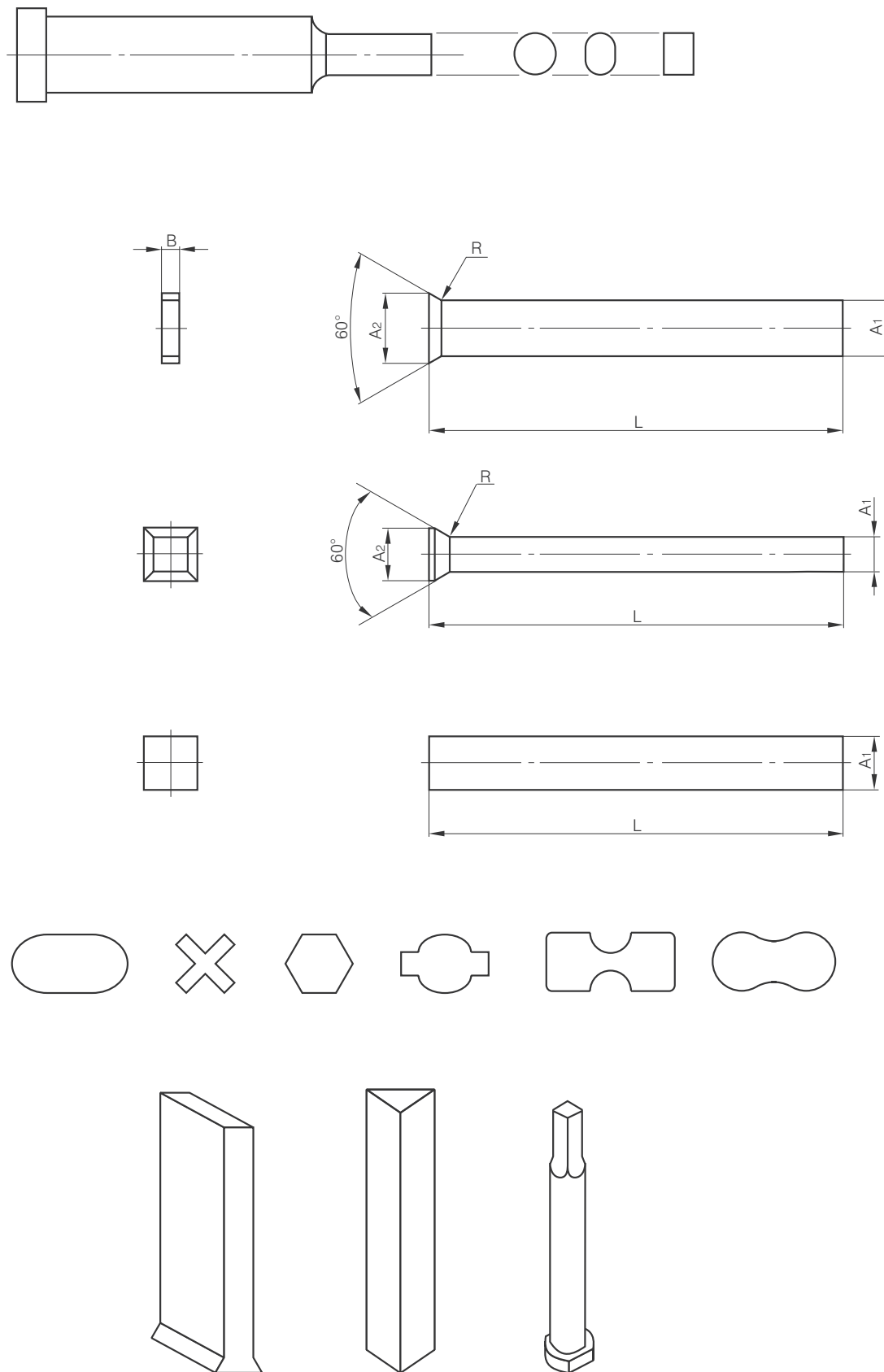

Punzoni sagomati a richiesta
Punches as drawing on request
Poinçons speciales sur demande
Spezielle Lochstempel auf Anfrage



Punzoni DIN 9861 / ISO8020
FORMA D-C / ISO8020 FORMA C
Punzoni speciali a disegno in metallo duro
Punches DIN 9861 / ISO8020
FORM D-C / ISO8020 FORM C
Special punches as drawing in carbide
Poinçons DIN 9861 / ISO8020
FORME D-C / ISO8020 FORME C
Poinçons speciaux selon plan en carbure
Lochstempel DIN 9861 / ISO8020
FORM D-C / ISO8020 FORM C
Lochstempel nach zeichnung in hartmetall

BM
Industrie

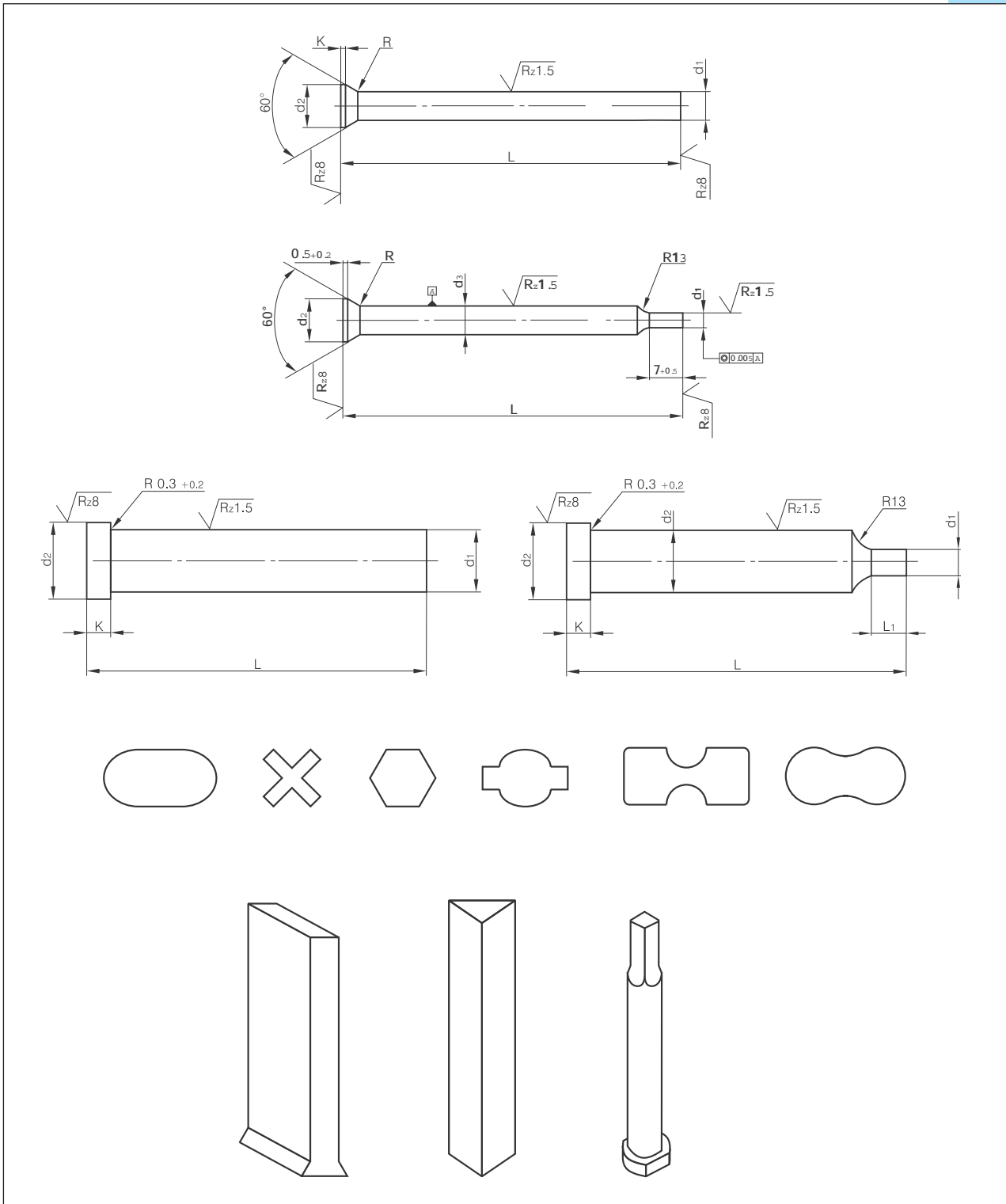

Spine cilindriche di precisione
Precision dowel pins
Goupilles cylindriques de precision
Präzisions Zylinderstifte

DIN 6325

Tolleranza: m . 6 - h. 6

Acciaio
Steel
Acier
Werkstoff

Acciaio per utensili
 Tool steel
 Acier pour outils
 Werkzeugstahl

Durezza
Hardness
Dureté
Härte

60±2 HRC

Esecuzione
Finish
Exécution
Ausführung

Temprate, rinvenute, rettificate,
 lucidate

Hardened, annealed, precision
 ground and lapped

Trempées, revenues et
 finement rectifiées

Gehärtet, angelassen,
 geschliffen und geläppt

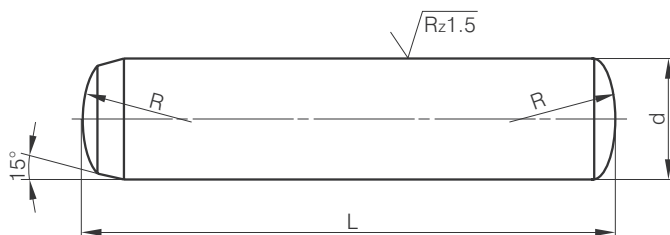

L \ d	1	1,5	2	2,5	3	4	5	6	8	10	12	14	16	18	20
10															
12															
14															
16															
18															
20															
24															
28															
30															
32															
36															
40															
45															
50															
55															
60															
70															
80															
90															
100															
120															
130															
140															
150															
160															

A richiesta Ø 2,5-13-25-30
 On request Ø 2,5-13-25-30
 Sur demande Ø 2,5-13-25-30
 Auf Anfrage Ø 2,5-13-25-30

Spine cilindriche con foro filettato
Precision dowel pins with tapped hole
Goupilles à trou taraudé
Präzisions Zylinderstifte mit Innengewinde

DIN 7979

Tolleranza: m . 6 - h. 6

Acciaio
Steel
Acier
Werkstoff

Acciaio per utensili
 Tool steel
 Acier pour outils
 Werkzeugstahl

Durezza
Hardness
Dureté
Härte

60±2 HRC

Esecuzione
Finish
Exécution
Ausführung

Temprate, rinvenute, rettificate, lucidate

Hardened, annealed, precision ground and lapped

Trempées, revenues et finement rectifiées

Gehärtet, angelassen, geschliffen und geläpft

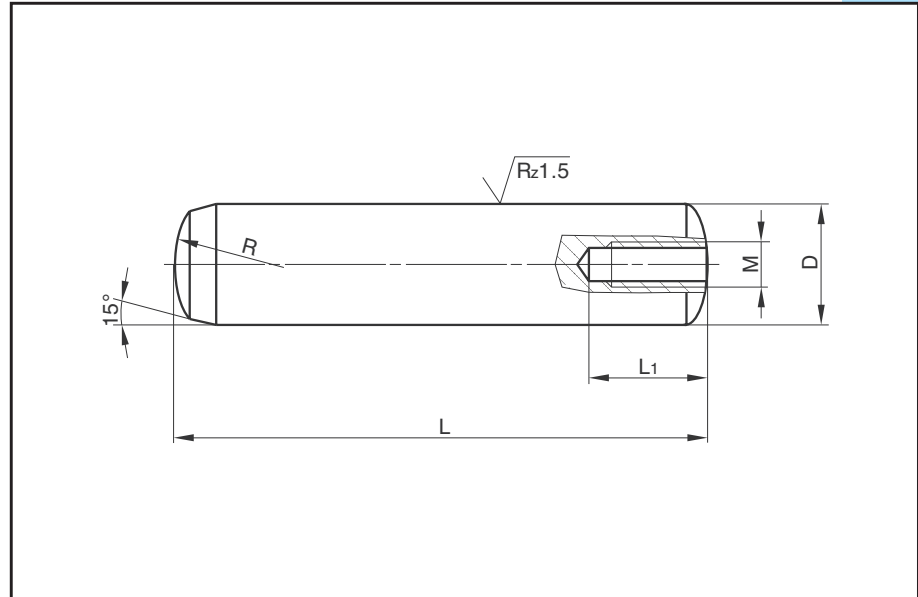

L1	10	10	12	16	16	20	20	22	25	30	36	48
L \ D	5x3 MA	6x4 MA	8x5 MA	10x6 MA	12x6 MA	14x8 MA	16x8 MA	18x10 MA	20x10 MA	25x16 MA	30x20 MA	40x20 MA
16												
20												
24												
28												
30												
32												
36												
40												
45												
50												
55												
60												
70												
80												
90												
100												
120												
130												
140												
150												
160												
170												
180												
190												
200												

Acciaio
Steel
Acier
Werkstoff

88 MN V8

Durezza
Hardness
Dureté
Härte

60-62 HRC

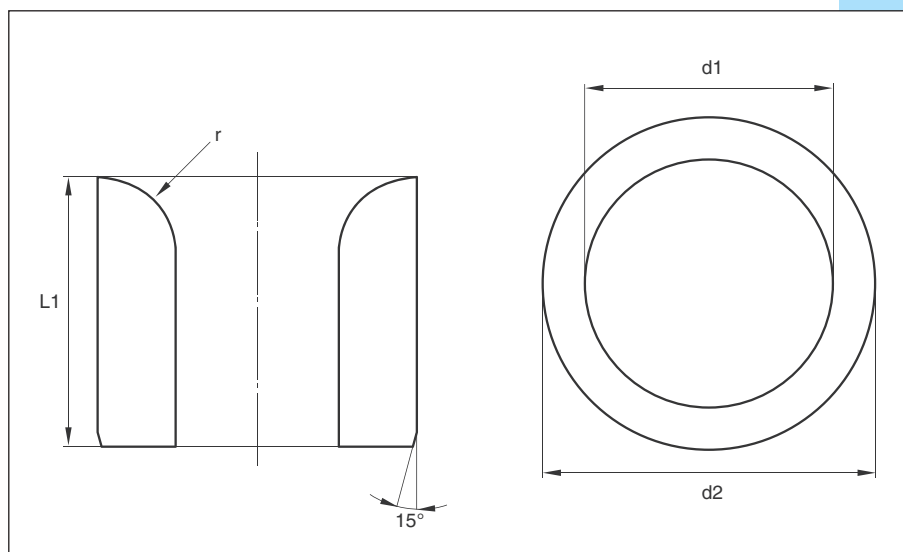
Esecuzione
Finish
Exécution
Ausführung
Temprate, rinvenute, rettificate,
lucidateHardened, annealed, precision
ground and lappedTrepées, revenues et
finement rectifiéesGehärtet, angelassen,
geschliffen und geläpft

d1 F7	PROGRESSIONE	d2 n6	L1 CORTA	L1 LUNGA
0,9 - 1,0	0,1	3	6	9
1,1 - 1,8	0,1	4	6	9
1,9 - 2,6	0,1 - 0,25	5	6	9
2,7 - 3,3	0,1 - 0,25	6	8	12
3,4 - 4,0	0,1 - 0,25	7	8	12
4,1 - 5,0	0,1 - 0,25	8	8	12
5,1 - 6,0	0,1 - 0,25	10	10	16
6,1 - 8,0	0,1 - 0,25	12	10	16
8,1 - 10	0,1 - 0,25	15	12	20
10,1 - 12	0,1 - 0,25	18	12	20
12,1 - 15	0,1 - 0,25	22	16	28
15,25 - 18	0,25	26	16	28
18,25 - 22	0,25	30	20	36
22,25 - 26	0,25	35	20	36
26,25 - 30	0,25	42	20/25	36/45
30,25 - 35	0,25	48	25	45
35,5 - 42	0,5	55	25/30	45/56
42,5 - 48	0,5	62	30	56
48,5 - 55	0,5	70	30	56
56 - 63	1,0	78	35	67/72

Diametri superiori a richiesta
Bigger diameters on request

Acciaio
Steel
Acier
Werkstoff

88 MN V8

Durezza
Hardness
Durété
Härte

60-62 HRC

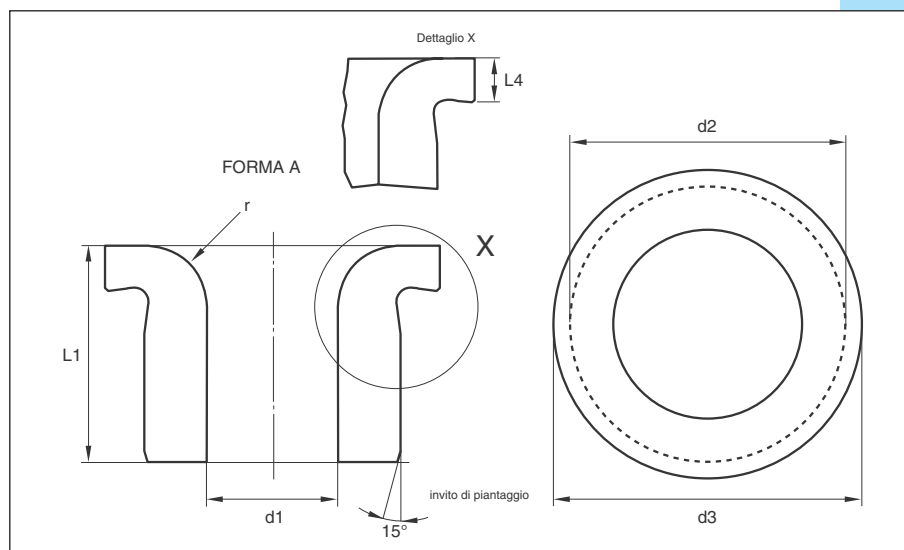
Esecuzione
Finish
Exécution
Ausführung
Temprate, rinvenute, rettificate,
lucidateHardened, annealed, precision
ground and lappedTrepées, revenues et
finement rectifiéesGehärtet, angelassen,
geschliffen und geläpft

d1 F7	PROGRESSIONE	d2 n6	d3	Corte		Lunghe	
				L1	L4	L1	L4
0,9 - 1,0	0,1	3	6	6	2	9	2
1,1 - 1,8	0,1	4	7	6	2	9	2
1,9 - 2,6	0,1 - 0,25	5	8	6	2	9	2
2,7 - 3,3	0,1 - 0,25	6	9	8	2*/2,5	12	2,5
3,4 - 4,0	0,1 - 0,25	7	10	8	2,5	12	2,5
4,1 - 5,0	0,1 - 0,25	8	11	8	2,5	12	2,5
5,1 - 6,0	0,1 - 0,25	10	13	10	3	16	3
6,1 - 8,0	0,1 - 0,25	12	15	10	3	16	3
8,1 - 10	0,1 - 0,25	15	18	12	3	20	3
10,1 - 12	0,1 - 0,25	18	22	12	4	20	4
12,1 - 15	0,1 - 0,25	22	26	16	4	28	4
15,25 - 18	0,25	26	30	16	4	28	4
18,25 - 22	0,25	30	34	20	5	36	5
22,25 - 26	0,25	35	39	20	5	36	5
26,25 - 30	0,25	42	46	20/25	5	36/45	5
30,25 - 35	0,25	48	52	25	5	45	5
35,5 - 42	0,5	55	59	25/30	5	45/56	5
42,5 - 48	0,5	62	66	30	6	56	6
48,5 - 55	0,5	70	74	30	6	56	6
56 - 63	1,0	78	82	35	6	67/72	6

Diametri superiori a richiesta
Bigger diameters on request

**DIN 9845
Form A**

**Acciaio
Steel
Acier
Werkstoff**

UX 200 C13
HSS 1.3343

**Durezza
Hardness
Dureté
Härte**

60-62 HRC

**Esecuzione
Finish
Exécution
Ausführung**

Temprate, rinvenute, rettificate,
lucidate

Hardened, annealed, precision
ground and lapped

Trempées, revenues et
finement rectifiées

Gehärtet, angelassen,
geschliffen und geläpft

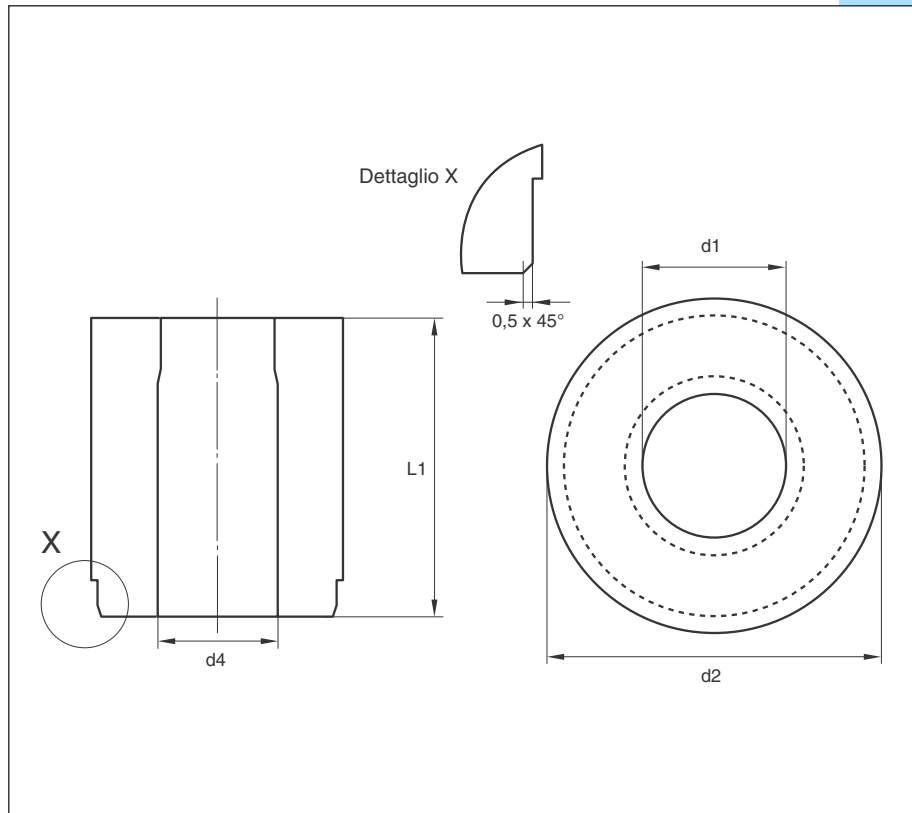

d1 H8	PROGRESSIONE	d2 n6	d4	L1 20	L1 28
0,8 - 1,0	0,1	5	d1 + 0,3		
1,1 - 2,0	0,1	6	d1 + 0,3		
2,1 - 3,3	0,1	7	d1 + 0,5		
3,4 - 4,0	0,1	8	d1 + 0,5		
4,1 - 5,0	0,1	10	d1 + 0,7		
5,1 - 6,0	0,1	12	d1 + 0,7		
6,1 - 8,0	0,1	15	d1 + 0,7		
8,1 - 10	0,1	18	d1 + 1,0		
10,1 - 12	0,1	22	d1 + 1,0		
12,1 - 15	0,1	26	d1 + 1,0		
15,5 - 18	0,5	30	d1 + 1,0		
18,5 - 22	0,5	35	d1 + 1,0		
22,5 - 26	0,5	42	d1 + 1,0		
26,5 - 30	0,5	48	d2 + 2,0		

Diametri superiori a richiesta
Bigger diameters on request

**Matrici
Dies
Matrices
Schneidbuchsen**

**BM
Industrie**

**DIN 9845
Form B**

**Acciaio
Steel
Acier
Werkstoff**

UX 200 C13
HSS 1,3343

**Durezza
Hardness
Dureté
Härte**

60-62 HRC

**Esecuzione
Finish
Exécution
Ausführung**

Temprate, rinvenute, rettificate,
lucidate

Hardened, annealed, precision
ground and lapped

Trempées, revenues et
finement rectifiées

Gehärtet, angelassen,
geschliffen und geläpft

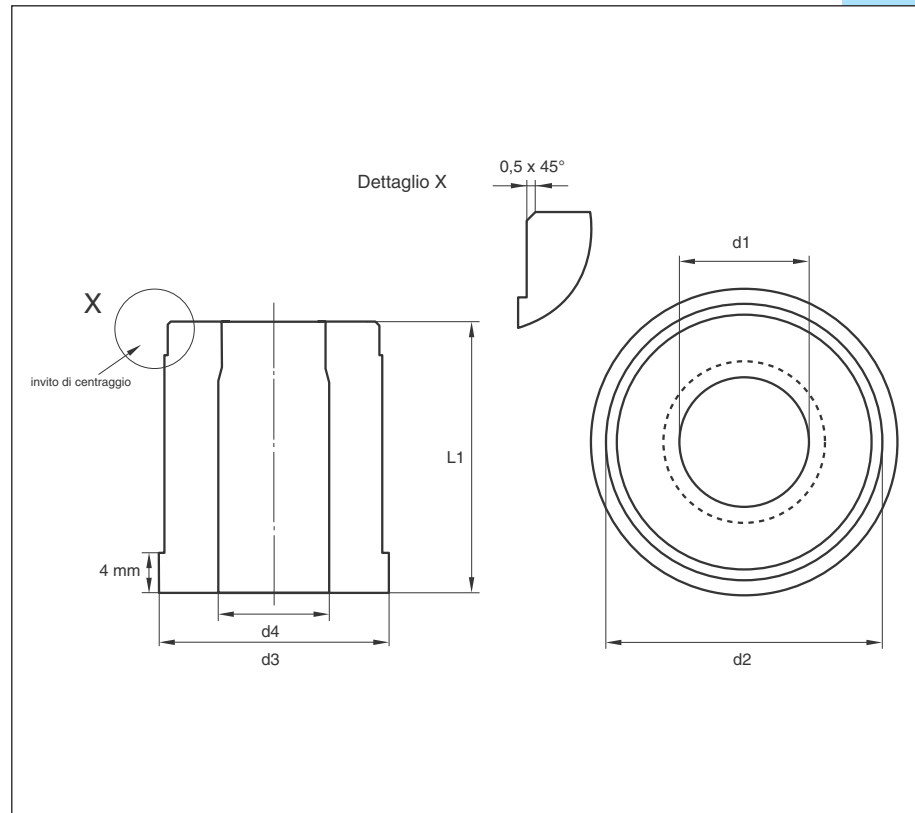

d1 H8	PROGRESSIONE	d2 n6	d3	d4	L1 20	L1 28
0,8 - 1,0	0,1	5	7	d1 + 0,3		
1,1 - 2,0	0,1	6	8	d1 + 0,3		
2,0 - 3,3	0,1	7	9	d1 + 0,5		
3,1 - 4,0	0,1	8	10	d1 + 0,5		
4,1 - 5,0	0,1	10	12	d1 + 0,7		
5,1 - 6,0	0,1	12	14	d1 + 0,7		
6,1 - 8,0	0,1	15	17	d1 + 0,7		
8,1 - 10	0,1	18	20	d1 + 1,0		
10,1 - 12	0,1	22	24	d1 + 1,0		
12,1 - 15	0,1	26	28	d1 + 1,0		
15,5 - 18	0,5	30	32	d1 + 1,0		
18,5 - 22	0,5	35	37	d1 + 1,0		
22,5 - 26	0,5	42	44	d1 + 1,0		
26,5 - 30	0,5	48	50	d2 + 2,0		

**Diametri superiori a richiesta
Bigger diameters on request**

Bussole extralunghe
Drill bushes extra long size
Bagues extra longue
Bohrbuchsen extra lang

BM Industrie

DIN 179
DIN 172

Acciaio
Steel
Acier
Werkstoff

16 Cr Ni 4

Durezza
Hardness
Dureté
Härte

60±2 HRC

Esecuzione
Finish
Exécution
Ausführung

Cementate, temperate

Cementing, hardening

Tolleranza
 Foro F7 - Diam. esterno n6

Tolerances of grinding
 Hole in F7 - outside in n6

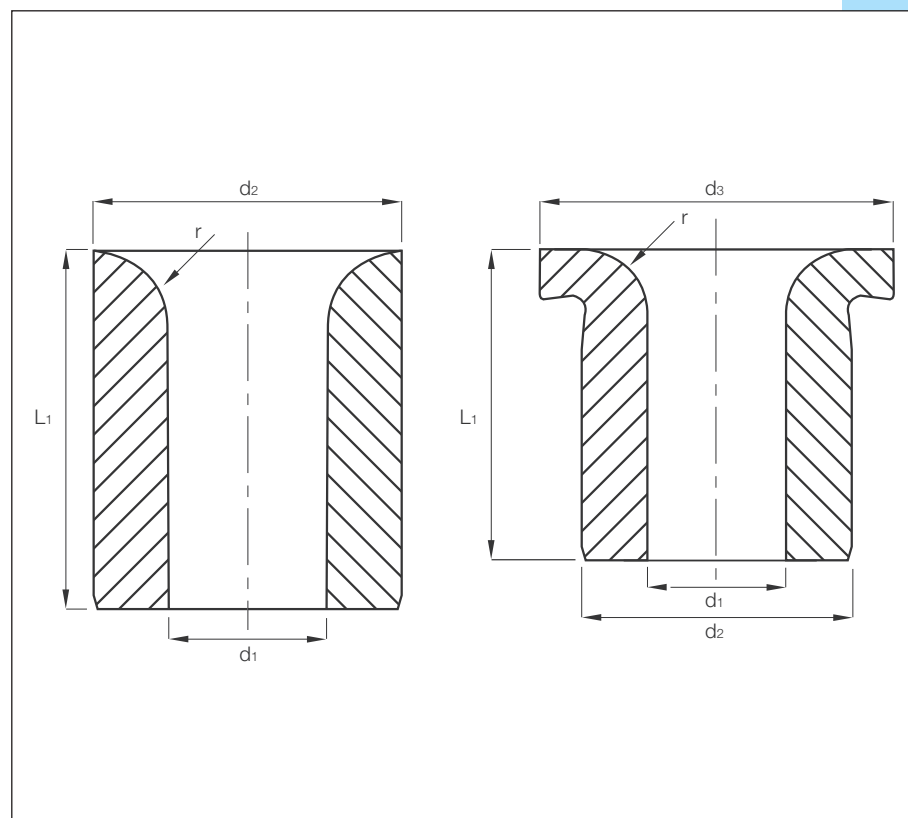

Ø d1	Ø d2	Ø d3	L1	DIN 179	DIN 172
2,7 - 2,75 - 3,0 - 3,25	6	9	16		
3,4 - 3,5 - 3,75 - 4,0	7	10	16		
4,1 - 4,25 - 4,5 - 4,75 - 5,0	8	11	16		
5,1 - 5,25 - 5,5 - 5,75 - 6,0	10	13	20		
6,1 - 6,25 - 6,5 - 6,75 - 7,0 7,25 - 7,5 - 7,75 - 8,0	12	15	20		
8,1 - 8,25 - 8,5 - 8,75 - 9,0 9,25 - 9,5 - 9,75 - 10,0	15	18	25		
10,1 - 10,5 - 11 - 11,5 - 12	18	22	25		
12,1 - 12,5 - 13 - 13,5 14,0 - 14,5 - 15,0	22	26	36		
15,25 - 15,5 - 16 - 16,5 17,0 - 17,5 - 18,0	26	30	36		

Bussole guida punzoni
Punch guide bushes
Bagues de guidage pour poingous
Führungsbuchse

BM
Industrie

DIN 9845 C

Acciaio
Steel
Acier
Werkstoff

HWS

Durezza
Hardness
Dureté
Härte

60±2 HRC

Esecuzione
Finish
Exécution
Ausführung

Temprate, rinvenute,
 Hardened, annealed

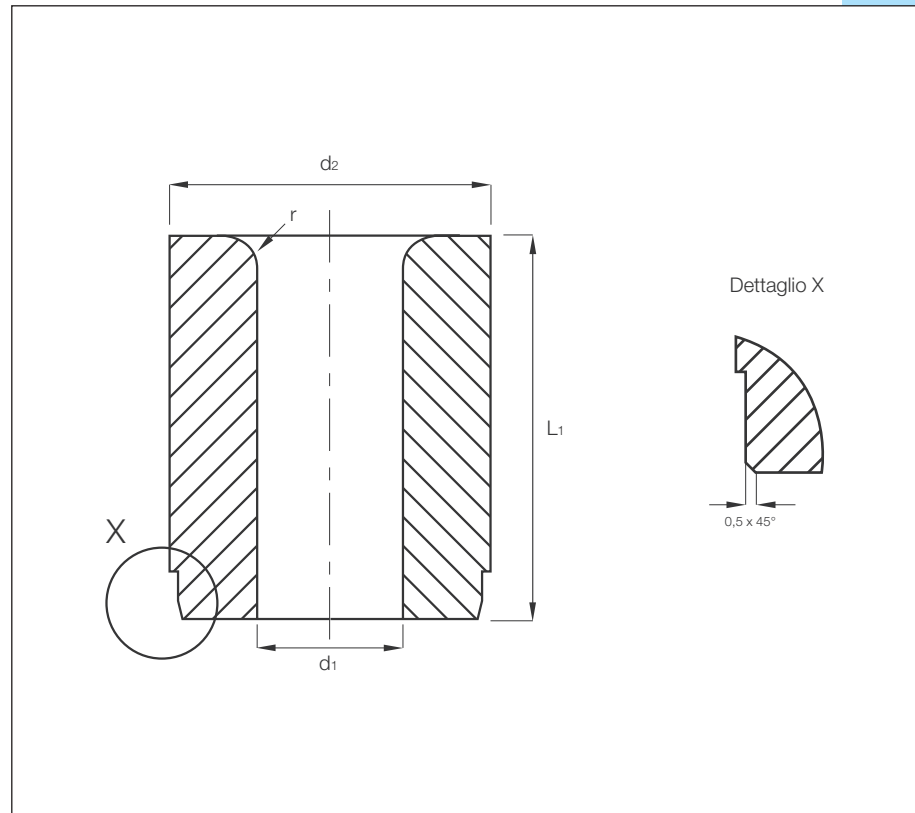

Ø d1 H7	PROGRESS ONE Advancem ent	Ø d2 n6	L1	
2,1 - 3,0	0,1	7	12	
3,1 - 4,0	0,1	8	12	
4,1 - 5,0	0,1	10	16	
5,1 - 6,0	0,1	12	16	
6,1 - 8,0	0,1	15	20	
8,1 - 10,0	0,1	18	20	
10,1 - 12,0	0,1	22	28	
12,1 - 15,0	0,1	26	28	
15,5 - 18,0	0,5	30	36	

Matrici con preforo
Dies with start hole
Matrices
Schneidbuchsen

BM
Industrie

ISO 8977 A

Acciaio
Steel
Acier
Werkstoff

HSS

Durezza
Hardness
Durété
Härte

63-64 HRC

Esecuzione
Finish
Exécution
Ausführung

Tempra sottovuoto

Vacuum Hardening

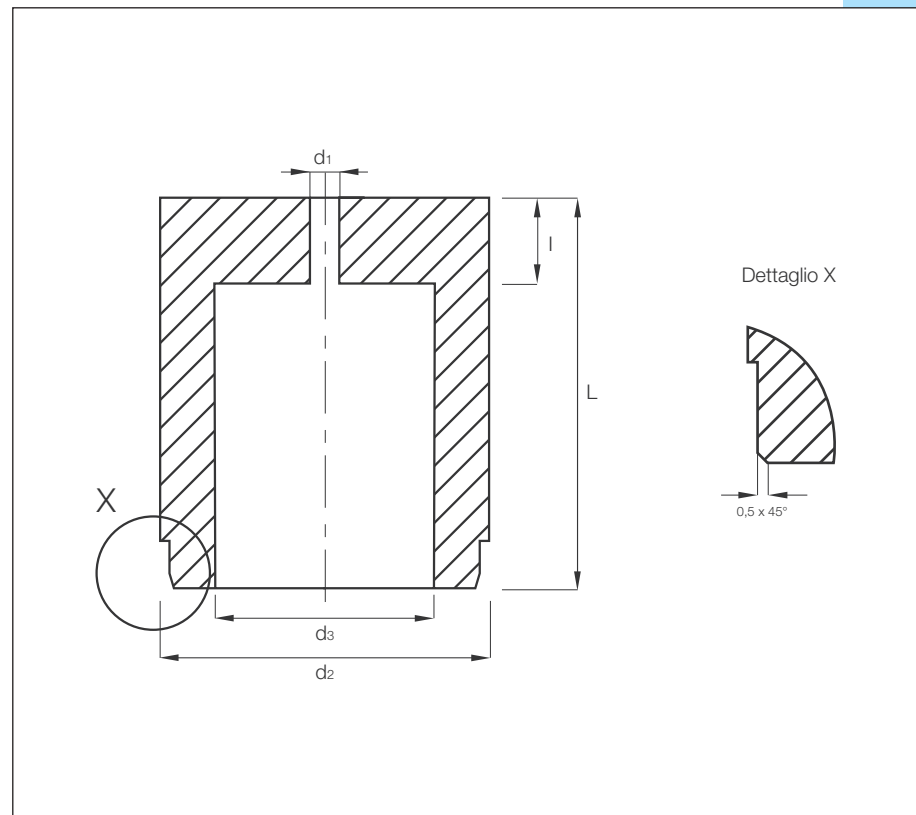

d_2 n5	d_1	16	L +0 / +0,5			d_3	l
			20	25	32		
5	1,0				-	2,8	2,0
6	1,0				-	3,5	3,0
8	1,0					4,0	4,0
10	1,0					5,8	4,0
13	1,2	-				8,0	5,0
16	1,2	-				9,5	5,0
20	1,5	-				12	8,0
25	1,5	-				17,3	8,0
32	1,5	-				20,7	8,0
40	1,5	-				27,7	8,0

Acciaio
Steel
Acier
Werkstoff

HSS

Durezza
Hardness
Dureté
Härte

63-64 HRC

Esecuzione
Finish
Exécution
Ausführung

Tempra sottovuoto

Vacuum Hardening

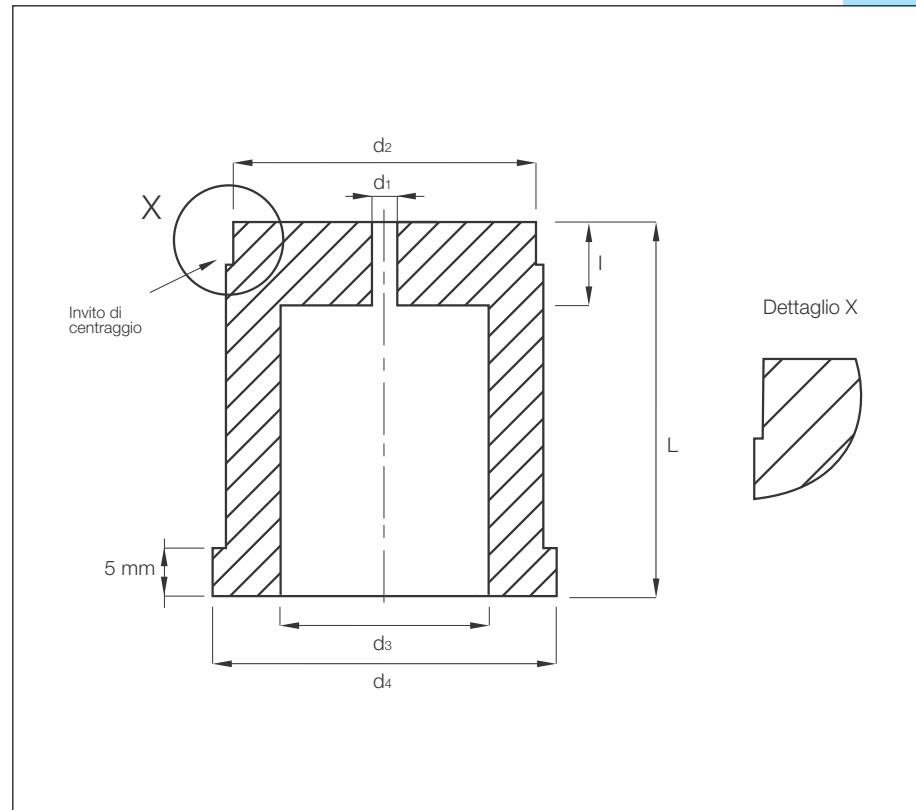

d_2 m 5	d_1	16	L +0 / +0,5			d_4	d_3	I
			20	25	32			
5	1,0				-	8	2,8	2
6	1,0				-	9	3,5	3
8	1,0					11	4,0	4
10	1,0					13	5,8	4
13	1,2	-				16	8,0	5
16	1,2	-				19	9,5	5
20	1,5	-				24	12,0	8
25	1,5	-				29	17,3	8
32	1,5	-				36	20,7	8
40	1,5	-				44	27,7	8

Colonne guida
Precision guide pillars
Colonne de guidage
Präzisions Führungssäulen

BM
Industrie

Tipo F.A.

Acciaio
Steel
Acier
Werkstoff

1.7131

Durezza
Hardness
Dureté
Härte

60-62 HRC

Esecuzione
Finish
Exécution
Ausführung

Cementate - temprate -
 rinvenute - rettificate

Case hardened - hardened
 throughout - annealed and
 ground

Trempés - cementés - revenus
 et rectifiées

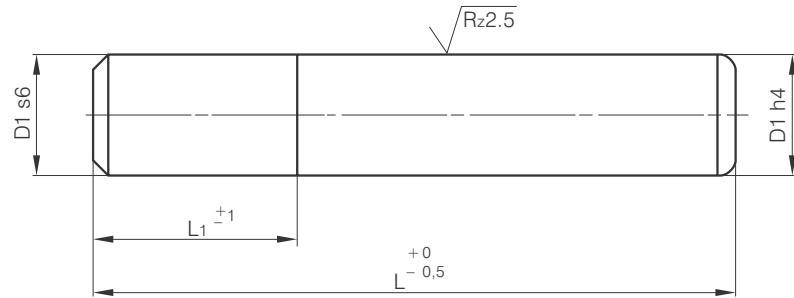

D1	L1	L																	
		85	95	105	115	125	135	145	155	170	185	200	225	250	275	300	325	350	400
15-16	16																		
	18																		
17-18	18																		
	20																		
19-20	20																		
	25																		
24-25	25																		
	30																		
30-31	30																		
	40																		
40-41	40																		
	50																		
50-51	50																		
63	63																		

Tipo F.B.

Acciaio
Steel
Acier
Werkstoff

1.7131

Durezza
Hardness
Dureté
Härte

60-62 HRC

Esecuzione
Finish
Exécution
Ausführung

Cementate - temprate -
 rinvenute - rettificata

Case hardened - hardened
 throughout - annealed and
 ground

Trempés - cementés - revenus
 et rectifiées

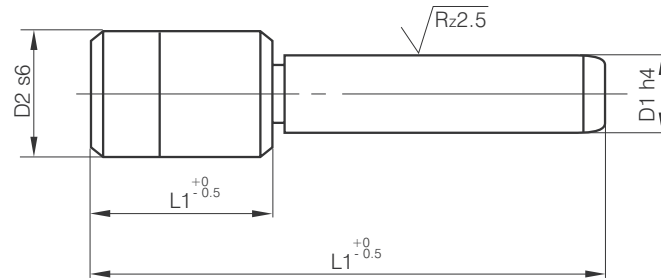

D1	D2	L1	L																	
			85	95	105	115	125	135	145	155	170	185	200	225	250	275	300	325	350	400
15-16	26	30																		
		30																		
17-18	28	30																		
		35																		
19-20	30	30																		
		35																		
24-25	36	35																		
		40																		
30-31	45	40																		
		45																		
40-41	55	60																		
		70																		
50-51	70	70																		

Bussole guida
Precision bushings fixed type
Bagues de guidage de precision type fixe
Präzisions Führungsbuchse

BM
Industrie

Tipo - Type A

Acciaio
Steel
Acier
Werkstoff

1.7131

Durezza
Hardness
Dureté
Härte

60-62 HRC

Esecuzione
Finish
Exécution
Ausführung

Cementate - temprate -
 rinvenute - rettificata

Case hardened - hardened
 throughout - annealed and
 ground

Trempés - cementés - revenus
 et rectifiées

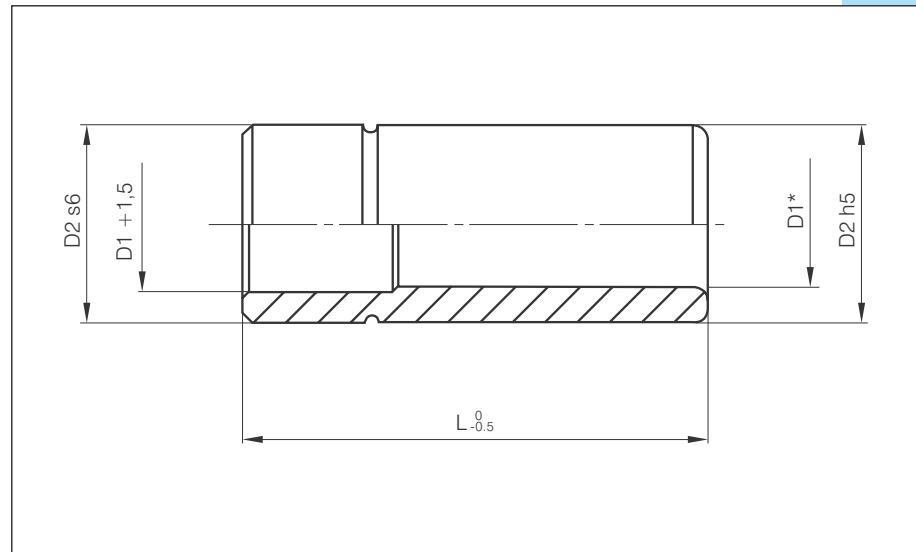

D1*	D1	D2	Serie normale L	Serie corta L	
+0,006	15 - 16	26	50	35	
	17 - 18	28	55	45	
	19 - 20	30	60	45	
	24 - 25	36	70	50	
+0,008	30 - 31	45	80	55	
	40 - 41	55	100	60	
	+0,012	50 - 51	70	100	60
		63	85	100	/

* A richiesta

Alte dimensioni a richiesta

Other dimensions on request

Autres dimensions sur demande

Bussole guida con scorrimento in bronzo
Precision bushings fixed type with bronze sleeve
Bagues de guidage de precision
type fixe avec bronze rapporté
Präzisions Führungsbuchse mit Bronze Auflage

Tipo - Type A

Acciaio
Steel
Acier
Werkstoff

1.7131

Durezza
Hardness
Dureté
Härte

60-62 HRC

Esecuzione
Finish
Exécution
Ausführung

Cementate - temprate -
 rinvenute - rettificata

Case hardened - hardened
 throughout - annealed and
 ground

Trempés - cementés - revenus
 et rectifiées

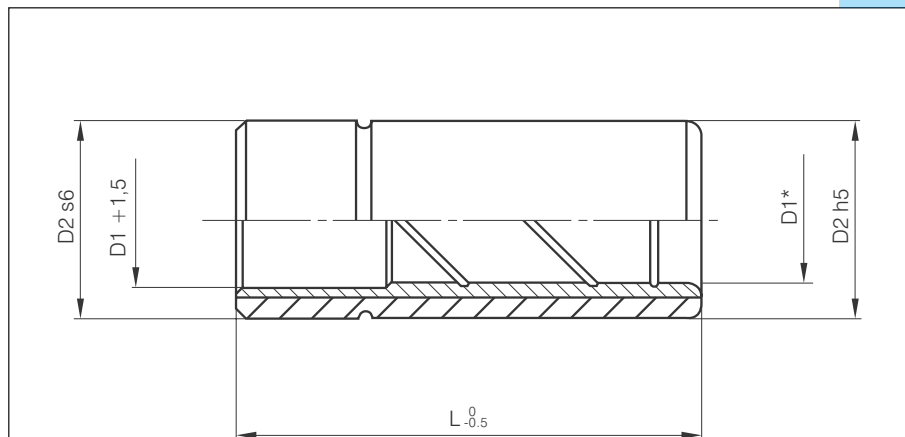

D1*	D1	D2	Serie normale L	Serie corta L	
+0,006	15 - 16	26	50	35	
	17 - 18	28	55	45	
	19 - 20	30	60	45	
	24 - 25	36	70	50	
+0,008	30 - 31	45	80	55	
	40 - 41	55	100	60	
	+0,012	50 - 51	70	100	60
		63	85	100	/

Altre dimensioni richiesta
 Other dimensions on request
 Autres dimensions sur demande

Colonne estraibili
Removable precision guide pillars
Colonnes de guidage
de precision type demontable
Präzisions - Wechselsäule

BM
Industrie

Acciaio
Steel
Acier
Werkstoff

1,7131

Durezza
Hardness
Dureté
Härte

60-62 HRC

Esecuzione
Finish
Exécution
Ausführung

Cementate - temprate -
 rinvenute - rettificate

Case hardened - hardened
 throughout - annealed and
 ground

Trempés - cementés - revenus
 et rectifiées

- Staffette e viti a richiesta
 - Clamps and screws
 on request

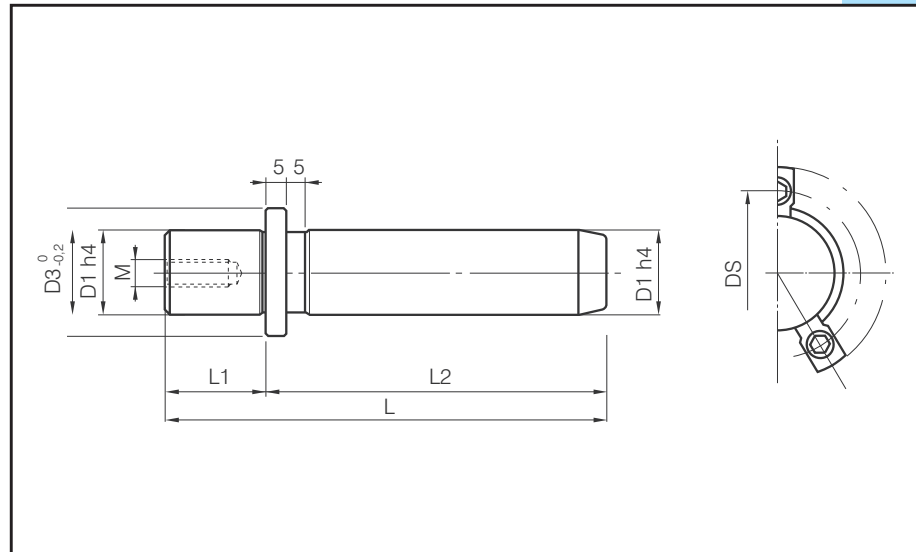

D1	D3	M	DS	STAFF	L1
18/19	25	8	33	M6	20
24/25	32	10	40	M6	25
30/32	40	10	50	M8	30
40/42	50	12	60	M8	35
50/52	62	12	72	M8	45
63	73	12	83	M8	49
63	77	12	87	M8	49

Diam e tra	Lunghezza L2																		
	100	110	120	130	140	150	160	170	180	200	220	240	260	280	300	320	360	400	
18/19																			
24/25																			
30/32																			
40/42																			
50/52																			
63																			
63																			

- A richiesta
- On request
- Sur demande
- Auf Anfrage

Bussole in acciaio estraibili
Bussole con scorrimento in bronzo estraibili
Demountable Steel bushes - Demountable bushes with bronze
Bagues demontable en acier - Bagues demontable avec bronze
Führungsbuchse - Führungsbuchse mit Bronze Auflage



SIGLE PER BRONZO - BRONZE

BSBS - BSBL - BNBS - BLBS - BLXS

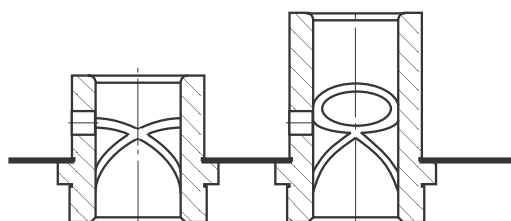

•BSBS
•BSBSA

•BSBL
•BSBLA

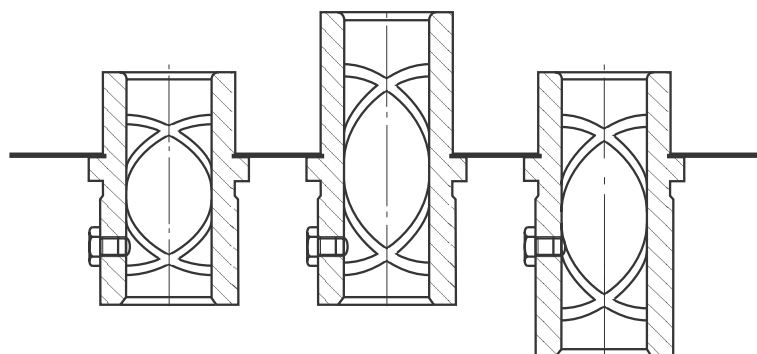

•BNBS
•BNBSA

•BLBS
•BLBSA

•BLXS
•BLXSA

SIGLE PER ACCIAIO - STEEL - ACIER - STAHL

● BSBSA ● BSBLA ● BNBSA ● BLBSA ● BLXSA

- PRONTE A MAGAZZINO
- READY IN STOCK
- PRÊT AU MAGASIN
- AM LAGER

Acciaio
Steel
Acier
Werkstoff

1.7131

Durezza
Hardness
Durété
Härte

60-62 HRC

Esecuzione
Finish
Exécution
Ausführung

Cementate - temprate -
 rinvenute - rettificata

Case hardened - hardened
 throughout - annealed and
 ground

Trempés - cementés - revenus
 et rectifiés

- Sede di montaggio h6
 - Ogni bussola deve essere
 fissata con 2 o 3 staffette e viti
 a seconda la dimensione

- Staffette e viti a richiesta
 - Clamps and screws
 on request

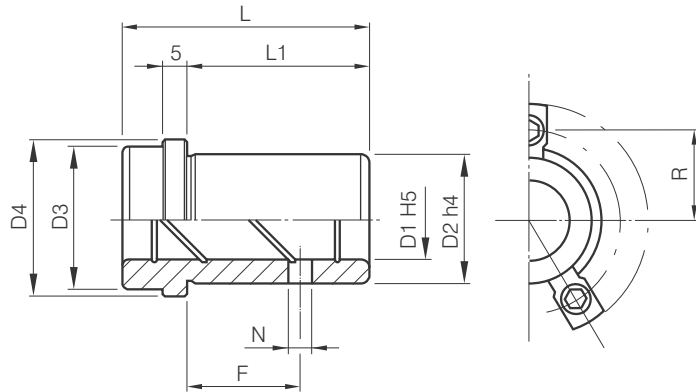

Tipo	B S B S A									B S B L A							
	D1	L	D2	D3	D4	L1	R	N	F	L	D2	D3	D4	L1	R	N	F
18/19	31	28	29	34	18	21	5	8	8	50	28	29	34	37	21	5	8
24/25	36	38	39	44	23	26	5	9	9	55	38	39	44	42	26	5	12
30/32	43	45	48	53	30	31,5	5	11	11	60	45	48	53	47	31,5	5	16
40/42	51	54	58	63	38	36,5	8	11	11	67	54	58	63	54	36,5	8	19
50/52	61	65	74	79	48	44,5	8	14	14	75	65	74	79	62	44,5	8	19
63	74	81	87	92	61	51	8	19	19	90	81	87	92	77	51	8	19

- A richiesta
- On request
- Sur demande
- Auf Anfrage

Bussole estraibili in acciaio
Demountable steel bushes
Bagues demontable en acier
Stahl Führungsbuchse

Acciaio
Steel
Acier
Werkstoff

1.7131

Durezza
Hardness
Dureté
Härte

60-62 HRC

Esecuzione
Finish
Exécution
Ausführung

Cementate - temprate -
 rinvenute - rettificata

Case hardened - hardened
 throughout - annealed and
 ground

Trempés - cementés - revenus
 et rectifiés

- Sede di montaggio h6
 - Ogni bussola deve essere
 fissata con 2 o 3 staffette e viti
 a seconda la dimensione

- Staffette e viti a richiesta
 - Clamps and screws
 on request

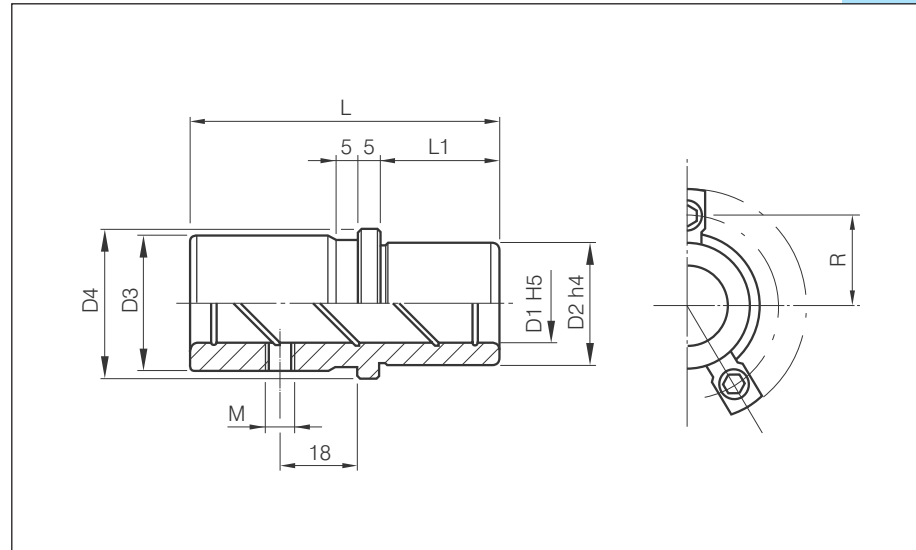

Tipo	BNB SA								BLXSA								BLB SA							
	D1	L	D2	D3	D4	L1	R	M	L	D2	D3	D4	L1	R	M	L	D2	D3	D4	L1	R	M		
18/19	50	28	31	34	18	21	6X1	70	28	31	34	18	21	6X1	70	28	31	34	27	21	6X1			
24/25	55	38	41	44	23	26	10X1	80	38	41	44	23	26	10X1	80	38	41	44	32	26	10X1			
30/32	60	45	50	53	26	31,5	10X1	90	45	50	53	26	31,5	10X1	90	45	50	53	37	31,5	10X1			
40/42	67	54	60	63	30	36,5	10X1	100	54	60	63	30	36,5	10X1	100	54	60	63	47	36,5	10X1			
50/52	75	65	76	79	35	44,5	10X1	110	65	76	79	35	44,5	10X1	110	65	76	79	57	44,5	10X1			
63	90	81	89	92	48	51	10X1	130	81	89	92	48	51	10X1	130	81	89	92	67	51	10X1			

- A richiesta
- On request
- Sur demande
- Auf Anfrage

**Bussole estraibili
con scorrimento in bronzo**
Demountable bushes with bronze
Bagues demontable avec bronze
Führungsbuchse mit Bronze Auflage

**Acciaio
Steel
Acier
Werkstoff**

1.7131

**Durezza
Hardness
Dureté
Härte**

60-62 HRC

**Esecuzione
Finish
Exécution
Ausführung**

Cementate - temprate -
rinvenute - rettificata

Case hardened - hardened
throughout - annealed and
ground

Trempés - cementés - revenus
et rectifiées

- Il diametro interno è rivestito
in bronzo
- Sede di montaggio h6
- Ogni bussola deve essere
fissata con 2 o 3 staffette e viti
a seconda la dimensione

- Staffette e viti a richiesta
- Clamps and screws
on request

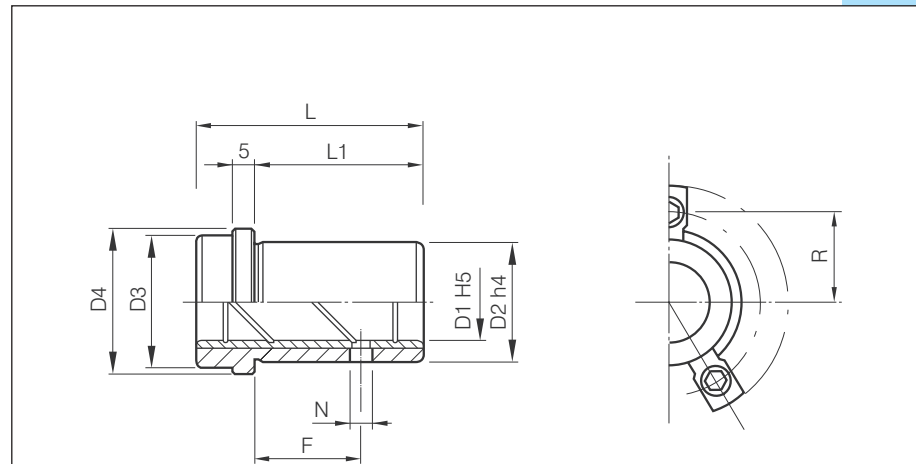

D1	B S B S								B S B L							
	L	D2	D3	D4	L1	R	N	F	L	D2	D3	D4	L1	R	N	F
18/19	31	28	29	34	18	21	5	8	50	28	29	34	37	21	5	8
24/25	36	38	39	44	23	26	5	12	55	38	39	44	42	26	5	12
30/32	43	45	48	53	30	31,5	5	16	60	45	48	53	47	31,5	5	16
40/42	51	54	58	63	38	36,5	8	19	67	54	58	63	54	36,5	8	19
50/52	61	65	74	79	48	44,5	8	19	75	65	74	79	62	44,5	8	19
63	74	81	87	92	61	51	8	19	63	90	81	92	77	51	8	19
80	91	100	106	111	78	60,5	8	19								

- A richiesta
- On request
- Sur demande
- Auf Anfrage

**Bussole estraibili
con scorrimento in bronzo**
Demountable bushes with bronze
Bagues demontable avec bronze
Führungsbuchse mit Bronze Auflage

**Acciaio
Steel
Acier
Werkstoff**

1.7131

**Durezza
Hardness
Dureté
Härte**

60-62 HRC

**Esecuzione
Finish
Exécution
Ausführung**

Cementate - temprate -
rinvenute - rettificata

Case hardened - hardened
throughout - annealed and
ground

Trempés - cementés - revenus
et rectifiés

- Il diametro interno è rivestito
in bronzo
- Sede di montaggio h6
- Ogni bussola deve essere
fissata con 2 o 3 staffette e viti
a seconda la dimensione

- Staffette e viti a richiesta
- Clamps and screws
on request

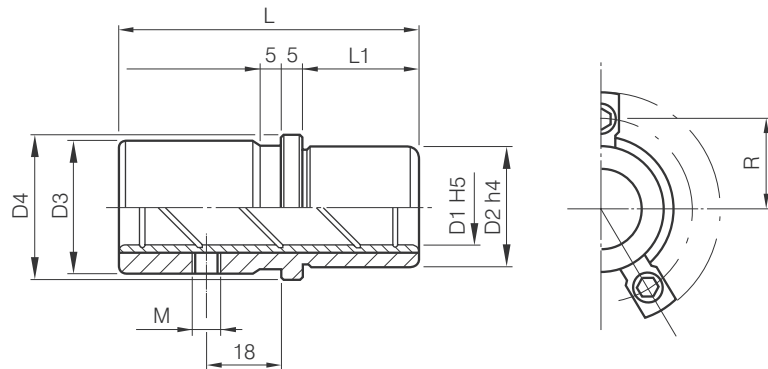

D1	BNBS							BLXS							BLBS						
	L	D2	D3	D4	L1	R	M	L	D2	D3	D4	L1	R	M	L	D2	D3	D4	L1	R	M
18/19	50	28	31	34	18	21	6X1	70	28	31	34	18	21	6X1	70	28	31	34	27	21	6X1
24/25	55	38	41	44	23	26	10X1	80	38	41	44	23	26	10X1	80	38	41	44	32	26	10X1
30/32	60	45	50	53	26	31,5	10X1	90	45	50	53	26	31,5	10X1	90	45	50	53	26	31,5	10X1
40/42	67	54	60	63	30	36,5	10X1	100	54	60	63	30	36,5	10X1	100	54	60	63	47	36,5	10X1
50/52	90	81	89	92	48	51	10X1	130	81	89	92	48	51	10X1	110	65	76	79	57	44,5	10X1
63	90	81	89	92	48	51	10X1	130	81	89	92	48	51	10X1	130	81	89	92	67	51	10X1
80	100	100	108	111	48	60,5	10X1	150	100	108	111	48	60,5	10X1	150	100	108	111	77	60,5	10X1

- A richiesta
- On request
- Sur demande
- Auf Anfrage

DIN 9825 ISO 9182

Acciaio
Steel
Acier
Werkstoff

18 Ni cr Mo

Durezza
Hardness
Durété
Härte

60-62 HRC

Esecuzione
Finish
Exécution
Ausführung

Cementate - Temprate -
 Rettificate - Lappate

Hardened - Case Hardened -
 Ground - Superfinished

Cementés - Trempés -
 Rectifiées - Polies

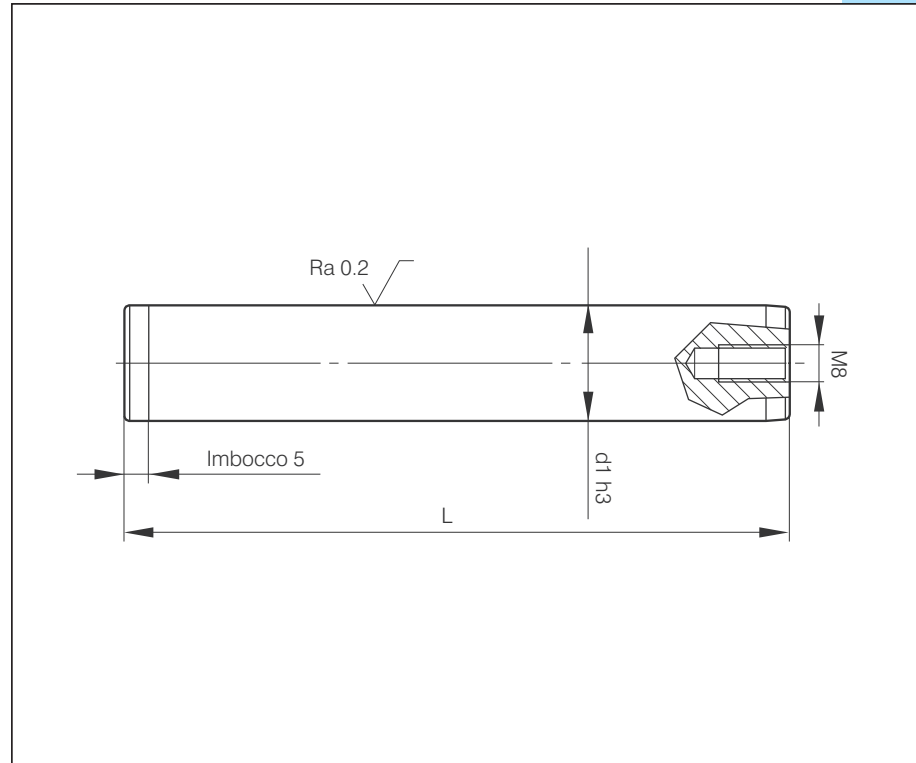

d1	90	100	110	125	140	150	160	170	180	190	200	220	240	260	280	300	315	355	400	450	500	550		
SENZA FILETTO / WITHOUT THREAD	4																							
	5																							
	6																							
	8																							
	10																							
	12																							
CON FILETTO M 8 / WITH THREAD M 8	15																							
	16																							
	19																							
	20																							
	24																							
	25																							
	30																							
	32																							
	38																							
	40																							
	48																							
	50																							
	63																							
	80	a richiesta / on request																						

ø 80 A richiesta
 ø 80 On request
 ø 80 Sur demande
 ø 80 AufAnfrage

Bussole guida con gabbia a sfere
Guide bushes with ball bearing sleeves
Bague de guidage avec cage à billes
Präzisions Führungsbuchse mit Kugelkäfige

Tipo R92

Acciaio
Steel
Acier
Werkstoff

18 Ni cr Mo5

Gabbia: Bronzo B14
 Sfera: Acciaio

Durezza
Hardness
Dureté
Härte

60-62 HRC

Esecuzione
Finish
Exécution
Ausführung

Cementate - Temprate -
 Rettificate - Lappate

Hardened - Case Hardened -
 Ground - Superfinished

Cementés - Trempés -
 Rectifiées - Polies

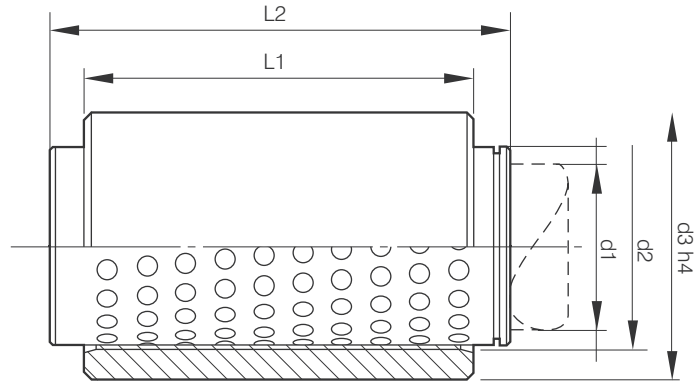

$D_1 h_3$	10	12	15	16	19	20	24	25	30	32	38	40	48	50	63	80
D_3	14	16	21	22	25	26	30	31	38	40	46	48	56	58	71	92
$D_2 h_4$	20	22	28	28	32	32	40	40	48	48	58	58	70	70	85	105
35	40															
35	45															
40	45															
45	56															
50	56															
50	63															
60	71															
70	80															
80	90															
90	100															
100	120															
120	140															

Questo tipo di guida è composta: da bussola di guida e gabbie a sfera.
 Si possono adattare con colonne toll H3 tipo DIN 9825.
 La bussola può essere inserita nel foro con esecuzione di un gioco di 0,4-0,6 mm. fra foro e bussola con collante oppure eseguendo un foro con tolleranza h6.

Unità di guida a sfere
Unit guide for ball bearing sleeves
Unité de guidage avec cage à bille
Führungseinheit mit Kugelkäfige

Tipo R93

Acciaio
Steel
Acier
Werkstoff

18 Ni cr Mo5

Gabbia: Bronzo B14
 Sfera: Acciaio

Durezza
Hardness
Dureté
Härte

60-62 HRC

Esecuzione
Finish
Exécution
Ausführung

Cementate - Temprate -
 Rettificate - Lappate

Hardened - Case Hardened -
 Ground - Superfinished

Cementés - Trepés -
 Rectifiées - Polies

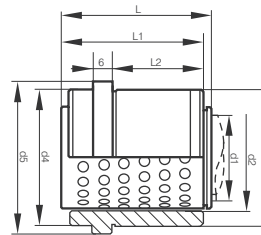

R 93C						
d1	19/20	24/25	30/32	38/40	48/50	63
d2	25/26	30/31	38/40	46/48	56/58	71
d3	32	40	48	58	70	85
d4	38	43	51	63	76	94
d5	40	45	54	66	80	95
d6	52	56	64	76	91	106
d7	67,9	71,8	81,7	92,7	106,6	121,5
L	45	45	56	63	80	95
L1	36	40	45	50	80	80
L2	23	27	32	37	67	67

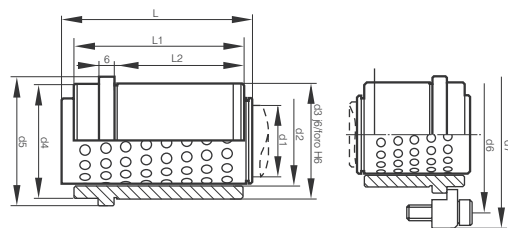

R 93M						
d1	19/20	24/25	30/32	38/40	48/50	63
d2	25/26	30/31	38/40	46/48	56/58	71
d3	32	40	48	58	70	85
d4	38	43	51	63	76	94
d5	40	45	54	66	80	95
d6	52	56	64	76	91	106
d7	67,9	71,8	81,7	92,7	106,6	121,5
L	45	71	80	80	100	120
L1	43	63	76	76	96	100
L2	30	48	61	61	78	78

La guida a sfera con collare deve essere inserita nel foro con tolleranza h6/j6.

Unità di guida a sfere
Unit guide for ball bearing sleeves
Unité de guidage avec cage à bille
Führungseinheit mit Kugelkäfige

Tipo R93

Acciaio
Steel
Acier
Werkstoff

18 Ni cr Mo5

Gabbia: Bronzo B14
 Sfera: Acciaio

Durezza
Hardness
Dureté
Härte

60-62 HRC

Esecuzione
Finish
Exécution
Ausführung

Cementate - Temprate -
 Rettificate - Lappate

Hardened - Case Hardened -
 Ground - Superfinished

Cementés - Trepés -
 Rectifiées - Polies

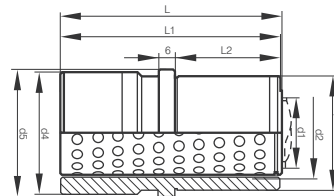

R 93L						
d1	19/20	24/25	30/32	38/40	48/50	63
d2	25/26	30/31	38/40	46/48	56/58	71
d3	32	40	48	58	70	85
d4	38	43	51	63	76	94
d5	40	45	54	66	80	95
d6	52	56	64	76	91	106
d7	67,9	71,8	81,7	92,7	106,6	121,5
L	71	80	100	100	100	120
L1	66	79	94	94	94	100
L2	30	38	48	48	57	57

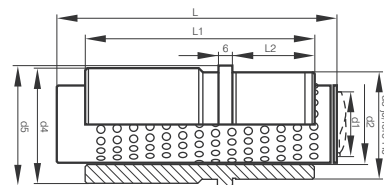

R 93EL						
d1	19/20	24/25	30/32	38/40	48/50	63
d2	25/26	30/31	38/40	46/48	56/58	71
d3	32	40	48	58	70	85
d4	38	43	51	63	76	94
d5	40	45	54	66	80	95
d6	52	56	64	76	91	106
d7	67,9	71,8	81,7	92,7	106,6	121,5
Staffetta	M6	M6	M8	M8	M8	M8
L	90	110	120	140	140	140
L1	80	90	100	112	130	130
L2	28	32	36	40	46	46

La guida a sfera con collare deve essere inserita nel foro con tolleranza h6/j6.

ISO 10243

Consigli, raccomandazioni e limiti

Le innovazioni tecnologiche introdotte ed utilizzate, permettono per la prima volta di fornire un'indicazione di durata minima delle molle alle deflessioni di lavoro minima e media.

Per un'ottimale utilizzo delle molle e per il rispetto dei valori indicativi di durata minima si raccomanda sempre:

- selezionare accuratamente le molle sempre in fase di progettazione;
- guida interna con spina o esterna con foro di alloggiamento assolutamente necessari per rapporti tra lunghezza libera e diametro superiori a 3.5;
- massima perpendicolarità delle molle rispetto ai piani di appoggio e compressione;
- precarico minimo del 5% della lunghezza libera;
- utilizzo di molle con lunghezza maggiore e carico inferiore. Sarà conseguentemente aumentata la freccia di precarico;
- non utilizzare le molle (precarico e corsa lavoro) oltre la deflessione massima prevista a catalogo, colonna "C";
- verificare sempre le altezze di alloggiamento e le corse di lavoro degli elementi elastici dopo la riaffilatura degli utensili nello stampo. Normalmente tale operazione aumenta la freccia complessiva di compressione;
- proteggere le molle da elementi corrosivi;
- non superare temperature di utilizzo di 250°C. Fino alla temperatura di 120°C non si hanno perdite di carico significative, oltre considerare una perdita di carico del 1% circa ogni 40°C;
- non sostituire solo una molla, ma procedere con una manutenzione programmata di tutte le molle utilizzate;
- non alterare le condizioni fisiche delle molle (tagli, molature interne e/o esterne).

I valori indicativi di durata minima decadono sempre qualora non soddisfatti i punti di cui sopra. Per contro l'utilizzo corretto delle molle è sempre garanzia di massime prestazioni ben superiori alle indicazioni di durata minima fornite come confermano con soddisfazione tutti gli utilizzatori.

Advice, prescriptions and limitations

For the first time, technological innovations introduced and used make it possible to indicate the minimum lifetime of springs under minimum and average working deflections.

For optimum use of the springs, and to obtain the minimum lifetime values indicated, observe the following guide lines:

- select springs carefully at the design stage;
- use a guide pin, a locating bore as a guide – this is essential for springs having a free length/diameter ratio exceeding 3.5;
- assure perpendicularity of the springs to the supporting and compression surfaces;
- apply a minimum pre-load of 5% of the free length;
- use longer springs at lower loadings where possible (pre-loading must be suitably increased);
- never compress springs beyond the maximum deflection (pre-load and working stroke) specified in column "C" of the catalogue;
- always check spring holder heights and working strokes of moving elements after die tools have been re-ground. Normally this operation causes an increase in the overall compression of the springs;
- protect springs from corrosive agents;
- do not exceed a working temperature of 250 °C. Up to 120 °C no significant load reduction occurs, beyond this temperature an average loss of 1% for every 40 °C must be calculated;
- do not replace one spring at a time; instead, adopt a programmed maintenance procedure in which all the springs are changed at the same time;
- do not alter the physical characteristics of springs (cutting, internal and/or external grinding).

Guideline minimum lifetime indications are invalidated immediately if the above conditions are not complied with.

When used correctly, the springs ensure performance levels well above the minimum lifetime values indicated, as confirmed by feedback from all the end users.

ISO 10243

Ratschläge, empfehlungen und grenzen

Die von unsere eingeführten und angewandten technologischen Innovationen gestatten zum ersten Mal, Angaben bezüglich der Mindesthaltbarkeit der Federn unter Berücksichtigung der geringsten bis mittleren Durchbiegungen während des Einsatzes zu machen.

Für eine optimale Verwendung der Federn und für die Einhaltung der Richtwerte der Mindesthaltbarkeit wird immer empfohlen:

- die Federn immer schon bei der Planung akkurat wählen;
- innere Führung mit Stift oder Außenführung mit Aufnahmebohrung sind unbedingt notwendig für Verhältnisse zwischen freier Länge und Durchmesser über 3.5;
- maximale Rechtwinkligkeit der Federn zu den Auflage- und Einfederungsebenen;
- mindestvorspannung 5% der freien Länge;
- Verwendung der Federn mit größerer Länge und geringerer Belastung. Folglich wird die Vorspannungsweite erhöht;
- bei Benutzung der Federn nicht die im Katalog, Spalte "C" genannte maximal zulässige Durchbiegung (Vorspannung und Arbeitsfederweg) übersteigen;
- nach dem Nachschliff der Werkzeuge in der Form immer die Höhe der Aufnahmen und die Arbeitshübe der elastischen Elemente kontrollieren. Normalerweise wird durch diesen Vorgang die Gesamteinfederung erhöht;
- die Federn vor korrosiven Elementen schützen;
- die Einsatztemperatur von 250 °C nicht überschreiten. Bis zur Temperatur von 120 °C gibt es keine nennenswerten Spannungsverluste, darüber muss ein Spannungsverlust von ca. 1% alle 40 °C berücksichtigt werden;
- niemals nur eine Feder ersetzen, sondern die Wartung aller verwendeten Federn programmieren;
- den physischen Zustand der Federn nicht verändern (Schnitte, innerer und/oder äußerer Schliff).

Die Richtwerte der Mindesthaltbarkeit haben keine Gültigkeit, wenn die obengenannten Punkte nicht eingehalten werden.

Die korrekte Benutzung der Federn ist dagegen immer eine Garantie für maximale Leistungen, die weit über der angegebenen Mindesthaltbarkeit liegen, wie die Zufriedenheit aller Benutzer bestätigt.

Conseils, recommandations et limites

Les innovations technologiques introduites et utilisées permettent pour la première fois de fournir une indication de durée minimale des ressorts par rapport aux déflexions minimales et moyennes.

Pour une utilisation optimale des ressorts et pour le respect des valeurs de durée minimale fournies à titre indicatif, il est recommandé de:

- toujours sélectionner soigneusement les ressorts pendant la phase de conception;
- assurer un guidage intérieur par goujon ou extérieur par trou de logement, absolument nécessaires afin d'obtenir des rapports supérieurs à 3.5 entre ongueur libre et diamètre;
- obtenir une perpendicularité maximale des ressorts par rapport aux plans d'appui et de compression;
- avoir une précontrainte minimale de 5% de la longueur libre;
- utiliser des ressorts ayant une longueur supérieure et une compression inférieure. Par conséquent, la flèche de précontrainte augmentera;
- ne pas utiliser les ressorts (précontrainte et course travail) au-delà de la déflexion maximale prévue sur catalogue, colonne "C";
- toujours vérifier les hauteurs de logement et les courses de travail des éléments élastiques après le réaffutage des outils dans le moule. Normalement, cette opération augmente la flèche de compression globale;
- protéger les ressorts contre les éléments corrosifs;
- ne pas dépasser des températures d'utilisation de 250 °C. Jusqu'à une température de 120 °C, il n'y a pas de pertes de charge significatives; en outre, considérer une perte de charge de 1% environ tous les 40 °C;
- ne pas remplacer un seul ressort mais effectuer un entretien programmé de tous les ressorts utilisés;
- ne pas altérer les caractéristiques physiques des ressorts (par coupures, meulages internes et/ou externes).

Les valeurs relatives à la durée minimale fournies à titre indicatif ne sont pas valables si les conditions indiquées ci-dessus ne sont pas remplies.

Par contre, l'utilisation correcte des ressorts est toujours une garantie de performances nettement supérieures aux indications de durée minimale fournies, comme le confirment avec satisfaction tous les utilisateurs.

Legenda delle tabelle





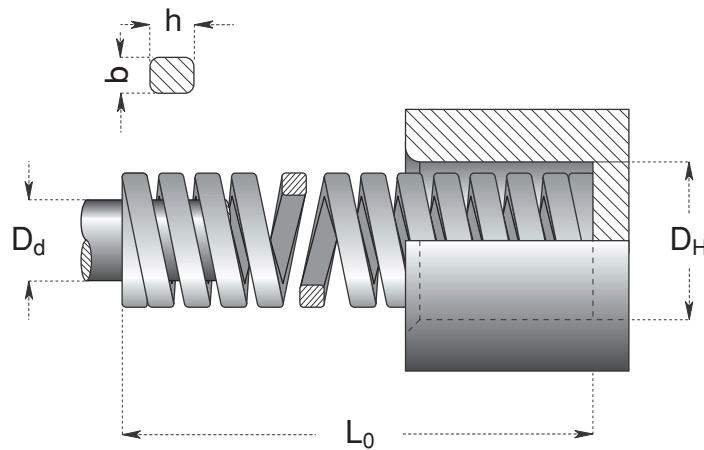





Explanation of the spring table Tabellenangaben Légende des tableaux

BM
Industrie

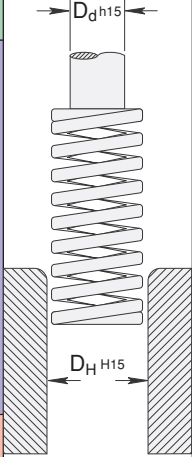

D_H	D_d	L_0	N. di catalogo Catalogue No. Bestellnummer N° de catalogue	R	A	B	C	D	
x h, d					XXX	YYY	Max. Def.	Approx.	
mm	mm	mm		N / mm	mm N	mm N	mm N	mm N	
D	diametro de foro di alloggiamento				D	ho e diameter			
D_d	diametro de a s ina di guida				D_d	rod diameter			
xh, d	sezione de rofi o				xh, d	cross wire section			
L_0	unghezza i era de a mo a				L_0	s ring free length			
R	carico N necessario er def ettere a mo a di 1 millimetro				R	s ring rate load required for 1mm def ection			
A	def essione tota e consig iata er una unga durata de a mo a				A	ad ised wor ing def ection for ong s ring life			
	indicazione di durata minima					minimum estimated life			
B	def essione tota e consig iata er una media durata de a mo a				B	ad ised wor ing def ection for medium s ring life			
	indicazione di durata minima					minimum estimated life			
C	def essione tota e massima consentita				C	maximum o erating def ection			
D	def essione a rossimati a er mo a aocco				D	solid def ection a roximate a ue			
D	Au enf hrungsdurchmesser				D	diam tre du trou de ogement			
D_d	Innenf hrungsdurchmesser				D_d	diam tre de ar re de guidage			
xh, d	rofi querschnitt				xh, d	section du rofi e			
L_0	L nge der un e asteten Feder				L_0	ongueur i re du ressort			
R	Federrate				R	charge exig e our com rimer e ressort 1mm			
A	Em foh ene Federweg f r ange Le ensdauer				A	course consei e our une ongue dure du ressort			
	inima e gesch zte e ensdauer					indication de dure minima e			
B	Em foh ene Federweg f r mittere Le ensdauer				B	course consei e our dure mo enne du ressort			
	inima e gesch tzte e ensdauer					indication de dure minima e			
C	maxima er au ter Federweg				C	f che maximale our e fonctionnement			
D	Federweg is Bocco nge				D	f che oc a eur a roximate e			

Caratteristiche e tolleranze Characteristics and tolerances Merkmale und toleranzen Caractéristiques et tolérances

Serie Series serie série	Sez. profilo Cross section Profilquerschnitt Section du profilé	Colore Color Kennfarbe Couleur	Carico Load Belastung Charge	Mass. defless. M ax. deflection M ax. Federweg Flèche max.	Diametri Diameters Durchmesser Diamètre	Lungh. libera Free length Länge Long. libre	Rigidità Rate Rigidez Râideur
CXL 		Verde chiaro Light green Hellgrün Verte claire (RAL 6019)	Extra-leggero Extra-light Leichte Extra-légère	50 % L_0			
CLV  ISO 10243		Verde Green Grün verte (RAL 6002)	Leggero Light Normale Légère	40 % L_0			
CM B  ISO 10243		Blu Blue Blau Bleu (RAL 5003)	Medio Medium Mittlere Moyenne	37,5 % L_0		$\pm 1 \% L_0$ $\pm 0,75 \text{ min.}$	$\pm 10 \%$
CFR  ISO 10243		Rosso Red Rot Rouge (RAL 3000)	Forte Heavy Hohe Forte	30 % L_0			
CXF  ISO 10243		Giallo Yellow Gelb Jaune (RAL 1004)	Extra-Forte Extra-heavy Höchste Extra-Forte	25 % L_0			



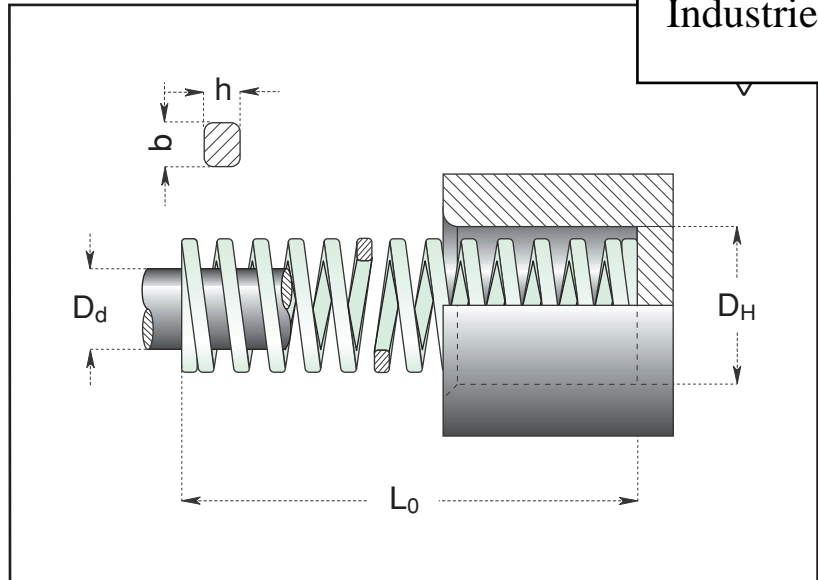

Molle carico extra-leggero
Extra-light load springs
Federn für leichte belastung
Ressorts charge extra-légère

Serie Series Serie Série CXL



D_H	D_d	L_0	N. di catalogo Catalogue No. Bestellnummer N° de catalogue	Rigidità Rate Rigidez Raideur	30%		40%		50%		D	
					3.000.000	1.500.000	M ax. Def.	Approx.				
x h				N / mm	mm	N	mm	N	mm	N	mm	N
mm	mm	mm										
20	10	25	CXL 20 - 025	29.4	7.5	221	10.0	294	12.5	368	13.9	409
		32	CXL 20 - 032	22.6	9.6	217	12.8	289	16.0	362	18.2	411
		38	CXL 20 - 038	18.6	11.4	212	15.2	283	19.0	353	22.0	409
		44	CXL 20 - 044	15.7	13.2	207	17.6	276	22.0	345	25.8	405
		51	CXL 20 - 051	13.7	15.3	210	20.4	279	25.5	349	30.3	415
		64	CXL 20 - 064	11.3	19.2	217	25.6	289	32.0	362	38.9	440
		76	CXL 20 - 076	9.8	22.8	223	30.4	298	38.0	372	47.0	461
		89	CXL 20 - 089	8.3	26.7	222	35.6	295	44.5	369	55.7	462
		102	CXL 20 - 102	7.4	30.6	226	40.8	302	51.0	377	64.2	475
		115	CXL 20 - 115	6.4	34.5	221	46.0	294	57.5	368	72.9	467
		127	CXL 20 - 127	5.9	38.1	225	50.8	300	63.5	375	80.7	476
		139	CXL 20 - 139	5.4	41.7	225	55.6	300	69.5	375	88.4	477
		152	CXL 20 - 152	4.9	45.6	223	60.8	298	76.0	372	96.7	474
		305	CXL 20 - 305	2.5	91.5	229	122.0	305	152.5	381	196.3	491
25	12.5	25	CXL 25 - 025	53.9	7.5	404	10.0	539	12.5	674	12.9	695
		32	CXL 25 - 032	42.2	9.6	405	12.8	540	16.0	675	17.2	726
		38	CXL 25 - 038	35.8	11.4	408	15.2	544	19.0	680	20.7	741
		44	CXL 25 - 044	31.4	13.2	414	17.6	553	22.0	691	24.4	766
		51	CXL 25 - 051	27.0	15.3	413	20.4	551	25.5	689	28.5	770
		64	CXL 25 - 064	21.6	19.2	415	25.6	553	32.0	691	36.5	788
		76	CXL 25 - 076	18.1	22.8	413	30.4	550	38.0	688	43.9	795
		89	CXL 25 - 089	15.2	26.7	406	35.6	541	44.5	676	51.4	781
		102	CXL 25 - 102	13.2	30.6	404	40.8	539	51.0	673	59.3	783
		115	CXL 25 - 115	11.8	34.5	407	46.0	543	57.5	679	67.2	793
		127	CXL 25 - 127	10.6	38.1	404	50.8	538	63.5	673	74.4	789
		139	CXL 25 - 139	9.6	41.7	400	55.6	534	69.5	667	81.6	783
		152	CXL 25 - 152	8.8	45.6	401	60.8	535	76.0	669	89.5	788
		178	CXL 25 - 178	7.6	53.4	406	71.2	541	89.0	676	105.4	801
203	CXL 25 - 203	6.7	60.9	408	81.2	544	101.5	680	120.7	809		
305	CXL 25 - 305	4.4	91.5	403	122.0	537	152.5	671	182.4	803		
32	16	38	CXL 32 - 038	43.1	11.4	491	15.2	655	19.0	819	19.9	858
		44	CXL 32 - 044	37.3	13.2	492	17.6	656	22.0	821	23.5	877
		51	CXL 32 - 051	32.4	15.3	496	20.4	661	25.5	826	27.6	894
		64	CXL 32 - 064	25.5	19.2	490	25.6	653	32.0	816	35.2	898
		76	CXL 32 - 076	21.6	22.8	492	30.4	657	38.0	821	42.4	916
		89	CXL 32 - 089	18.1	26.7	483	35.6	644	44.5	805	50.0	905
		102	CXL 32 - 102	15.7	30.6	480	40.8	641	51.0	801	57.6	904
		115	CXL 32 - 115	14.2	34.5	490	46.0	653	57.5	817	65.5	930
		127	CXL 32 - 127	12.7	38.1	484	50.8	645	63.5	806	72.5	921
		139	CXL 32 - 139	11.6	41.7	484	55.6	645	69.5	806	79.4	921
		152	CXL 32 - 152	10.6	45.6	483	60.8	644	76.0	806	87.3	925
		178	CXL 32 - 178	9.0	53.4	481	71.2	641	89.0	801	102.9	926
		203	CXL 32 - 203	7.8	60.9	475	81.2	633	101.5	792	117.7	918
		254	CXL 32 - 254	6.4	76.2	488	101.6	650	127.0	813	148.1	948
305	CXL 32 - 305	5.3	91.5	485	122.0	647	152.5	808	178.3	945		
6.5 x 2.6												

Colore verde chiaro Light green color Kennfarbe hellgrün Couleur verte claire
Filo rettangolare Rectangular wire Reckteckigem drahtquerschnitt Fil rectangulaire

D_H	D_d	L₀	N. di catalogo Catalogue No. Bestellnummer N° de catalogue	Rigidità Rate Rigidez Raideur	30%		40%		50%		D	
					 3.000.000	 1.500.000	 M aX. Defl.	 Approx.	mm	N		
x h		mm		N / mm	mm	N	mm	N	mm	N	mm	N
40	20	51	CXL 40 - 051	48.1	15.3	736	20.4	981	25.5	1227	28.0	1347
		64	CXL 40 - 064	39.2	19.2	753	25.6	1004	32.0	1254	36.2	1419
		76	CXL 40 - 076	33.3	22.8	759	30.4	1012	38.0	1265	43.7	1455
		89	CXL 40 - 089	28.4	26.7	758	35.6	1011	44.5	1264	51.7	1468
		102	CXL 40 - 102	24.5	30.6	750	40.8	1000	51.0	1250	59.8	1465
		115	CXL 40 - 115	22.1	34.5	762	46.0	1017	57.5	1271	67.9	1501
		127	CXL 40 - 127	19.6	38.1	747	50.8	996	63.5	1245	75.2	1474
		139	CXL 40 - 139	17.7	41.7	738	55.6	984	69.5	1230	82.4	1458
		152	CXL 40 - 152	16.2	45.6	739	60.8	985	76.0	1231	90.6	1468
		178	CXL 40 - 178	13.7	53.4	732	71.2	975	89.0	1219	106.5	1459
		203	CXL 40 - 203	12.3	60.9	749	81.2	999	101.5	1248	122.2	1503
		254	CXL 40 - 254	9.8	76.2	747	101.6	996	127.0	1245	153.6	1505
8.0 x 3.4		305	CXL 40 - 305	8.3	91.5	759	122.0	1013	152.5	1266	185.4	1539
50	25	64	CXL 50 - 064	86.3	19.2	1657	25.6	2209	32.0	2762	35.1	3029
		76	CXL 50 - 076	70.6	22.8	1610	30.4	2146	38.0	2683	42.2	2979
		89	CXL 50 - 089	59.8	26.7	1597	35.6	2129	44.5	2661	50.3	3008
		102	CXL 50 - 102	52.0	30.6	1591	40.8	2122	51.0	2652	58.4	3037
		115	CXL 50 - 115	46.1	34.5	1590	46.0	2121	57.5	2651	66.1	3047
		127	CXL 50 - 127	42.2	38.1	1608	50.8	2144	63.5	2680	73.8	3114
		139	CXL 50 - 139	38.2	41.7	1593	55.6	2124	69.5	2655	80.9	3090
		152	CXL 50 - 152	34.3	45.6	1564	60.8	2085	76.0	2607	89.0	3053
		178	CXL 50 - 178	29.4	53.4	1570	71.2	2093	89.0	2617	105.3	3096
		203	CXL 50 - 203	25.5	60.9	1553	81.2	2071	101.5	2588	120.6	3075
		254	CXL 50 - 254	20.6	76.2	1570	101.6	2093	127.0	2616	152.2	3135
		10.5 x 4.1		305	CXL 50 - 305	17.2	91.5	1574	122.0	2098	152.5	2623

Note 1 N 0,102 g force

bmindustrie

Molle carico leggero
Light load springs
Federn für normale belastung
Ressorts charge légère

Serie Series Serie Série CLV

ISO 10243

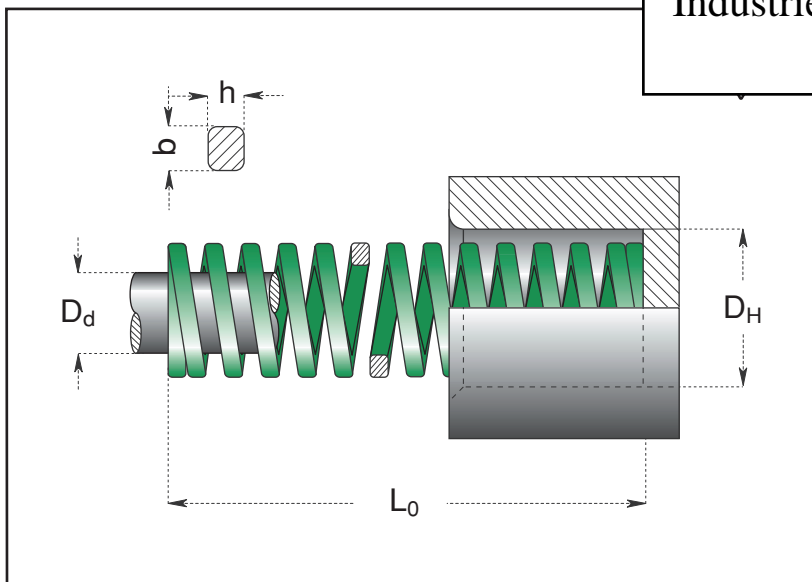

D _H	D _d	L ₀	N. di catalogo Catalogue No. Bestellnummer N° de catalogue	Rigidità Rate Rigidez Raideur	25%		30%		40%		D	
					3.000.000	1.500.000	M aX. Defl.	Approx.				
x h				N / mm	mm	N	mm	N	mm	N	mm	N
mm	mm	mm										
10	5	25	CLV 10 - 025	10	6.3	63	7.5	75	10.0	100	13.5	135
		32	CLV 10 - 032	8.5	8.0	68	9.6	82	12.8	109	17.5	149
		38	CLV 10 - 038	6.8	9.5	65	11.4	78	15.2	103	20.8	141
		44	CLV 10 - 044	6.0	11.0	66	13.2	79	17.6	106	23.9	143
		51	CLV 10 - 051	5.0	12.8	64	15.3	77	20.4	102	28.9	145
		64	CLV 10 - 064	4.3	16.0	69	19.2	83	25.6	110	36.1	155
		76	CLV 10 - 076	3.2	19.0	61	22.8	73	30.4	97	43.2	138
		305	CLV 10 - 305	1.1	76.3	84	91.5	101	122.0	134	178.7	197
12.5	6.3	25	CLV 13 - 025	17.9	6.3	113	7.5	134	10.0	179	13.2	236
		32	CLV 13 - 032	16.4	8.0	131	9.6	157	12.8	210	18.0	295
		38	CLV 13 - 038	13.6	9.5	129	11.4	155	15.2	207	21.0	286
		44	CLV 13 - 044	12.1	11.0	133	13.2	160	17.6	213	24.0	290
		51	CLV 13 - 051	11.4	12.8	146	15.3	174	20.4	233	28.7	327
		64	CLV 13 - 064	9.3	16.0	149	19.2	179	25.6	238	35.8	333
		76	CLV 13 - 076	7.1	19.0	135	22.8	162	30.4	216	42.7	303
		89	CLV 13 - 089	5.4	22.3	120	26.7	144	35.6	192	50.4	272
		102	CLV 13 - 102	4.1	25.5	105	30.6	125	40.8	167	58.4	239
		305	CLV 13 - 305	1.4	76.3	107	91.5	128	122.0	171	172.0	241
16	8	25	CLV 16 - 025	23.4	6.3	147	7.5	176	10.0	234	12.6	295
		32	CLV 16 - 032	22.9	8.0	183	9.6	220	12.8	293	16.4	376
		38	CLV 16 - 038	19.3	9.5	183	11.4	220	15.2	293	19.7	380
		44	CLV 16 - 044	17.1	11.0	188	13.2	226	17.6	301	22.5	385
		51	CLV 16 - 051	15.7	12.8	201	15.3	240	20.4	320	26.3	413
		64	CLV 16 - 064	10.7	16.0	171	19.2	205	25.6	274	33.3	356
		76	CLV 16 - 076	10.0	19.0	190	22.8	228	30.4	304	40.2	402
		89	CLV 16 - 089	8.6	22.3	192	26.7	230	35.6	306	47.6	409
		102	CLV 16 - 102	7.8	25.5	199	30.6	239	40.8	318	55.4	432
		115	CLV 16 - 115	6.6	28.8	190	34.5	228	46.0	304	60.8	401
305	CLV 16 - 305	2.5	76.3	191	91.5	229	122.0	305	165.3	413		
20	10	25	CLV 20 - 025	55.8	6.3	352	7.5	419	10.0	558	12.1	675
		32	CLV 20 - 032	45.0	8.0	360	9.6	432	12.8	576	15.3	689
		38	CLV 20 - 038	33.3	9.5	316	11.4	380	15.2	506	18.9	629
		44	CLV 20 - 044	30.0	11.0	330	13.2	396	17.6	528	21.5	645
		51	CLV 20 - 051	24.5	12.8	314	15.3	375	20.4	500	25.0	613
		64	CLV 20 - 064	20.0	16.0	320	19.2	384	25.6	512	31.1	622
		76	CLV 20 - 076	16.0	19.0	304	22.8	365	30.4	486	37.3	597
		89	CLV 20 - 089	14.0	22.3	312	26.7	374	35.6	498	44.5	623
		102	CLV 20 - 102	12.0	25.5	306	30.6	367	40.8	490	51.1	613
		115	CLV 20 - 115	10.9	28.8	314	34.5	376	46.0	501	58.2	634
		127	CLV 20 - 127	9.5	31.8	302	38.1	362	50.8	483	64.9	617
		139	CLV 20 - 139	8.4	35.0	294	42.0	353	56.0	470	71.5	601
		152	CLV 20 - 152	7.5	38.0	285	45.6	342	60.8	456	78.8	591
		305	CLV 20 - 305	4.0	76.3	305	91.5	366	122.0	488	157.4	630
4.0 x 2.1												

D _H	D _d	L ₀	N. di catalogo Catalogue No. Bestellnummer N° de catalogue	Rigidità Rate Rigidez Raideur	25%		30%		40%		D			
					3.000.000		1.500.000		M aX. Defl.		Approx.			
x h					mm	N	mm	N	mm	N	mm	N		
mm	mm	mm		N / mm										
25	12.5	25	CLV 25 - 025	100.0	6.3	630	7.5	750	10.0	1000	11.9	1190		
		32	CLV 25 - 032	80.3	8.0	642	9.6	771	12.8	1028	16.0	1285		
		38	CLV 25 - 038	62.0	9.5	589	11.4	707	15.2	942	18.3	1135		
		44	CLV 25 - 044	52.9	11.0	582	13.2	698	17.6	931	21.4	1132		
		51	CLV 25 - 051	44.0	12.8	563	15.3	673	20.4	898	24.9	1096		
		64	CLV 25 - 064	35.2	16.0	563	19.2	676	25.6	901	31.4	1105		
		76	CLV 25 - 076	28.0	19.0	532	22.8	638	30.4	851	37.5	1050		
		89	CLV 25 - 089	24.0	22.3	535	26.7	641	35.6	854	43.5	1044		
		102	CLV 25 - 102	21.1	25.5	538	30.6	646	40.8	861	51.1	1078		
		115	CLV 25 - 115	18.7	28.8	539	34.5	645	46.0	860	58.1	1086		
		127	CLV 25 - 127	16.7	31.8	531	38.1	636	50.8	848	64.1	1070		
		139	CLV 25 - 139	15.3	35.0	536	42.0	643	56.0	857	70.4	1077		
		152	CLV 25 - 152	14.0	38.0	532	45.6	638	60.8	851	77.1	1079		
		178	CLV 25 - 178	12.5	44.5	556	53.4	668	71.2	890	93.1	1164		
5.4 x 2.7		203	CLV 25 - 203	10.4	50.8	528	60.9	633	81.2	844	102.7	1068		
		305	CLV 25 - 305	7.0	76.3	534	91.5	641	122.0	854	155.9	1091		
32	16	38	CLV 32 - 038	94.0	9.5	893	11.4	1072	15.2	1429	18.3	1720		
		44	CLV 32 - 044	79.5	11.0	875	13.2	1049	17.6	1399	21.5	1709		
		51	CLV 32 - 051	67.0	12.8	858	15.3	1025	20.4	1367	25.5	1709		
		64	CLV 32 - 064	53.0	16.0	848	19.2	1018	25.6	1357	31.9	1691		
		76	CLV 32 - 076	44.0	19.0	836	22.8	1003	30.4	1338	38.6	1698		
		89	CLV 32 - 089	37.2	22.3	830	26.7	993	35.6	1324	46.5	1730		
		102	CLV 32 - 102	32.0	25.5	816	30.6	979	40.8	1306	53.2	1702		
		115	CLV 32 - 115	29.0	28.8	835	34.5	1001	46.0	1334	60.0	1740		
		127	CLV 32 - 127	25.0	31.8	795	38.1	953	50.8	1270	66.7	1668		
		139	CLV 32 - 139	23.0	35.0	805	42.0	966	56.0	1288	71.8	1651		
		152	CLV 32 - 152	21.5	38.0	817	45.6	980	60.8	1307	78.5	1688		
		178	CLV 32 - 178	18.2	44.5	810	53.4	972	71.2	1296	94.4	1718		
		203	CLV 32 - 203	15.8	50.8	803	60.9	962	81.2	1283	107.1	1692		
		6.8 x 3.3		254	CLV 32 - 254	12.5	63.5	794	76.2	953	101.6	1270	136.5	1706
		305	CLV 32 - 305	10.3	76.3	786	91.5	942	122.0	1257	162.7	1676		
40	20	51	CLV 40 - 051	92.0	12.8	1178	15.3	1408	20.4	1877	25.5	2346		
		64	CLV 40 - 064	73.0	16.0	1168	19.2	1402	25.6	1869	31.4	2292		
		76	CLV 40 - 076	63.0	19.0	1197	22.8	1436	30.4	1915	37.8	2381		
		89	CLV 40 - 089	51.0	22.3	1137	26.7	1362	35.6	1816	44.3	2259		
		102	CLV 40 - 102	43.0	25.5	1097	30.6	1316	40.8	1754	50.7	2180		
		115	CLV 40 - 115	39.6	28.8	1140	34.5	1366	46.0	1822	58.1	2301		
		127	CLV 40 - 127	37.0	31.8	1177	38.1	1410	50.8	1880	64.6	2390		
		139	CLV 40 - 139	32.0	35.0	1120	42.0	1344	56.0	1792	70.1	2243		
		152	CLV 40 - 152	28.0	38.0	1064	45.6	1277	60.8	1702	76.6	2145		
		178	CLV 40 - 178	25.2	44.5	1121	53.4	1346	71.2	1794	90.4	2278		
		203	CLV 40 - 203	22.7	50.8	1153	60.9	1382	81.2	1843	102.4	2324		
		8.1 x 4.0		254	CLV 40 - 254	17.0	63.5	1080	76.2	1295	101.6	1727	128.8	2190
				305	CLV 40 - 305	14.8	76.3	1129	91.5	1354	122.0	1806	156.1	2310
		50	25	64	CLV 50 - 064	156	16.0	2496	19.2	2995	25.6	3994	31.0	4836
76	CLV 50 - 076			125	19.0	2375	22.8	2850	30.4	3800	37.2	4650		
89	CLV 50 - 089			109	22.3	2431	26.7	2910	35.6	3880	43.6	4752		
102	CLV 50 - 102			94.0	25.5	2397	30.6	2876	40.8	3835	50.3	4728		
115	CLV 50 - 115			81.0	28.8	2333	34.5	2795	46.0	3726	58.1	4706		
127	CLV 50 - 127			71.0	31.8	2258	38.1	2705	50.8	3607	63.7	4523		
139	CLV 50 - 139			66.5	35.0	2328	42.0	2793	56.0	3724	69.5	4622		
152	CLV 50 - 152			60.0	38.0	2280	45.6	2736	60.8	3648	76.5	4590		
178	CLV 50 - 178			52.0	44.5	2314	53.4	2777	71.2	3702	91.9	4779		
203	CLV 50 - 203			44.0	50.8	2235	60.9	2680	81.2	3573	104.7	4607		
10.9 x 5.3				254	CLV 50 - 254	35.0	63.5	2223	76.2	2667	101.6	3556	130.6	4571
		305	CLV 50 - 305	28.5	76.3	2175	91.5	2608	122.0	3477	154.9	4415		
63	38	76	CLV 63 - 076	189	19.0	3591	22.8	4309	30.4	5746	36.5	6899		
		89	CLV 63 - 089	158	22.3	3523	26.7	4219	35.6	5625	43.4	6857		
		102	CLV 63 - 102	131	25.5	3341	30.6	4009	40.8	5345	49.7	6511		
		115	CLV 63 - 115	116	28.8	3341	34.5	4002	46.0	5336	55.6	6450		
		127	CLV 63 - 127	103	31.8	3275	38.1	3924	50.8	5232	62.7	6458		
		152	CLV 63 - 152	84.3	38.0	3203	45.6	3844	60.8	5125	77.1	6500		
		178	CLV 63 - 178	71.5	44.5	3182	53.4	3818	71.2	5091	92.2	6592		
		203	CLV 63 - 203	61.7	50.8	3134	60.9	3758	81.2	5010	103.5	6386		
		254	CLV 63 - 254	47.0	63.5	2985	76.2	3581	101.6	4775	130.4	6129		
		11.0 x 7.8		305	CLV 63 - 305	38.2	76.3	2915	91.5	3495	122.0	4660	157.4	6013

Molle carico medio
Medium load springs
Federn für mittlere belastung
Ressorts charge moyenne

Serie Series Serie Série CMB

ISO 10243

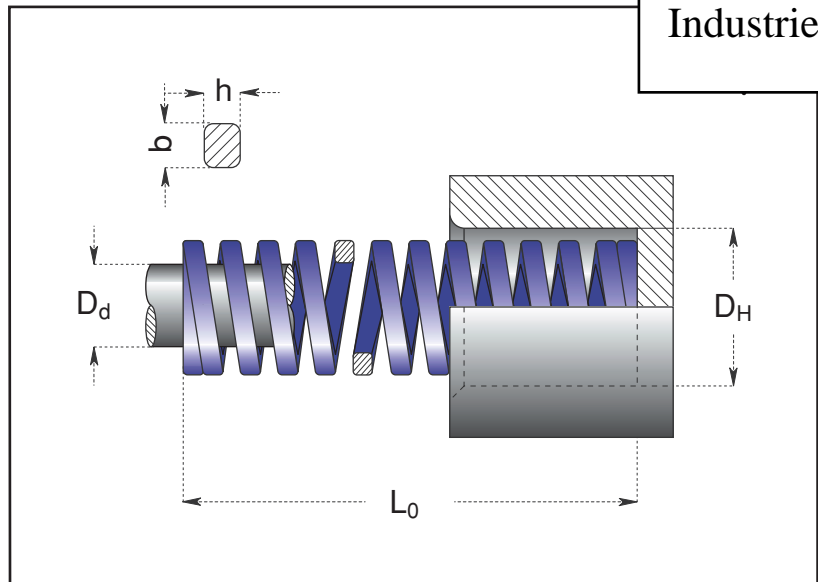

D _H	D _d	L ₀	N. di catalogo Catalogue No. Bestellnummer N° de catalogue	Rigidità Rate Rigidez Raideur	25%		30%		37.5%		D	
					3.000.000		1.500.000		M aX. Defl.		Approx.	
x h				N / mm	mm	N	mm	N	mm	N	mm	N
mm	mm	mm										
10	5	25	CM B 10 - 025	16.0	6.3	101	7.5	120	9.4	150	10.2	163
		32	CM B 10 - 032	13.0	8.0	104	9.6	125	12.0	156	14.2	185
		38	CM B 10 - 038	11.9	9.5	113	11.4	136	14.3	170	16.8	200
		44	CM B 10 - 044	10.3	11.0	113	13.2	136	16.5	170	19.4	200
		51	CM B 10 - 051	8.9	12.8	114	15.3	136	19.1	170	23.4	208
		64	CM B 10 - 064	7.5	16.0	120	19.2	144	24.0	180	28.2	212
		76	CM B 10 - 076	5.3	19.0	101	22.8	121	28.5	151	34.2	181
		305	CM B 10 - 305	1.6	76.3	122	91.5	146	114.4	183	133.8	214
12.5	6.3	25	CM B 13 - 025	30.0	6.3	189	7.5	225	9.4	282	11.9	357
		32	CM B 13 - 032	24.8	8.0	198	9.6	238	12.0	298	16.2	402
		38	CM B 13 - 038	21.4	9.5	203	11.4	244	14.3	306	18.7	400
		44	CM B 13 - 044	18.5	11.0	204	13.2	244	16.5	305	21.3	394
		51	CM B 13 - 051	15.5	12.8	198	15.3	237	19.1	296	25.6	397
		64	CM B 13 - 064	12.1	16.0	194	19.2	232	24.0	290	32.4	392
		76	CM B 13 - 076	10.2	19.0	194	22.8	233	28.5	291	39.0	398
		89	CM B 13 - 089	8.4	22.3	187	26.7	224	33.4	281	45.9	386
		102	CM B 13 - 102	6.3	25.5	161	30.6	193	38.3	241	52.3	329
		305	CM B 13 - 305	2.1	76.3	160	91.5	192	114.4	240	152.5	320
16	8	25	CM B 16 - 025	49.4	6.3	311	7.5	371	9.4	464	10.5	519
		32	CM B 16 - 032	37.1	8.0	297	9.6	356	12.0	445	13.2	490
		38	CM B 16 - 038	33.9	9.5	322	11.4	386	14.3	485	17.2	583
		44	CM B 16 - 044	30.0	11.0	330	13.2	396	16.5	495	19.4	582
		51	CM B 16 - 051	26.4	12.8	338	15.3	404	19.1	504	24.2	639
		64	CM B 16 - 064	20.5	16.0	328	19.2	394	24.0	492	29.2	599
		76	CM B 16 - 076	17.8	19.0	338	22.8	406	28.5	507	36.3	646
		89	CM B 16 - 089	15.2	22.3	339	26.7	406	33.4	508	41.7	634
		102	CM B 16 - 102	13.5	25.5	344	30.6	413	38.3	517	48.9	660
		115	CM B 16 - 115	11.8	28.8	340	34.5	407	43.1	509	53.1	627
305	CM B 16 - 305	4.8	76.3	366	91.5	439	114.4	549	141.6	680		
20	10	25	CM B 20 - 025	98.0	6.3	617	7.5	735	9.4	921	10.5	1029
		32	CM B 20 - 032	72.6	8.0	581	9.6	697	12.0	871	13.9	1009
		38	CM B 20 - 038	56.0	9.5	532	11.4	638	14.3	801	16.6	930
		44	CM B 20 - 044	47.5	11.0	523	13.2	627	16.5	784	18.8	893
		51	CM B 20 - 051	41.7	12.8	534	15.3	638	19.1	796	23.1	963
		64	CM B 20 - 064	32.3	16.0	517	19.2	620	24.0	775	27.5	888
		76	CM B 20 - 076	25.1	19.0	477	22.8	572	28.5	715	33.8	848
		89	CM B 20 - 089	22.0	22.3	491	26.7	587	33.4	735	39.7	873
		102	CM B 20 - 102	19.8	25.5	505	30.6	606	38.3	758	47.3	937
		115	CM B 20 - 115	18.1	28.8	521	34.5	624	43.1	780	52.5	950
		127	CM B 20 - 127	16.6	31.8	528	38.1	632	47.6	790	56.9	945
		139	CM B 20 - 139	15.1	35.0	529	42.0	634	52.5	793	62.1	938
		152	CM B 20 - 152	13.2	38.0	500	45.6	600	57.0	750	67.6	889
		305	CM B 20 - 305	6.1	76.3	465	91.5	558	114.4	698	143.4	875
4.1 x 2.4												

Colore blu Blue color Kennfarbe blau Couleur bleu

Filo rettangolare Rectangular wire Reckteckigem drahtquerschnitt Fil rectangulaire

D _H	D _d	L ₀	N. di catalogo Catalogue No. Bestellnummer N° de catalogue	Rigidità Rate Rigidez Raideur	25%		30%		37.5%		D			
					3.000.000	N	1.500.000	N	M aX. Defl.	N	Approx.	N		
x h		mm		N / mm	mm	N	mm	N	mm	N	mm	N		
25	12.5	25	CM B 25 - 025	147	6.3	926	7.5	1103	9.4	1382	10.2	1499		
		32	CM B 25 - 032	118	8.0	944	9.6	1133	12.0	1416	13.7	1617		
		38	CM B 25 - 038	93.0	9.5	884	11.4	1060	14.3	1330	15.7	1460		
		44	CM B 25 - 044	80.8	11.0	889	13.2	1067	16.5	1333	18.2	1471		
		51	CM B 25 - 051	68.6	12.8	878	15.3	1050	19.1	1310	21.7	1489		
		64	CM B 25 - 064	53.0	16.0	848	19.2	1018	24.0	1272	26.0	1378		
		76	CM B 25 - 076	43.2	19.0	821	22.8	985	28.5	1231	32.3	1395		
		89	CM B 25 - 089	38.2	22.3	852	26.7	1020	33.4	1276	38.0	1452		
		102	CM B 25 - 102	33.0	25.5	842	30.6	1010	38.3	1264	43.0	1419		
		115	CM B 25 - 115	28.0	28.8	806	34.5	966	43.1	1207	48.6	1361		
		127	CM B 25 - 127	25.9	31.8	824	38.1	987	47.6	1233	53.7	1391		
		139	CM B 25 - 139	23.2	35.0	812	42.0	974	52.5	1218	59.4	1378		
		152	CM B 25 - 152	20.8	38.0	790	45.6	948	57.0	1186	63.8	1327		
		178	CM B 25 - 178	17.8	44.5	792	53.4	951	66.8	1189	76.6	1363		
5.4 x 3.3		203	CM B 25 - 203	15.8	50.8	803	60.9	962	76.1	1202	88.4	1397		
		305	CM B 25 - 305	10.2	76.3	778	91.5	933	114.4	1167	135.1	1378		
32	16	38	CM B 32 - 038	185	9.5	1758	11.4	2109	14.3	2646	16.3	3016		
		44	CM B 32 - 044	158	11.0	1738	13.2	2086	16.5	2607	18.9	2986		
		51	CM B 32 - 051	134	12.8	1715	15.3	2050	19.1	2559	23.1	3095		
		64	CM B 32 - 064	99.0	16.0	1584	19.2	1901	24.0	2376	28.5	2822		
		76	CM B 32 - 076	80.5	19.0	1530	22.8	1835	28.5	2294	34.2	2753		
		89	CM B 32 - 089	69.1	22.3	1541	26.7	1845	33.4	2308	40.4	2792		
		102	CM B 32 - 102	58.8	25.5	1499	30.6	1799	38.3	2252	48.0	2822		
		115	CM B 32 - 115	51.5	28.8	1483	34.5	1777	43.1	2220	54.3	2796		
		127	CM B 32 - 127	44.8	31.8	1425	38.1	1707	47.6	2132	59.2	2652		
		139	CM B 32 - 139	42.3	35.0	1481	42.0	1777	52.5	2221	65.3	2762		
		152	CM B 32 - 152	37.8	38.0	1436	45.6	1724	57.0	2155	73.0	2759		
		178	CM B 32 - 178	32.5	44.5	1446	53.4	1736	66.8	2171	84.5	2746		
		203	CM B 32 - 203	28.9	50.8	1468	60.9	1760	76.1	2199	96.9	2800		
		6.8 x 4.0		254	CM B 32 - 254	21.4	63.5	1359	76.2	1631	95.3	2039	120.9	2587
		305	CM B 32 - 305	18.3	76.3	1396	91.5	1674	114.4	2094	146.9	2688		
40	20	51	CM B 40 - 051	181.6	12.8	2324	15.3	2778	19.1	3469	21.4	3886		
		64	CM B 40 - 064	140.0	16.0	2240	19.2	2688	24.0	3360	26.8	3752		
		76	CM B 40 - 076	108.0	19.0	2052	22.8	2462	28.5	3078	32.7	3532		
		89	CM B 40 - 089	90.7	22.3	2023	26.7	2422	33.4	3029	39.0	3537		
		102	CM B 40 - 102	81.0	25.5	2066	30.6	2479	38.3	3102	44.1	3572		
		115	CM B 40 - 115	71.8	28.8	2068	34.5	2477	43.1	3095	50.6	3633		
		127	CM B 40 - 127	62.7	31.8	1994	38.1	2389	47.6	2985	55.9	3505		
		139	CM B 40 - 139	57.5	35.0	2013	42.0	2415	52.5	3019	61.8	3554		
		152	CM B 40 - 152	51.6	38.0	1961	45.6	2353	57.0	2941	67.5	3483		
		178	CM B 40 - 178	44.1	44.5	1962	53.4	2355	66.8	2946	77.2	3405		
		203	CM B 40 - 203	36.7	50.8	1864	60.9	2235	76.1	2793	91.8	3369		
		8.2 x 4.7		254	CM B 40 - 254	30.1	63.5	1911	76.2	2294	95.3	2869	112.7	3392
				305	CM B 40 - 305	24.6	76.3	1877	91.5	2251	114.4	2814	138.1	3397
		50	25	64	CM B 50 - 064	209	16.0	3344	19.2	4013	24.0	5016	28.2	5894
76	CM B 50 - 076			168	19.0	3192	22.8	3830	28.5	4788	34.9	5863		
89	CM B 50 - 089			140	22.3	3122	26.7	3738	33.4	4676	39.2	5488		
102	CM B 50 - 102			119	25.5	3035	30.6	3641	38.3	4558	47.3	5629		
115	CM B 50 - 115			106	28.8	3053	34.5	3657	43.1	4569	52.6	5576		
127	CM B 50 - 127			97.0	31.8	3085	38.1	3696	47.6	4617	59.8	5801		
139	CM B 50 - 139			87.0	35.0	3045	42.0	3654	52.5	4568	65.1	5664		
152	CM B 50 - 152			80.0	38.0	3040	45.6	3648	57.0	4560	70.8	5664		
178	CM B 50 - 178			69.5	44.5	3093	53.4	3711	66.8	4643	84.2	5852		
203	CM B 50 - 203			59.8	50.8	3038	60.9	3642	76.1	4551	96.5	5771		
229	CM B 50 - 229			50.9	57.3	2917	68.7	3497	85.9	4372	108.5	5523		
11.1 x 5.8				254	CM B 50 - 254	43.9	63.5	2788	76.2	3345	95.3	4184	121.8	5347
				305	CM B 50 - 305	38.6	76.3	2945	91.5	3532	114.4	4416	146.8	5666
63	38			76	CM B 63 - 076	312	19.0	5928	22.8	7114	28.5	8892	30.7	9578
		89	CM B 63 - 089	260	22.3	5798	26.7	6942	33.4	8684	36.5	9490		
		102	CM B 63 - 102	221	25.5	5636	30.6	6763	38.3	8464	43.6	9636		
		115	CM B 63 - 115	187	28.8	5386	34.5	6452	43.1	8060	48.9	9144		
		127	CM B 63 - 127	168	31.8	5342	38.1	6401	47.6	7997	54.2	9106		
		152	CM B 63 - 152	136	38.0	5168	45.6	6202	57.0	7752	65.7	8935		
		178	CM B 63 - 178	114	44.5	5073	53.4	6088	66.8	7615	76.5	8721		
		203	CM B 63 - 203	100	50.8	5080	60.9	6090	76.1	7610	88.0	8800		
		229	CM B 63 - 229	89.2	57.3	5111	68.7	6128	85.9	7662	103.9	9268		
		254	CM B 63 - 254	78.4	63.5	4978	76.2	5974	95.3	7472	112.4	8812		
		11.5 x 9.1		305	CM B 63 - 305	64.7	76.3	4937	91.5	5920	114.4	7402	133.8	8657

Molle carico forte
Heavy load springs
Federn für hohe belastung
Ressorts charge forte

Serie Series Serie Série CFR

ISO 10243

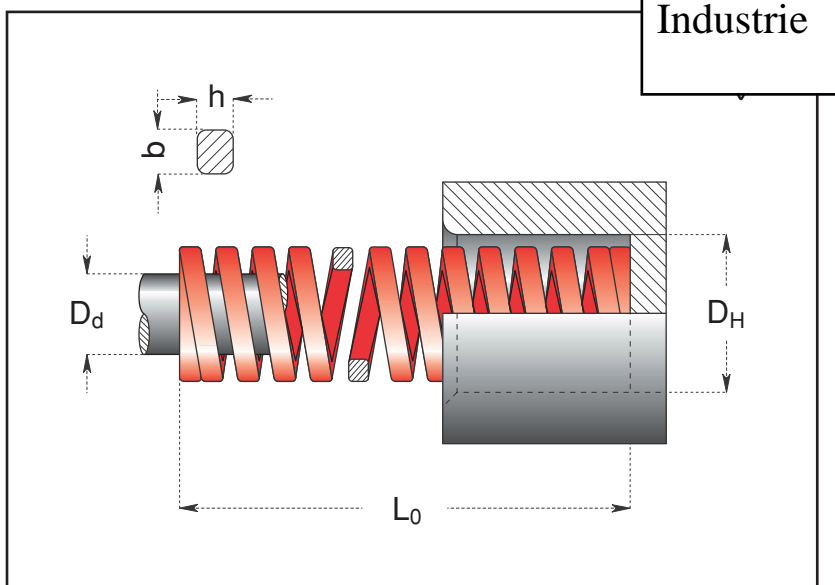

D_H	D_d	L_0	N. di catalogo Catalogue No. Bestellnummer N° de catalogue	Rigidità Rate Rigidez Raideur	20%		25%		30%		D	
					3.000.000	1.500.000	M aX. Defl.	Approx.				
x h				N / mm	mm	N	mm	N	mm	N	mm	N
mm	mm	mm										
10	5	25	CFR 10 - 025	22.1	5.0	111	6.3	139	7.5	166	9.2	203
		32	CFR 10 - 032	17.5	6.4	112	8.0	140	9.6	168	12.1	212
		38	CFR 10 - 038	17.1	7.6	130	9.5	162	11.4	195	13.2	226
		44	CFR 10 - 044	15.0	8.8	132	11.0	165	13.2	198	15.1	227
		51	CFR 10 - 051	12.8	10.2	131	12.8	164	15.3	196	19.5	250
		64	CFR 10 - 064	10.7	12.8	137	16.0	171	19.2	205	21.8	233
		76	CFR 10 - 076	7.5	15.2	114	19.0	143	22.8	171	27.9	209
		305	CFR 10 - 305	2.1	61.0	128	76.3	160	91.5	192	127.2	267
12.5	6.3	25	CFR 13 - 025	42.1	5.0	211	6.3	265	7.5	316	9.8	413
		32	CFR 13 - 032	33.2	6.4	212	8.0	266	9.6	319	13.6	452
		38	CFR 13 - 038	29.3	7.6	223	9.5	278	11.4	334	14.6	428
		44	CFR 13 - 044	24.6	8.8	216	11.0	271	13.2	325	18.1	445
		51	CFR 13 - 051	19.6	10.2	200	12.8	251	15.3	300	22.3	437
		64	CFR 13 - 064	15.0	12.8	192	16.0	240	19.2	288	27.3	410
		76	CFR 13 - 076	13.2	15.2	201	19.0	251	22.8	301	33.1	437
		89	CFR 13 - 089	11.4	17.8	203	22.3	254	26.7	304	38.9	443
		102	CFR 13 - 102	8.4	20.4	171	25.5	214	30.6	257	43.8	368
		305	CFR 13 - 305	2.8	61.0	171	76.3	214	91.5	256	139.7	391
16	8	25	CFR 16 - 025	75.7	5.0	379	6.3	477	7.5	568	8.4	636
		32	CFR 16 - 032	52.8	6.4	338	8.0	422	9.6	507	10.5	554
		38	CFR 16 - 038	48.5	7.6	369	9.5	461	11.4	553	13.6	660
		44	CFR 16 - 044	42.8	8.8	377	11.0	471	13.2	565	15.9	681
		51	CFR 16 - 051	37.1	10.2	378	12.8	475	15.3	568	18.9	701
		64	CFR 16 - 064	30.3	12.8	388	16.0	485	19.2	582	24.9	754
		76	CFR 16 - 076	25.7	15.2	391	19.0	488	22.8	586	29.2	750
		89	CFR 16 - 089	21.7	17.8	386	22.3	484	26.7	579	34.5	749
		102	CFR 16 - 102	19.3	20.4	394	25.5	492	30.6	591	39.1	755
		115	CFR 16 - 115	15.7	23.0	361	28.8	452	34.5	542	44.0	691
		305	CFR 16 - 305	7.1	61.0	433	76.3	542	91.5	650	103.6	736
20	10	25	CFR 20 - 025	216	5.0	1080	6.3	1361	7.5	1620	8.3	1793
		32	CFR 20 - 032	168	6.4	1075	8.0	1344	9.6	1613	10.9	1831
		38	CFR 20 - 038	129	7.6	980	9.5	1226	11.4	1471	12.5	1613
		44	CFR 20 - 044	112	8.8	986	11.0	1232	13.2	1478	15.0	1680
		51	CFR 20 - 051	94.0	10.2	959	12.8	1203	15.3	1438	17.6	1654
		64	CFR 20 - 064	72.1	12.8	923	16.0	1154	19.2	1384	22.6	1629
		76	CFR 20 - 076	59.7	15.2	907	19.0	1134	22.8	1361	27.5	1642
		89	CFR 20 - 089	50.5	17.8	899	22.3	1126	26.7	1348	31.7	1601
		102	CFR 20 - 102	44.2	20.4	902	25.5	1127	30.6	1353	37.5	1658
		115	CFR 20 - 115	38.4	23.0	883	28.8	1106	34.5	1325	42.6	1636
		127	CFR 20 - 127	34.1	25.4	866	31.8	1084	38.1	1299	45.5	1552
		139	CFR 20 - 139	31.0	28.0	868	35.0	1085	42.0	1302	50.1	1553
		152	CFR 20 - 152	28.2	30.4	857	38.0	1072	45.6	1286	55.8	1574
		305	CFR 20 - 305	15.0	61.0	915	76.3	1145	91.5	1373	114.1	1712
		4.0 x 3.3										

Colore rosso Red color Kennfarbe rot Couleur rouge

Filo rettangolare Rectangular wire Reckteckigem drahtquerschnitt Fil rectangulaire

D _H	D _d	L ₀	N. di catalogo Catalogue No. Bestellnummer N° de catalogue	Rigidità Rate Rigidez Raideur	20%		25%		30%		D			
					3.000.000		1.500.000		M aX. Defl.		Approx.			
x h		mm		N / mm	mm	N	mm	N	mm	N	mm	N		
25	12.5	25	CFR 25 - 025	375	5.0	1875	6.3	2363	7.5	2813	8.5	3188		
		32	CFR 25 - 032	297	6.4	1901	8.0	2376	9.6	2851	11.0	3267		
		38	CFR 25 - 038	219	7.6	1664	9.5	2081	11.4	2497	12.6	2759		
		44	CFR 25 - 044	187	8.8	1646	11.0	2057	13.2	2468	14.8	2768		
		51	CFR 25 - 051	156	10.2	1591	12.8	1997	15.3	2387	17.9	2792		
		64	CFR 25 - 064	123	12.8	1574	16.0	1968	19.2	2362	23.1	2841		
		76	CFR 25 - 076	99.0	15.2	1505	19.0	1881	22.8	2257	26.3	2604		
		89	CFR 25 - 089	84.0	17.8	1495	22.3	1873	26.7	2243	30.5	2562		
		102	CFR 25 - 102	73.0	20.4	1489	25.5	1862	30.6	2234	37.3	2723		
		115	CFR 25 - 115	65.0	23.0	1495	28.8	1872	34.5	2243	41.9	2724		
		127	CFR 25 - 127	57.7	25.4	1466	31.8	1835	38.1	2198	46.2	2666		
		139	CFR 25 - 139	52.7	28.0	1476	35.0	1845	42.0	2213	49.3	2598		
		152	CFR 25 - 152	47.8	30.4	1453	38.0	1816	45.6	2180	55.7	2662		
		178	CFR 25 - 178	41.0	35.6	1460	44.5	1825	53.4	2189	65.1	2669		
5.5 x 4.2		203	CFR 25 - 203	35.8	40.6	1453	50.8	1819	60.9	2180	74.5	2667		
		305	CFR 25 - 305	22.9	61.0	1397	76.3	1747	91.5	2095	110.2	2524		
32	16	38	CFR 32 - 038	388	7.6	2949	9.5	3686	11.4	4423	12.5	4850		
		44	CFR 32 - 044	324	8.8	2851	11.0	3564	13.2	4277	14.9	4828		
		51	CFR 32 - 051	272	10.2	2774	12.8	3482	15.3	4162	17.8	4842		
		64	CFR 32 - 064	212	12.8	2714	16.0	3392	19.2	4070	22.4	4749		
		76	CFR 32 - 076	172	15.2	2614	19.0	3268	22.8	3922	26.1	4489		
		89	CFR 32 - 089	141	17.8	2510	22.3	3144	26.7	3765	30.8	4343		
		102	CFR 32 - 102	122	20.4	2489	25.5	3111	30.6	3733	36.8	4490		
		115	CFR 32 - 115	107	23.0	2461	28.8	3082	34.5	3692	41.4	4430		
		127	CFR 32 - 127	93.0	25.4	2362	31.8	2957	38.1	3543	44.4	4129		
		139	CFR 32 - 139	86.0	28.0	2408	35.0	3010	42.0	3612	48.5	4171		
		152	CFR 32 - 152	78.0	30.4	2371	38.0	2964	45.6	3557	54.8	4274		
		178	CFR 32 - 178	67.2	35.6	2392	44.5	2990	53.4	3588	63.6	4274		
		203	CFR 32 - 203	59.1	40.6	2399	50.8	3002	60.9	3599	72.5	4285		
		7.1 x 5.4		254	CFR 32 - 254	46.4	50.8	2357	63.5	2946	76.2	3536	92.8	4306
		305	CFR 32 - 305	38.0	61.0	2318	76.3	2899	91.5	3477	111.8	4248		
40	20	51	CFR 40 - 051	350	10.2	3570	12.8	4480	15.3	5355	17.0	5950		
		64	CFR 40 - 064	269	12.8	3443	16.0	4304	19.2	5165	21.9	5891		
		76	CFR 40 - 076	219	15.2	3329	19.0	4161	22.8	4993	26.7	5847		
		89	CFR 40 - 089	190	17.8	3382	22.3	4237	26.7	5073	31.3	5947		
		102	CFR 40 - 102	163	20.4	3325	25.5	4157	30.6	4988	37.1	6047		
		115	CFR 40 - 115	142	23.0	3266	28.8	4090	34.5	4899	41.0	5822		
		127	CFR 40 - 127	128	25.4	3251	31.8	4070	38.1	4877	46.5	5952		
		139	CFR 40 - 139	115	28.0	3220	35.0	4025	42.0	4830	53.1	6107		
		152	CFR 40 - 152	105	30.4	3192	38.0	3990	45.6	4788	56.1	5891		
		178	CFR 40 - 178	89	35.6	3168	44.5	3961	53.4	4753	67.4	5999		
		203	CFR 40 - 203	77	40.6	3126	50.8	3912	60.9	4689	76.2	5867		
		254	CFR 40 - 254	61	50.8	3099	63.5	3874	76.2	4648	96.2	5868		
		8.4 x 6.2		305	CFR 40 - 305	51	61.0	3111	76.3	3891	91.5	4667	114.8	5855
		50	25	64	CFR 50 - 064	413	12.8	5286	16.0	6608	19.2	7930	22.4	9251
76	CFR 50 - 076			339	15.2	5153	19.0	6441	22.8	7729	26.5	8984		
89	CFR 50 - 089			288	17.8	5126	22.3	6422	26.7	7690	31.5	9072		
102	CFR 50 - 102			245	20.4	4998	25.5	6248	30.6	7497	37.6	9212		
115	CFR 50 - 115			215	23.0	4945	28.8	6192	34.5	7418	42.7	9181		
127	CFR 50 - 127			192	25.4	4877	31.8	6106	38.1	7315	47.5	9120		
139	CFR 50 - 139			168	28.0	4704	35.0	5880	42.0	7056	51.8	8702		
152	CFR 50 - 152			154	30.4	4682	38.0	5852	45.6	7022	57.8	8901		
178	CFR 50 - 178			134	35.6	4770	44.5	5963	53.4	7156	68.5	9179		
203	CFR 50 - 203			117	40.6	4750	50.8	5944	60.9	7125	77.6	9079		
254	CFR 50 - 254			89	50.8	4521	63.5	5652	76.2	6782	97.9	8713		
11.1 x 7.6				305	CFR 50 - 305	73	61.0	4453	76.3	5570	91.5	6680	120.7	8811
63	38			76	CFR 63 - 076	618	15.2	9394	19.0	11742	22.8	14090	24.7	15265
				89	CFR 63 - 089	515	17.8	9167	22.3	11485	26.7	13751	30.0	15450
		102	CFR 63 - 102	438	20.4	8935	25.5	11169	30.6	13403	35.1	15374		
		115	CFR 63 - 115	370	23.0	8510	28.8	10656	34.5	12765	37.5	13875		
		127	CFR 63 - 127	333	25.4	8458	31.8	10589	38.1	12687	45.9	15285		
		152	CFR 63 - 152	269	30.4	8178	38.0	10222	45.6	12266	56.5	15199		
		178	CFR 63 - 178	226	35.6	8046	44.5	10057	53.4	12068	66.8	15097		
		203	CFR 63 - 203	198	40.6	8039	50.8	10058	60.9	12058	78.8	15602		
		254	CFR 63 - 254	155	50.8	7874	63.5	9843	76.2	11811	101.7	15763		
		11.6 x 12.3		305	CFR 63 - 305	128	61.0	7808	76.3	9766	91.5	11712	122.4	15667

Molle carico extra-forte
Extra-heavy load springs
Federn für höchste belastung
Ressorts charge extra-forte

Serie Series Serie Série **CXF**

ISO 10243

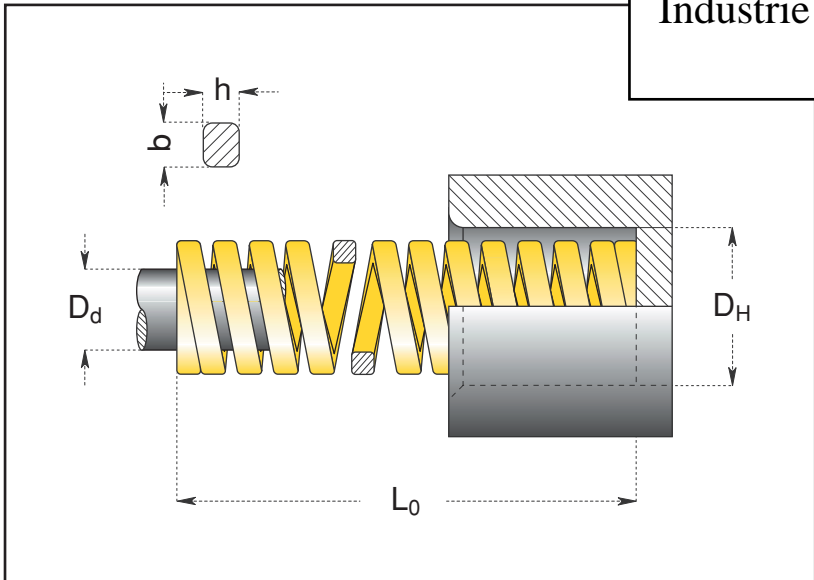

D _H	D _d	L ₀	N. di catalogo Catalogue No. Bestellnummer N° de catalogue	Rigidità Rate Rigidez Raideur	17%		20%		25%		D	
					3.000.000		1.500.000		M aX. Defl.		Approx.	
x h				N / mm	mm	N	mm	N	mm	N	mm	N
mm	mm	mm										
10	5	25	CXF 10 - 025	36.8	4.3	158	5.0	184	6.3	232	7.7	283
		32	CXF 10 - 032	27.9	5.4	151	6.4	179	8.0	223	10.6	296
		38	CXF 10 - 038	23.7	6.5	154	7.6	180	9.5	225	12.6	299
		44	CXF 10 - 044	19.2	7.5	144	8.8	169	11.0	211	13.8	265
		51	CXF 10 - 051	16.5	8.7	144	10.2	168	12.8	211	16.2	267
		64	CXF 10 - 064	13.2	10.9	144	12.8	169	16.0	211	20.4	269
		76	CXF 10 - 076	10.9	12.9	141	15.2	166	19.0	207	25.2	275
		305	CXF 10 - 305	2.6	51.9	135	61.0	159	76.3	198	110.8	288
12.5	6.3	25	CXF 13 - 025	58.5	4.3	252	5.0	293	6.3	369	8.1	474
		32	CXF 13 - 032	43.9	5.4	237	6.4	281	8.0	351	9.9	435
		38	CXF 13 - 038	36.0	6.5	234	7.6	274	9.5	342	12.9	464
		44	CXF 13 - 044	30.3	7.5	227	8.8	267	11.0	333	14.1	427
		51	CXF 13 - 051	26.2	8.7	228	10.2	267	12.8	335	17.4	456
		64	CXF 13 - 064	21.2	10.9	231	12.8	271	16.0	339	21.0	445
		76	CXF 13 - 076	17.1	12.9	221	15.2	260	19.0	325	26.4	451
		89	CXF 13 - 089	14.5	15.1	219	17.8	258	22.3	323	31.5	457
		102	CXF 13 - 102	12.7	17.3	220	20.4	259	25.5	324	36.0	457
		305	CXF 13 - 305	4.3	51.9	223	61.0	262	76.3	328	111.3	479
16	8	25	CXF 16 - 025	118	4.3	507	5.0	590	6.3	743	8.5	1003
		32	CXF 16 - 032	89.0	5.4	481	6.4	570	8.0	712	11.0	979
		38	CXF 16 - 038	72.1	6.5	469	7.6	548	9.5	685	13.2	952
		44	CXF 16 - 044	60.9	7.5	457	8.8	536	11.0	670	14.7	895
		51	CXF 16 - 051	52.3	8.7	455	10.2	533	12.8	669	17.7	926
		64	CXF 16 - 064	41.2	10.9	449	12.8	527	16.0	659	21.9	902
		76	CXF 16 - 076	34.1	12.9	440	15.2	518	19.0	648	27.8	948
		89	CXF 16 - 089	29.5	15.1	445	17.8	525	22.3	658	31.2	920
		102	CXF 16 - 102	25.6	17.3	443	20.4	522	25.5	653	37.9	970
		115	CXF 16 - 115	22.4	19.6	439	23.0	515	28.8	645	44.5	997
		305	CXF 16 - 305	8.4	51.9	436	61.0	512	76.3	641	113.5	953
20	10	25	CXF 20 - 025	293	4.3	1260	5.0	1465	6.3	1846	6.9	2022
		32	CXF 20 - 032	224	5.4	1210	6.4	1434	8.0	1792	9.4	2106
		38	CXF 20 - 038	177	6.5	1151	7.6	1345	9.5	1682	12.0	2124
		44	CXF 20 - 044	149	7.5	1118	8.8	1311	11.0	1639	13.5	2012
		51	CXF 20 - 051	128	8.7	1114	10.2	1306	12.8	1638	16.2	2074
		64	CXF 20 - 064	99.0	10.9	1079	12.8	1267	16.0	1584	21.2	2099
		76	CXF 20 - 076	81.7	12.9	1054	15.2	1242	19.0	1552	24.7	2018
		89	CXF 20 - 089	69.5	15.1	1049	17.8	1237	22.3	1550	28.8	2002
		102	CXF 20 - 102	60.6	17.3	1048	20.4	1236	25.5	1545	34.8	2109
		115	CXF 20 - 115	53.0	19.6	1039	23.0	1219	28.8	1526	39.0	2067
		127	CXF 20 - 127	47.5	21.6	1026	25.4	1207	31.8	1511	43.0	2043
		139	CXF 20 - 139	43.0	23.8	1023	28.0	1204	35.0	1505	45.3	1948
		152	CXF 20 - 152	39.0	25.8	1006	30.4	1186	38.0	1482	50.4	1966
		305	CXF 20 - 305	21.2	51.9	1100	61.0	1293	76.3	1618	103.5	2194
4.1 x 3.8												

Colore giallo Yellow color Kennfarbe gelb Couleur jaune

Filo rettangolare Rectangular wire Reckteckigem drahtquerschnitt Fil rectangulaire

D _H	D _d	L ₀	N. di catalogo Catalogue No. Bestellnummer N° de catalogue	Rigidità Rate Rigidez Raideur	17%		20%		25%		D			
					3.000.000		1.500.000		M aX. Defl.		Approx.			
b x h														
mm	mm	mm		N /mm	mm	N	mm	N	mm	N	mm	N		
25	12.5	25	CXF 25 - 025	459.0	4.3	1974	5.0	2295	6.3	2892	7.3	3351		
		32	CXF 25 - 032	374.4	5.4	2022	6.4	2396	8.0	2995	10.7	4006		
		38	CXF 25 - 038	346.0	6.5	2249	7.6	2630	9.5	3287	12.0	4152		
		44	CXF 25 - 044	244.0	7.5	1830	8.8	2147	11.0	2684	14.4	3514		
		51	CXF 25 - 051	207.5	8.7	1805	10.2	2117	12.8	2656	17.4	3611		
		64	CXF 25 - 064	161.0	10.9	1755	12.8	2061	16.0	2576	21.4	3445		
		76	CXF 25 - 076	130.8	12.9	1687	15.2	1988	19.0	2485	26.9	3519		
		89	CXF 25 - 089	110.5	15.1	1669	17.8	1967	22.3	2464	30.9	3414		
		102	CXF 25 - 102	96.3	17.3	1666	20.4	1965	25.5	2456	36.7	3534		
		115	CXF 25 - 115	85.7	19.6	1680	23.0	1971	28.8	2468	40.3	3454		
		127	CXF 25 - 127	76.3	21.6	1648	25.4	1938	31.8	2426	45.1	3441		
		139	CXF 25 - 139	68.9	23.8	1640	28.0	1929	35.0	2412	47.6	3280		
		152	CXF 25 - 152	63.5	25.8	1638	30.4	1930	38.0	2413	53.5	3397		
		178	CXF 25 - 178	53.9	30.3	1633	35.6	1919	44.5	2399	63.9	3444		
5.4 x 4.6		203	CXF 25 - 203	47.0	34.5	1622	40.6	1908	50.8	2388	70.2	3299		
		305	CXF 25 - 305	30.9	51.9	1604	61.0	1885	76.3	2358	110.1	3402		
32	16	38	CXF 32 - 038	528.2	6.5	3433	7.6	4014	9.5	5018	11.4	6021		
		44	CXF 32 - 044	424.4	7.5	3183	8.8	3735	11.0	4668	13.7	5814		
		51	CXF 32 - 051	353.0	8.7	3071	10.2	3601	12.8	4518	15.6	5507		
		64	CXF 32 - 064	269.2	10.9	2934	12.8	3446	16.0	4307	20.0	5384		
		76	CXF 32 - 076	218.5	12.9	2819	15.2	3321	19.0	4152	24.4	5331		
		89	CXF 32 - 089	180.3	15.1	2723	17.8	3209	22.3	4021	29.7	5355		
		102	CXF 32 - 102	155.0	17.3	2682	20.4	3162	25.5	3953	35.1	5441		
		115	CXF 32 - 115	140.0	19.6	2744	23.0	3220	28.8	4032	39.0	5460		
		127	CXF 32 - 127	124.0	21.6	2678	25.4	3150	31.8	3943	42.8	5307		
		139	CXF 32 - 139	112.3	23.8	2673	28.0	3144	35.0	3931	48.6	5458		
		152	CXF 32 - 152	102.0	25.8	2632	30.4	3101	38.0	3876	52.4	5345		
		178	CXF 32 - 178	88.2	30.3	2672	35.6	3140	44.5	3925	60.9	5371		
		7.3 x 5.9		203	CXF 32 - 203	76.0	34.5	2622	40.6	3086	50.8	3861	69.2	5259
				254	CXF 32 - 254	60.8	43.2	2627	50.8	3089	63.5	3861	88.1	5356
		305	CXF 32 - 305	49.0	51.9	2543	61.0	2989	76.3	3739	104.2	5106		
40	20	51	CXF 40 - 051	628	8.7	5464	10.2	6406	12.8	8038	15.0	9420		
		64	CXF 40 - 064	487	10.9	5308	12.8	6234	16.0	7792	19.5	9497		
		76	CXF 40 - 076	379	12.9	4889	15.2	5761	19.0	7201	23.3	8831		
		89	CXF 40 - 089	321	15.1	4847	17.8	5714	22.3	7158	26.7	8571		
		102	CXF 40 - 102	281	17.3	4861	20.4	5732	25.5	7166	33.8	9498		
		115	CXF 40 - 115	245	19.6	4802	23.0	5635	28.8	7056	36.2	8869		
		127	CXF 40 - 127	221	21.6	4774	25.4	5613	31.8	7028	40.7	8995		
		139	CXF 40 - 139	190	23.8	4522	28.0	5320	35.0	6650	44.5	8455		
		152	CXF 40 - 152	168	25.8	4334	30.4	5107	38.0	6384	49.6	8333		
		178	CXF 40 - 178	146	30.3	4424	35.6	5198	44.5	6497	59.9	8745		
		8.4 x 7.5		203	CXF 40 - 203	132	34.5	4554	40.6	5359	50.8	6706	67.1	8857
				254	CXF 40 - 254	107	43.2	4622	50.8	5436	63.5	6795	86.3	9234
				305	CXF 40 - 305	87.8	51.9	4557	61.0	5356	76.3	6699	103.6	9096
		50	25	64	CXF 50 - 064	709	10.9	7728	12.8	9075	16.0	11344	19.3	13684
76	CXF 50 - 076			572	12.9	7379	15.2	8694	19.0	10868	24.2	13842		
89	CXF 50 - 089			475	15.1	7173	17.8	8455	22.3	10593	28.0	13300		
102	CXF 50 - 102			405	17.3	7007	20.4	8262	25.5	10328	33.5	13568		
115	CXF 50 - 115			352	19.6	6899	23.0	8096	28.8	10138	38.6	13587		
127	CXF 50 - 127			316	21.6	6826	25.4	8026	31.8	10049	41.4	13082		
139	CXF 50 - 139			274	23.8	6521	28.0	7672	35.0	9590	47.3	12960		
152	CXF 50 - 152			239	25.8	6166	30.4	7266	38.0	9082	50.2	11998		
178	CXF 50 - 178			215	30.3	6515	35.6	7654	44.5	9568	61.1	13137		
11.5 x 9.0				203	CXF 50 - 203	187	34.5	6452	40.6	7592	50.8	9500	67.7	12660
				254	CXF 50 - 254	153	43.2	6610	50.8	7772	63.5	9716	87.0	13311
				305	CXF 50 - 305	127	51.9	6591	61.0	7747	76.3	9690	103.4	13132
63	38			76	CXF 63 - 076	952	12.9	12280	15.2	14470	*	*	15.5	14756
				89	CXF 63 - 089	819	15.1	12360	17.8	14580	*	*	20.0	19040
		102	CXF 63 - 102	700	17.3	12110	20.4	14280	25.5	17850	30.7	21449		
		115	CXF 63 - 115	620	19.6	12152	23.0	14260	28.8	17860	34.9	21640		
		127	CXF 63 - 127	565	21.6	12204	25.4	14351	31.8	17967	38.0	21470		
		152	CXF 63 - 152	458	25.8	11816	30.4	13923	38.0	17404	47.2	21618		
		178	CXF 63 - 178	384	30.3	11635	35.6	13670	44.5	17088	55.8	21427		
		203	CXF 63 - 203	337	34.5	11627	40.6	13682	50.8	17120	64.8	21838		
		254	CXF 63 - 254	263	43.2	11362	50.8	13360	63.5	16701	86.7	22802		
		11.6 x 14.9		305	CXF 63 - 305	218	51.9	11314	61.0	13298	76.3	16633	105.7	23043

Barre tonde in poliuretano
Polyurethan springs
Ressort en poliuretano
Schraubenfeder Poliuretano

bmindustrie

BM
Industrie

D	D1	L
16	6,50	500
20	8,50	500
25	10,50	500
32	13,50	500
40	13,50	500
50	17	500
63	17	500
80	21	500
100	21	500
125	27	500

Verde SH.80
 Green SH.80
 Vert SH.80
 Grün SH.80

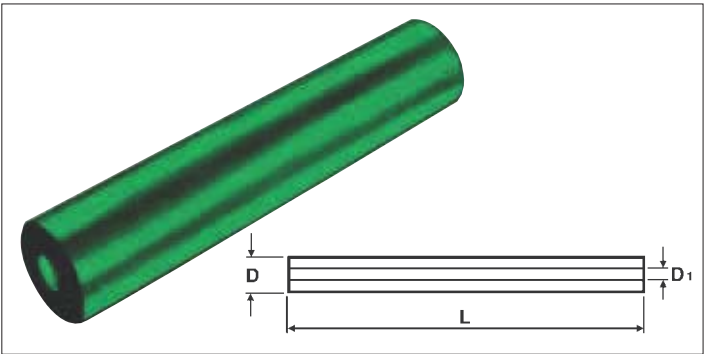

Massimo schiacciamento 30% della lunghezza libera
 Max deflection 30% of the free length

D	D1	L
16	6,50	500
20	8,50	500
25	10,50	500
32	13,50	500
40	13,50	500
50	17	500
63	17	500
80	21	500
100	21	500
125	27	500

Rosso SH. 90
 Red SH. 90
 Rouge SH. 90
 Rot SH. 90

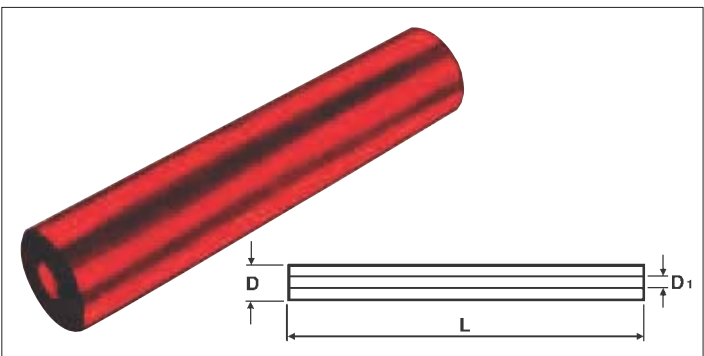

Massimo schiacciamento 25% della lunghezza libera
 Max deflection 25% of the free length

D	D1	L
16	6,50	500
20	8,50	500
25	10,50	500
32	13,50	500
40	13,50	500
50	17	500
63	17	500
80	21	500
100	21	500
125	27	500

Giallo SH.95
 Yellow SH.95
 Jaune SH.95
 Gelb SH.95

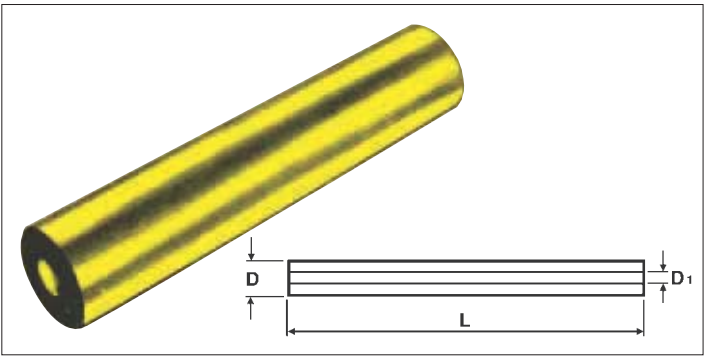

Massimo schiacciamento 20% della lunghezza libera
 Max deflection 20% of the free length

A richiesta Barre piene - Full bars on request

**Barre tonde forate “Retflex”
Polyurethan springs “Retflex”
Ressortes en poliuretano “Retflex”
Poliuretano Federn “Retflex”**

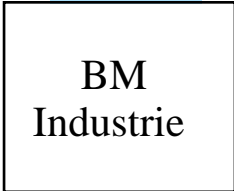

Quando da queste barre si ricavano molle per stampi, l'altezza non deve essere mai maggiore del doppio del diametro D.
When bars are to be cut to obtain die springs, the height should never exceed twice the diameter (D) height.

Nei casi di alloggiamento nelle piastre lasciare spazio per il rigonfiamento.
When springs are to be housed in the plates, sufficient space is to be left for the expansion.

È intaccabile dagli oli, idrocarburi.
It cannot be damaged by oils and hydrocarbons.

Temperatura max di esercizio 80°C.
Max. operating temperature 80°C.

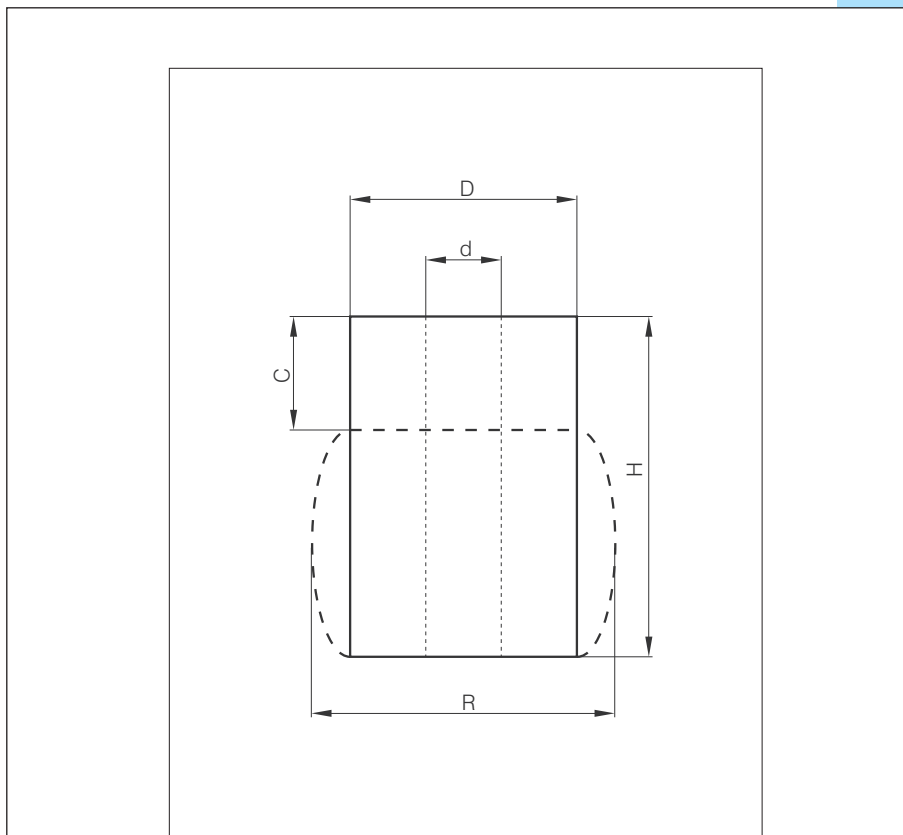

C Com ressione massima de a mo a com rensi a de a recarica.
ax. s ring com ression, inc usi e of re oading.

R Diametro di rigonfiamento de a mo a a massima com ressione.
S ring ex ansion diameter under the max. com ression.

H A t. i era de a mo a.
S ring free height.

Le di erse durezze sono contraddistinte da di ersi co ori
Different hardnesses are mar ed different co ours.

GIALLO / YELLOW 80 Sh

ARANCIO / ORANGE 90 Sh

OCRA / OCHRE 95 Sh

COM PRESSIONE MAX.	80 SH A	35%	90 SH A	30%	95 SH A	25%				
BARRE FORATE TONDE										
ø esterno D	16	20	25	32	40	50	63	80	100	125
ø interno d	6,50	8,50	10,50	13,50	13,50	17	17	21	21	27
Lunghezza L	250	250	250	500	500	500	500	500	500	500

A richiesta si possono fare pezzi non unificati.
Non-standard parts can be made on request

Barre forate in poliuretano “Retflex”
Polyurethan springs “Retflex”
Ressortes en poliuretano “Retflex”
Poliuretano Federn “Retflex”

**BM
Industrie**

Molle forate a lunghezza unificate											
Durezza			80 SH A			90 SH A5			95 SH A		
Compressione max.			35%			30%			25%		
D	d	H	C	R	kp	C	R	kp	C	R	kp
16	6,5	16	5,6	21	50	4,8	20	130	4	19	200
		20	7			6			5		
		25	8,7			7,5			6,2		
		32	11,2			9,6			8		
20	8,5	16	5,6	28	100	4,8	27	200	4	25	340
		20	7			6			5		
		25	8,7			7,5			6,2		
		32	11,2			9,6			8		
25	10,5	16	5,6	35	190	4,8	32	340	4	30	500
		20	7			6			5		
		25	8,7			7,5			6,2		
		32	11,2			9,6			8		
32	13,5	16	5,6	42	250	4,8	39	500	4	38	800
		20	7			6			5		
		25	8,7			7,5			6,2		
		32	11,2			9,6			8		
40	13,5	40	14	52	450	12	49	800	10	46	1300
		50	17,5			15			12,5		
		63	22			19			15,7		
		80	28			24			20		
50	17	25	8,7	66	900	7,5	62	1700	6,2	59	2100
		32	11,2			9,6			8		
		40	14			12			10		
		50	17,5			15			12,5		
63	17	63	22	80	1300	19	79	2200	15,7	75	3500
		80	28			24			20		
		100	35			30			25		
		125	43,7			37,5			31,2		
80	21	40	14	105	210	12	102	4500	10	98	700
		50	17,5			15			12,5		
		63	22			19			15,7		
		80	28			24			20		
100	21	100	35	127	4000	30	125	7700	25	121	10700
		125	43,7			37,5			31,2		
		160	56			48			40		
		200	70			60			50		
125	27	50	17	175	5500	15	170	8000	12	160	1200
		63	22			19			15		
		80	28			24			20		
		100	35			30			25		
		125	43			37			31		
		160	56			48			40		

A richiesta si possono fare pezzi non unificati.

Non-standard parts can be made on request

Diagramma di carico Molle Retflex
Load diagram for Retflex Springs
Diagramme de charge pour Ressortes Retflex

BM
Industrie

80 Sh
Giallo
Yellow
Jaune
Gelb

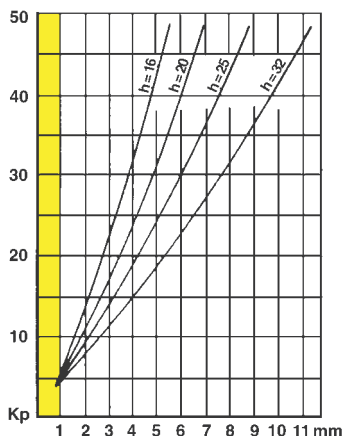

ø 16 - 80 SH
 35% di compres. max

90 Sh
Arancio
Orange
Orange
Orange

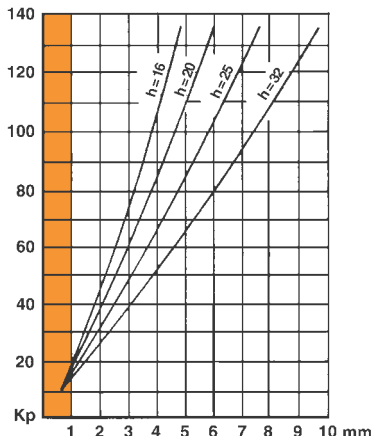

ø 16 - 90 SH
 30% di compres. max

95 Sh
Ocra
Ochre
Ochre
Ocker

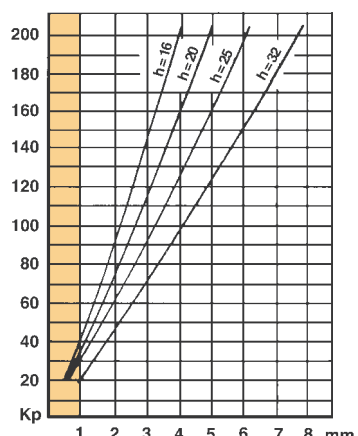

ø 16 - 95 SH
 25% di compres. max

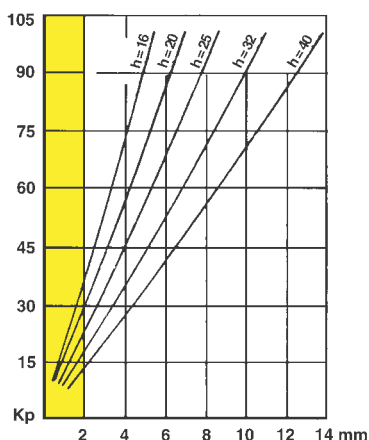

ø 20 - 80 SH
 35% di compres. max

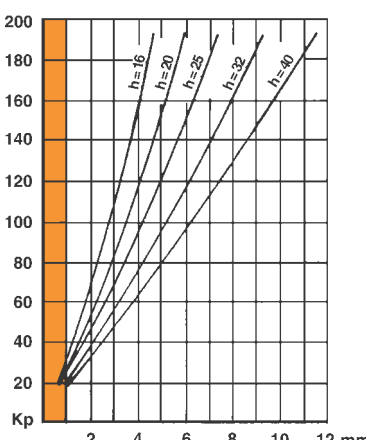

ø 20 - 90 SH
 30% di compres. max

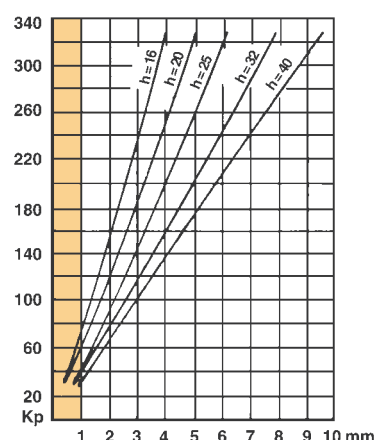

ø 20 - 95 SH
 25% di compres. max

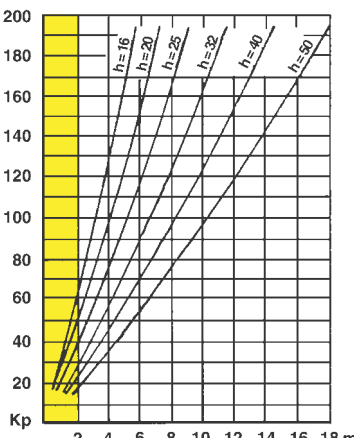

ø 25 - 80 SH
 35% di compres. max

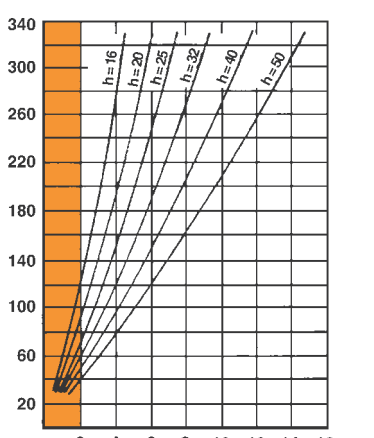

ø 25 - 90 SH
 30% di compres. max

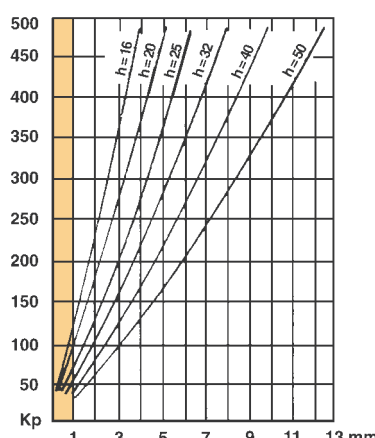

ø 25 - 95 SH
 25% di compres. max

Diagramma di carico Molle Retflex
Load diagram for Retflex Springs
Diagramme de charge pour Ressort Retflex

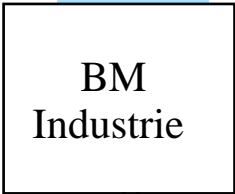

80 Sh
Giallo
Yellow
Jaune
Gelb

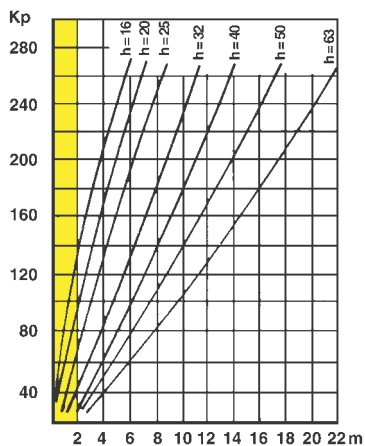

ø 32 - 80 SH
 35% di compres. max

90 Sh
Arancio
Orange
Orange
Orange

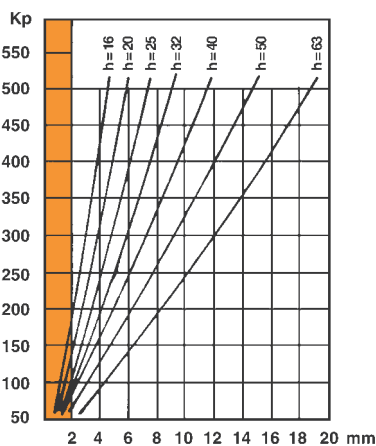

ø 32 - 90 SH
 30% di compres. max

95 Sh
Ocra
Ochre
Ochre
Ocker

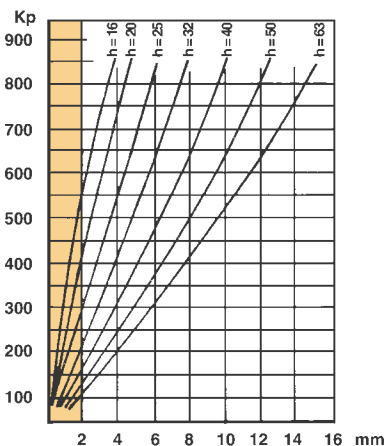

ø 32 - 95 SH
 25% di compres. max

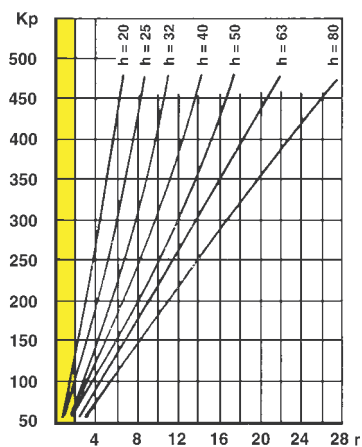

ø 40 - 80 SH
 35% di compres. max

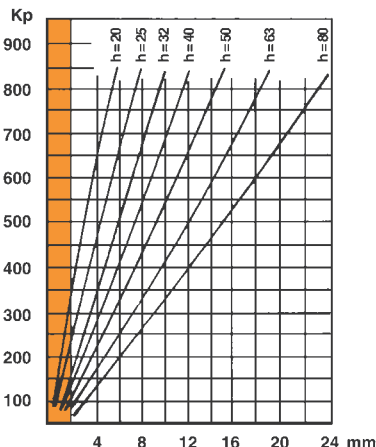

ø 40 - 90 SH
 30% di compres. max

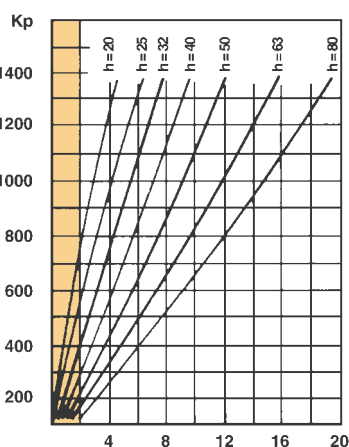

ø 40 - 95 SH
 25% di compres. max

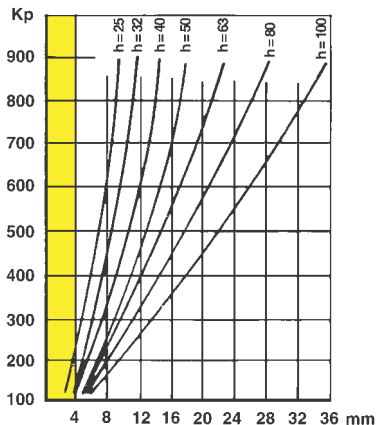

ø 50 - 80 SH
 35% di compres. max

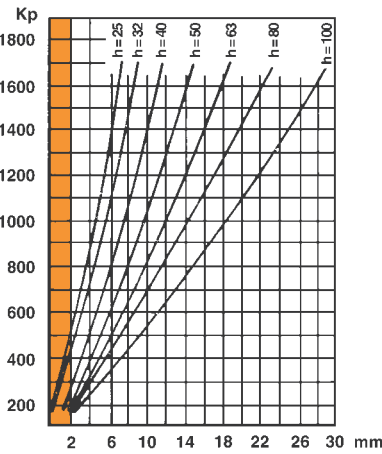

ø 50 - 90 SH
 30% di compres. max

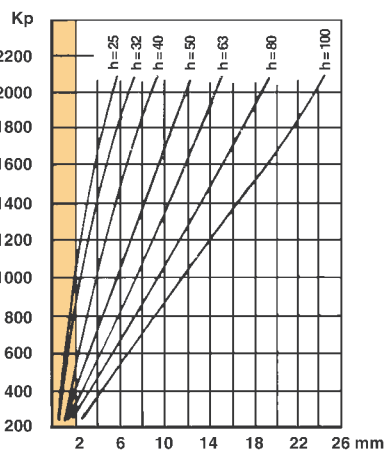

ø 50 - 95 SH
 25% di compres. max

Diagramma di carico Molle Retflex
Load diagram for Retflex Springs
Diagramme de charge pour Ressorts Retflex

BM
Industrie

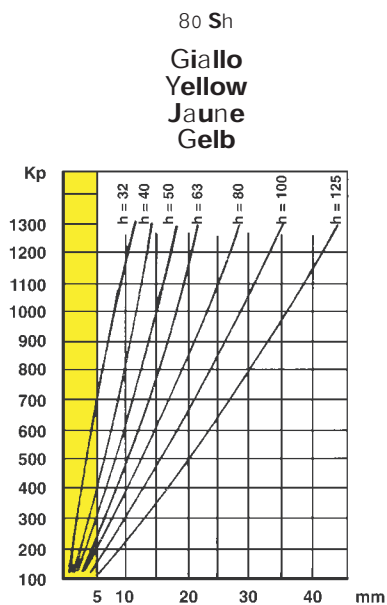

ø 63 - 80 SH
 35% di compres. max

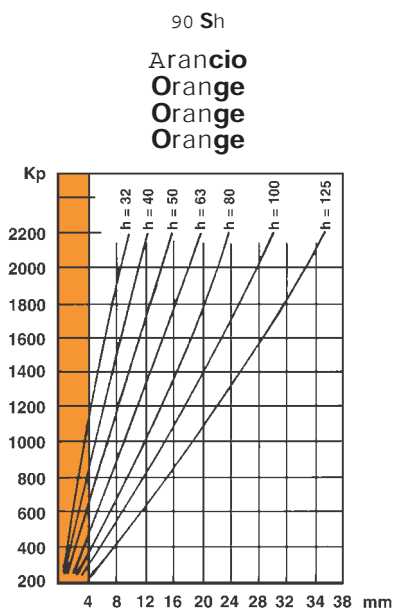

ø 63 - 90 SH
 30% di compres. max

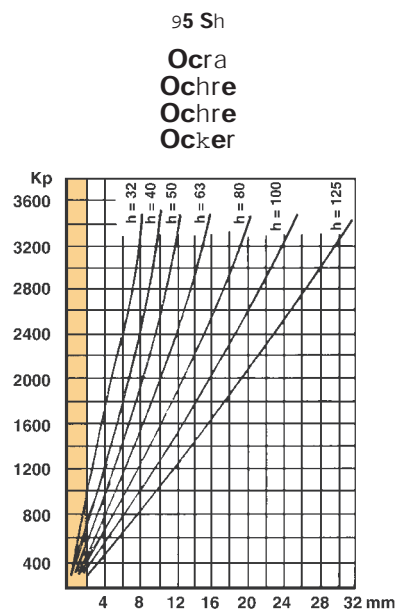

ø 63 - 95 SH
 25% di compres. max

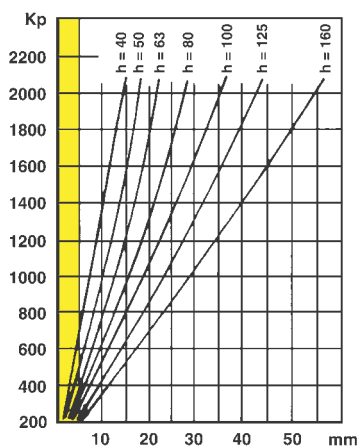

ø 80 - 80 SH
 35% di compres. max

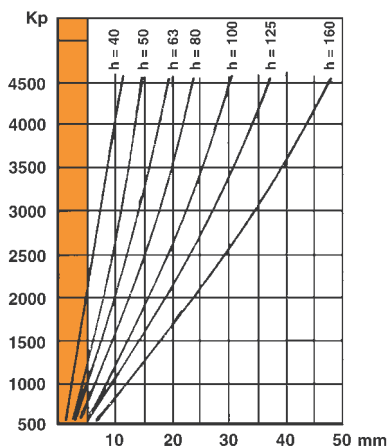

ø 80 - 90 SH
 30% di compres. max

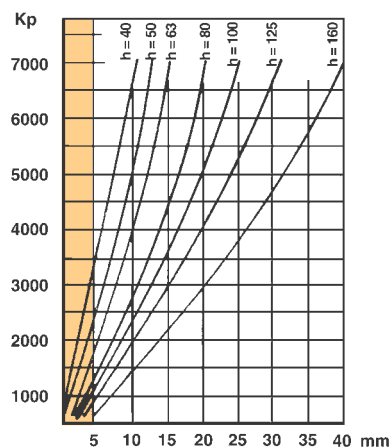

ø 80 - 95 SH
 25% di compres. max

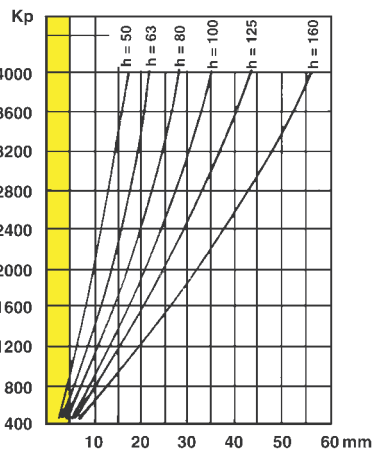

ø 100 - 80 SH
 35% di compres. max

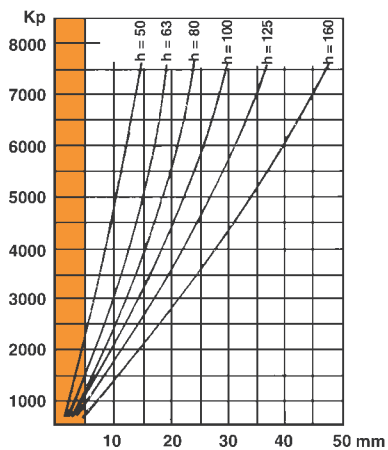

ø 100 - 90 SH
 30% di compres. max

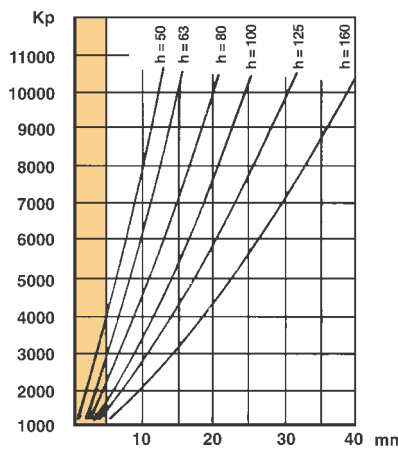

ø 100 - 95 SH
 25% di compres. max

Diagramma di carico Molle Retflex
Load diagram for Retflex Springs
Diagramme de charge pour Ressortes Retflex

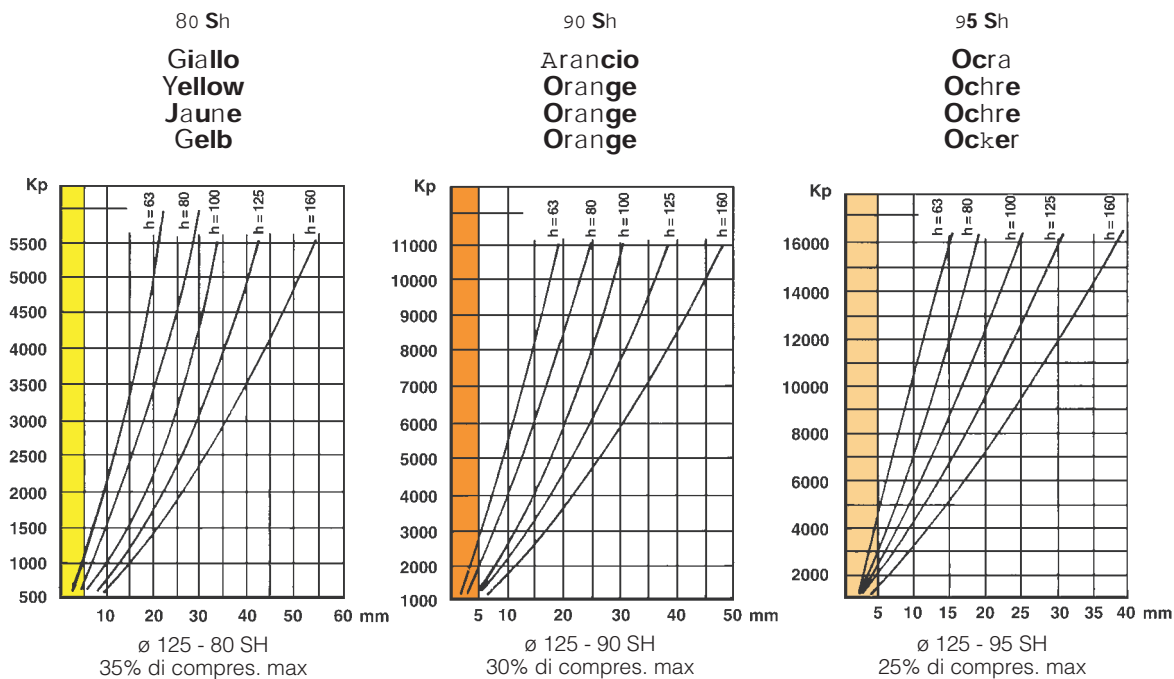

ESEMPIO DI LETTURA DIAGRAMMI

Si vuole sapere quanti Kg. di carico può dare una molla di \varnothing 40H. 80, durezza 90SH. (arancio) per una compressione di 16 mm., pari al 20% dell'altezza.

Nel diagramma relativo riportiamo in ascissa i valori relativi alla compressione espressi in mm., in ordinata quelli relativi al carico KP espressi in Kg.

Dal punto di ascissa pari a 16 mm, saliamo sulla retta delle ordinate fino ad incontrare la curva relativa ad una molla H. 80.

In tale punto la curva assumerà un determinato valore del carico (Kp), in ordinata, di Kg. 525. Vi raccomandiamo di non superare i limiti di compressione del 35% per il giallo 80 Sh. del 30% per il rosso 90 Sh. del 25% il grigio 95 Sh; in questo modo le molle avranno una lunga durata.

Tutte le molle sollecitate dinamicamente si surriscaldano; tale calore è provocato dalla compressione, dalla frequenza dei colpi e dagli attriti sul sistema di guida, tale temperatura non deve mai superare i 70°C.

EXAMPLE TO HELP DIAGRAMS INTERPRETATION

To know the load in kgs of one spring having diam. 40H. 80, hardness 90SH (orange), under a compression of 16 mm, which is equal to 20% of the height.

In the relevant diagram we gave, in vertical, the values covering the compression in mm and in horizontal those covering the KP load in kgs.

From the vertical point, the curve will have a specific load value (Kp), in horizontal, of 525 kgs. We strongly recommend not to exceed the compression limits, namely:

- 35% for 80 Sh., yellow
- 30% for 90 Sh., red
- 25% for 95 Sh., grey

In this way the springs will have a longer life.

All dynamically stressed springs will overheat, the heat being caused by the compression, by the number of strokes and by the friction on the guides.

Please note that this temperature should never exceed 70° C.

**Viti a testa cilindrica
con gambo rettificato esagono incassato**
Shoulder screws
Vises epaulées
Paßschrauben

**BM
Industrie**

ISO 7379 - 12.9

**Acciaio
Steel
Acier
Werkstoff**

per viteria
for bolts and screws
pour visserie
für Schrauben

Resistenza alla rottura per
trazione / Tensile strength:
120 Kg/mm²

Limite di elasticità / Limit of
elasticity:
90/Kg/mm² min.

Allungamento / Stretch:
9% min.

Grado di tolleranza del gambo
rettificato / Tolerance rate of
the ground shaft:
h 8

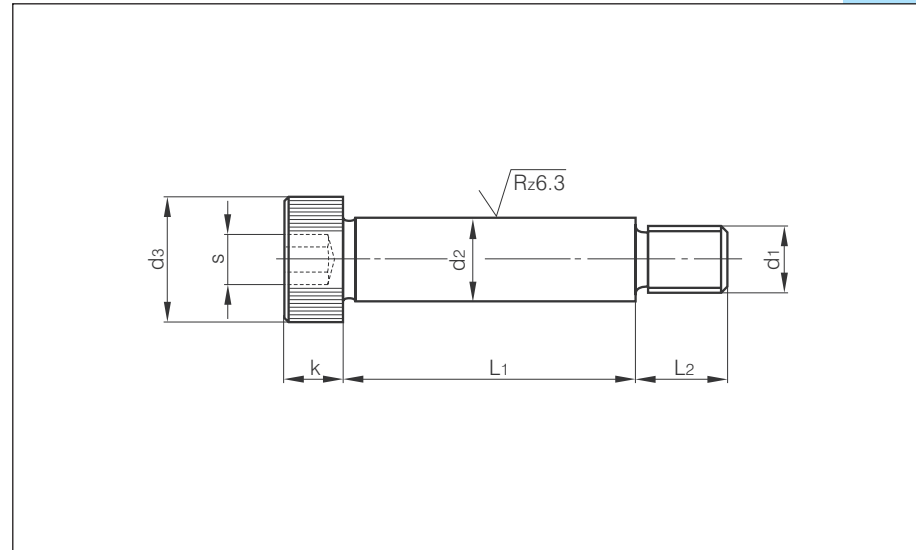

d2h8	5	6	8	10	12	16	20	24
d1	4 x	5 x 0,8	6 x 1	8 x 1,25	10 x 1,5	12 x 1,75	16 x 2	20 x 2,5
d3	8	10	13	16	18	24	30	36
K	4	4,5	5,5	7	9	10	14	16
L2	8	9,5	11	13	16	18	22	27
S = esagono	2,5	3	4	5	6	8	10	12
Kg./m m	0,49	0,68	1,15	3	6	11	28	55
L1	L1							
10								
12								
16								
20								
25								
30								
35								
40								
45								
50								
55								
60								
65								
70								
80								
90								
100								
120								
140								
160								
200								

A richiesta si eseguono
misure fuori catalogo

Non-standard dimensions
can be made on request

Viti a colletto con distanziale rettificato
Shoulder screws with ground spacer
Vises avec entretoise rectifiée
Schrauben mit Distanzrohr geschliffen

Acciaio
Steel
Acier
Werkstoff

per viteria
 for bolts and screws
 pour visserie
 für Schrauben

Rondella / Washer:
 acciaio temprato e brunito,
 resistenza 100 Kg/mm²
 steel heat-treated and burnished,
 strenght 100 Kg/mm²

Distanziale / Spacer Data:
 acciaio temprato e rettificato,
 resistenza 120-140 Kg/mm²
 steel heat-treated and grinded,
 strenght 120-140 Kg/mm²

Tolleranza di rettificazione /
Tolerance of grinding:
 D = h 7

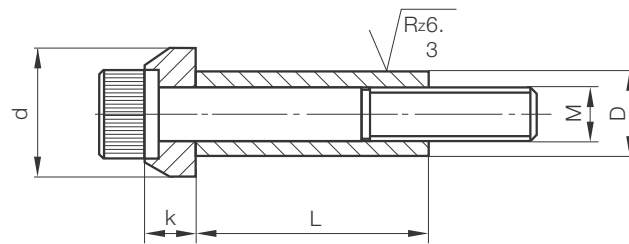

filetto M	6 M A	8 M A	10 M A	12 M A	16 M A
k	6	6,5	7,5	9	11
d	15	19	23	27	34
D	10	12,5	15	17,5	23
L	L = ±0,05 mm				
15					
20					
25					
30					
35					
40					
45					
50					
55					
60					
65					
70					
80					
90					
100					
110					
120					
140					
150					
160					
180					
200					
220					
230					

Pressori con molla
Thrust springs screws
Vises à bille à ressort
Federne Druckstücke

BM
Industrie

Acciaio
Steel
Acier
Werkstoff

Class 5,8

Trattamento superficiale
 Brunito
 Sfera completamente
 temperata lucida
 Acciaio inox, lucido

Surface treatment
 Burnished
 Sphere completely hardened
 and lapped
 Bright stainless steel

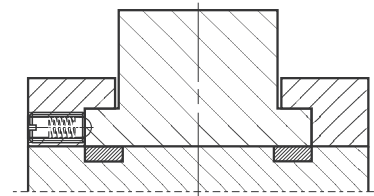
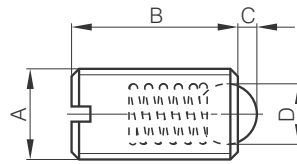

Pressore a molla come riferimento innestabile a spinta

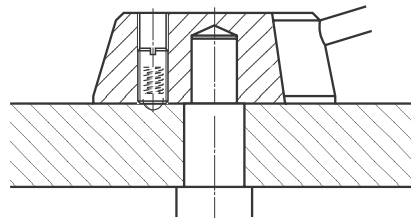

Pressore a molla come riferimento innestabile a mezzo leva

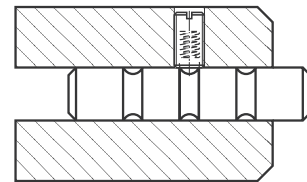

Pressore a molla come posizionamento su albero scanalato

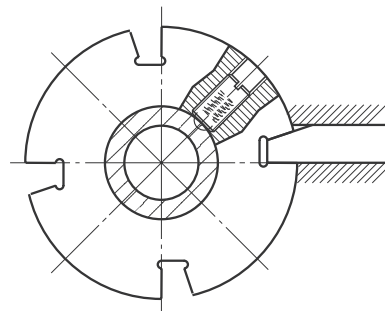

Pressore a molla come arresto supplementare su divisore

A	B	C	D	Forze Forze Iniziale Initial N	Forze Forze Finale Final N
M 4	9	0,8	2,5	6	12
M 5	12	0,9	3	7	13
M 6	14	1,0	3,5	9	15
M 8	16	1,5	5	20	35
M 10	19	2,0	6	25	45
M 12	22	2,5	8	35	60
M 16	24	3,5	10	65	110

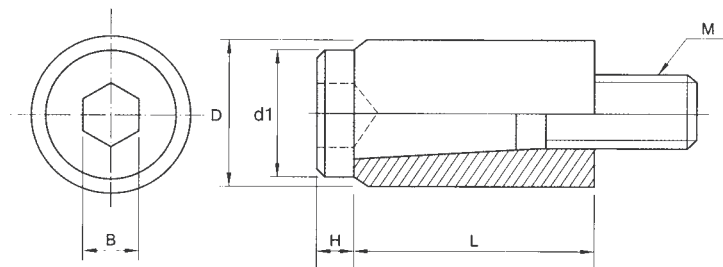

D	D1	M	B	L	H		
10	8,5	5	4	18	3	vite e nylon	
12	11,5	6	5	20	4,5	completo	
13	11,25	6	5	20	4,5	vite e nylon	
16	14	8	6	25	4,5	completo	
20	16	10	8	30	5,5	vite e nylon	

Blocchi portastampo

Die sets

Blocs à Colonnes

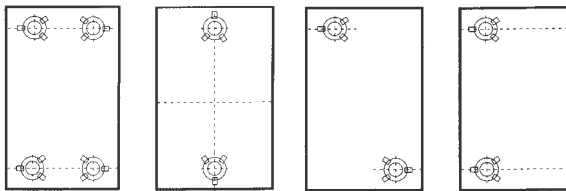

BM
Industrie

La nostra azienda presenta in questo catalogo la produzione di serie relativa a:-

- basi portastampo a 2 o 3 piastre con colonne e bussole del tipo fisso nei montaggi a 4 colonne e 2 colonne nelle 3 diverse conformazioni: arretrate, centrali, diagonali.

Su richiesta siamo in grado di:

- eseguire piastre e basi con dimensioni diverse da quelle di seguito riportate
- eseguire lavorazioni a disegno del cliente
- fornire basi con scorrimenti guida frutto della combinazione, a scelta del cliente, fra i diversi tipi di bussole e colonne illustrati nell'ultima parte di questo catalogo
- fornire piastre spianate e squadrate con esecuzione delle alesature sedi delle colonne e bussole

Tutte le piastre sia singole che costituenti una base montata sono realizzate in UNI C 45, finite di rettifica sui piani e di fresa sui lati.

Le tolleranze di serie sono:

- sulle dimensioni esterne $\pm 1\%$ della misura nominale
- sugli spessori ± 2 mm
- parallelismo dei piani a base montata 0,015 su 100 mm

Le illustrazioni, le dimensioni e i pesi riportati nel presente catalogo sono indicativi.

Our company presents in this catalogue her standard production of:

- Die-sets of 2 or 3 plates with fixed pins and bushings in the 4 guides type and/or in the 2 guides type diagonal, central or rear mounted.

On special request, we are able to:

- manufacture plates and die-sets in special sizes;
- make tooling according to customer's drawing;
- supply die-sets with guide elements chosen by the customer among those showed in the last section of this catalogue;
- Supply plates with ground surfaces, milled sides and bored holes fit to the pins and bushings assembling.

All standard die-sets and plates are made in UNI C 45 steel.

Standard margins are as follow:

- on overall dimensions $\pm 1\%$ of nominal dimensions;
- on thickness ± 2 mm;
- parallelism on mounted die-sets surfaces 0,015 mm/100 mm.

All illustrations, sizes and weights are given for general guidance only.

Dans ce catalogue, notre Société présente l'ensemble de production standard concernant:

- Blocs à colonnes à 2 et 3 plaques avec colonnes et bagues de guidage du type fixe, à 4 colonnes ou à 2 colonnes dans les 3 positionnements suivants: en diagonal, dans l'axe ou à l'arrière.

Selon les besoins du client, nous sommes a même:

- de réaliser des plaques et des blocs de dimensions spéciales;
- d'exécuter des usinages suivant plan client (creusures, embrèvements, dégagements pour bidage etc...)
- de fournir des plaques rectifiées et chanfreinées avec alésage des sièges des colonnes et des bagues.

Toutes les plaques, autant les plaques simples que celles formant bloc, sont réalisées en acier UNI C 45.

Les tolérances de fabrication standards sont les suivantes:

- sur les dimensions hors tout $\pm 1\%$ des dimensions nominales
- sur les épaisseurs ± 2 mm
- parallélisme des plans su blocs montés 0,015 sur 100 mm.

Les illustrations, cotes et poids mentionnés dans le present catalogue sont fournis à titre indicatif.

Portastampi a quattro colonne
Bussole e colonne tipo fisso
Die-sets with 4 pins,
fixed bushings and fixed pins

BM
Industrie

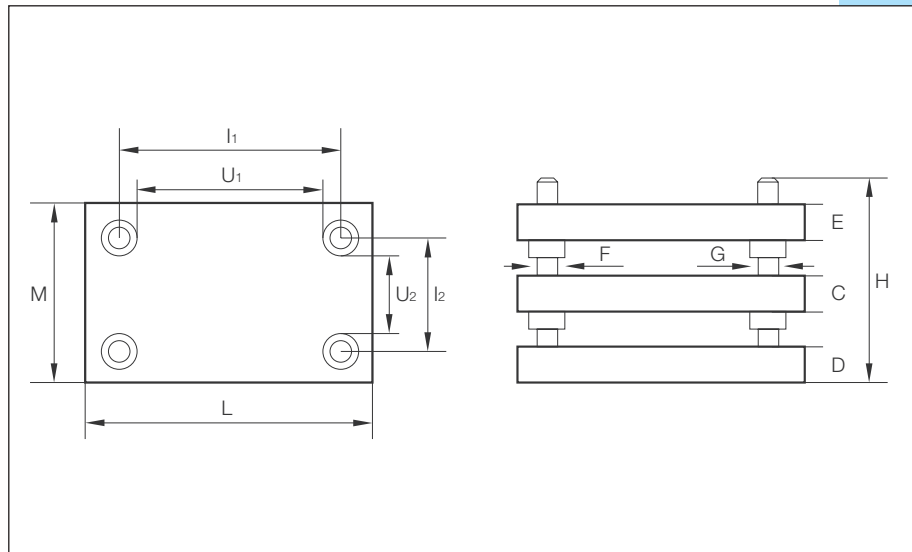

Dimensioni nominali mm / Nominal dimensions mm

Codice	L	M	D	E	C	F-G	H	I ₁	I ₂	U ₁	U ₂	Kg. 2 piastre	Kg. 3 piastre
3001	200	150	28	28	23	18	145	150	100	122	72	14	19
3002			38			18	145	150	100	122	72	17	21
3003		175	28			18	145	150	125	122	97	17	21
3004			38			18	145	150	125	122	97	20	24
3005		200	28			18	145	150	150	122	122	19	23
3006			38			18	145	150	150	122	122	22	28
3007	250	200	33	33	28	25	155	192	142	156	106	28	35
3008			38			25	155	192	142	156	106	30	38
3009		250	33			25	155	192	192	156	156	35	47
3010			38			25	155	192	192	156	156	38	49
3011	300	200	38	38	23	25	170	242	142	206	106	38	48
3012			48			25	170	242	142	206	106	43	52
3013		250	38		28	30	185	230	180	185	135	48	62
3014			48			30	185	230	180	185	135	54	68
3015		300	38		30	185	230	230	185	185	58	75	
3016			48		30	185	230	230	185	185	65	82	
3017	350	200	38	38	23	25	185	292	142	256	106	45	55
3018			48			25	185	292	142	256	106	50	61
3019		250	38		28	30	185	280	180	235	135	56	72
3020			48			30	185	280	180	235	135	63	79
3021	300	38	33	30	185	280	230	235	185	67	91		
3022		48		30	185	280	230	235	185	76	99		
3023	350	38	33	30	185	280	280	235	235	78	106		
3024		48		30	185	280	280	235	235	88	116		
3025	400	200	38	38	28	25	185	342	142	306	106	51	66
3026			48			25	185	342	142	306	106	58	73
3027		250	38		30	185	330	180	285	135	64	83	
3028			48		30	185	330	180	285	135	72	91	

Portastampi a quattro colonne
Bussole e colonne tipo fisso
Die-sets with 4 pins,
fixed bushings and fixed pins

BM
Industrie

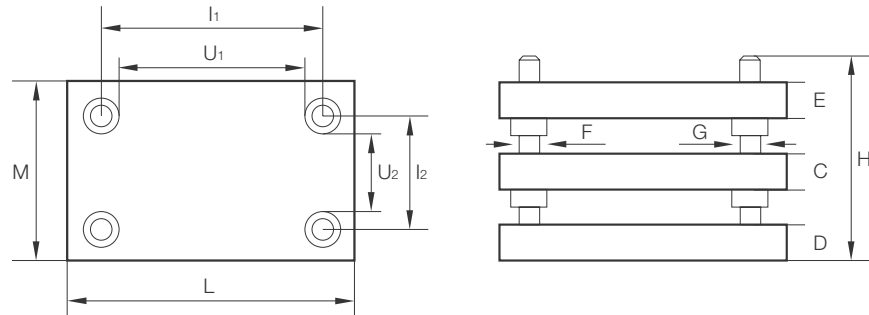

Dimensioni nominali mm / Nominal dimensions mm

Codice	L	M	D	E	C	F-G	H	I ₁	I ₂	U ₁	U ₂	Kg. 2 piastre	Kg. 3 piastre				
3029	400	300	48	48	33	40	200	315	215	260	160	96	124				
3030			58			40	200	315	215	260	160	106	133				
3031		350	48			40	200	315	265	260	210	112	144				
3032			58			40	200	315	265	260	210	123	156				
3033		400	48			40	200	315	315	260	260	128	165				
3034			58			40	200	315	315	260	260	141	178				
3035	450	250	48			48	33	40	200	365	165	310	110	90	116		
3036			58					40	200	365	165	310	110	99	125		
3037		300	48					40	200	365	215	310	160	108	139		
3038			58					40	200	365	215	310	160	119	150		
3039		350	48					40	200	365	265	310	210	126	162		
3040			58					40	200	365	265	310	210	139	175		
3041		450	48					40	200	365	365	310	310	162	208		
3042			58					40	200	365	365	310	310	178	225		
3043	500	300	48					48	33	40	200	415	215	360	160	120	155
3044			58							40	200	415	215	360	160	132	167
3045		400	48							40	200	415	315	360	260	160	214
3046			58							40	200	415	315	360	260	176	230
3047		500	48	40	200					415	415	360	360	200	268		
3048			58	40	200					415	415	360	360	220	288		
3049	600	300	48	48	38					40	200	515	215	460	160	144	193
3050			58							40	200	515	215	460	160	158	207
3051		350	48							40	200	515	265	460	210	168	225
3052			58							40	200	515	265	460	210	185	242
3053		400	48			40	200			515	315	460	260	192	257		
3054			58			40	200			515	315	460	260	211	276		
3055		500	48			50	200			500	400	430	330	240	322		
3056			58			50	200			500	400	430	330	264	346		
3057		600	48			50	200			500	500	430	430	288	386		
3058			58			50	200			500	500	430	430	317	415		

Portastampi a quattro colonne
Bussole e colonne tipo fisso
Die-sets with 4 pins,
fixed bushings and fixed pins

BM
Industrie

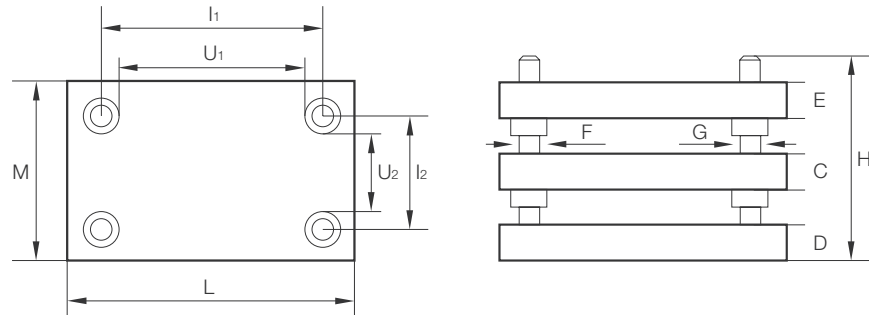

Dimensioni nominali mm / Nominal dimensions mm

Codice	L	M	D	E	C	F-G	H	I ₁	I ₂	U ₁	U ₂	Kg. 2 piastre	Kg. 3 piastre
3059	700	300	48	48	38	40	200	615	215	560	160	168	225
3060			48			40	200	615	215	560	160	185	242
3061		400	58	58		50	200	600	300	530	230	246	322
3062				58		50	200	600	300	530	230	269	345
3063		500	58	48		50	200	600	400	530	330	308	403
3064				58		50	200	600	400	530	330	336	431
3065		600	58	48		50	200	600	500	530	430	370	484
3066				58		50	200	600	500	530	430	403	517
3067		700	58	48		50	200	600	600	530	530	431	565
3068				58		50	200	600	600	530	530	470	604
3069	800	300	48	48	43	40	200	715	215	660	160	192	257
3070			48			40	200	715	215	660	160	211	277
3071		400	58	58		50	200	700	300	630	230	282	368
3072				58		50	200	700	300	630	230	307	394
3073		500	58	48		50	200	700	400	630	330	352	461
3074				58		50	200	700	400	630	330	384	493
3075		600	58	48		50	200	700	500	630	430	422	553
3076				58		50	200	700	500	630	430	461	591
3077		700	58	48		50	200	700	600	630	530	493	667
3078				58		50	200	700	600	630	530	538	712
3079	1000	300	58	48	43	50	200	900	200	830	130	264	358
3080				58		50	200	900	200	830	130	288	382
3081		400	58	48		50	200	900	300	830	230	352	477
3082				58		50	200	900	300	830	230	384	509
3083		500	58	48		50	200	900	400	830	330	440	596
3084				58		50	200	900	400	830	330	480	636
3085		600	58	48		50	200	900	500	830	430	528	715
3086				58		50	200	900	500	830	430	576	730
3087		800	58	48		50	200	900	700	830	630	704	954
3088				58		50	200	900	700	830	630	768	1018

Portastampi a due colonne centrali
Bussole e colonne tipo fisso
Die-sets with 2 pins central,
fixed bushings and fixed pins

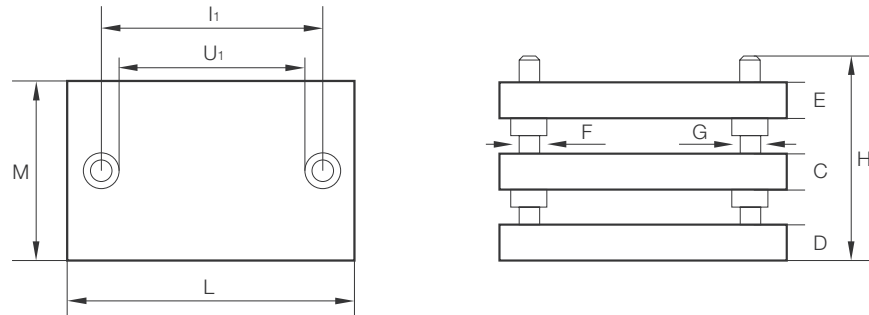

Dimensioni nominali mm / Nominal dimensions mm

Code	L	M	D	E	C	F-G	H	I ₁	U ₁	U ₂	Kg. 2 plate	Kg. 3 plate		
4001	125	125	23	23	18	17/18	125	75	47	125	6	10		
4002			33			17/18	125	75	47	125	8	12		
4003	140	80	23			17/18	125	90	62	80	4	5		
4004			28			17/18	125	90	62	80	5	6		
4005	150	125	23		23	17/18	125	100	72	125	8	12		
4006			28		17/18	125	100	72	125	9	14			
4007		150	28		18	24/25	125	92	56	150	11	17		
4008			38		23	24/25	125	92	56	150	13	19		
4009	175	175	28	28	23	24/25	125	117	81	175	15	23		
4010			38			24/25	125	117	81	175	17	26		
4011	170	100	28		18	18	17/18	125	120	92	100	8	10	
4012			33				17/18	125	120	92	100	9	11	
4013	200	120	28			23	23	17/18	145	150	122	120	12	14
4014			33					17/18	145	150	122	120	13	15
4015		150	28		24/25	145		142	106	150	14	19		
4016			38		24/25	145		142	106	150	17	21		
4017		175	28		24/25	145		142	106	175	17	23		
4018			38		24/25	145		142	106	175	20	25		
4019	200	200	28	23	23	24/25	155	142	106	200	19	25		
4020			38			24/25	155	142	106	200	22	28		
4021	250	150	33			33	28	24/25	155	192	156	150	21	27
4022			38					24/25	155	192	156	150	23	30
4023		200	33					24/25	155	192	156	200	28	38
4024			38					24/25	155	192	156	200	30	40
4025	250	250	33	28	28	30/31	170	180	135	250	35	50		
4026			38			30/31	170	180	135	250	38	52		

Portastampi a due colonne centrali
Bussole e colonne tipo fisso
Die-sets with 2 pins central,
fixed bushings and fixed pins

BM
Industrie

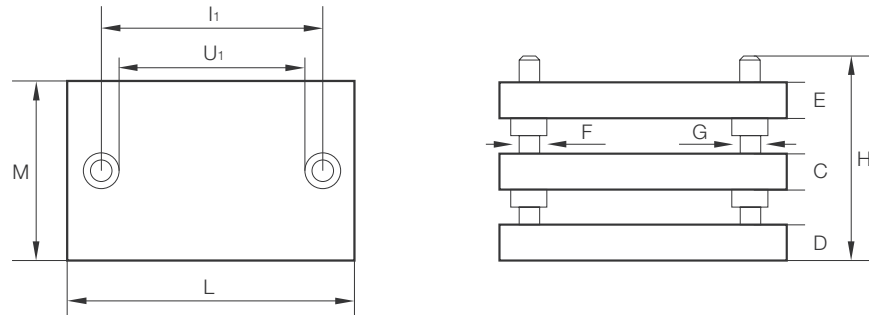

Dimensioni nominali mm / Nominal dimensions mm

Code	L	M	D	E	C	F-G	H	I ₁	U ₁	U ₂	Kg. 2 plates	Kg. 3 plates	
4027	300	150	33	33	23	24/25	170	242	206	150	25	34	
4028			38			24/25	170	242	206	150	27	36	
4029		200	38	38		28	24/25	170	242	206	200	38	47
4030			48				24/25	170	242	206	200	43	52
4031		250	38		28	30/31	170	230	185	250	48	66	
4032			48				30/31	170	230	185	250	54	72
4033		300	38			30/31	170	230	185	300	58	79	
4034			48								30/31	170	230
4035	350	200	38		23	24/25	185	292	256	200	45	59	
4036			48				24/25	185	292	256	200	50	64
4037		250	38	28		30/31	185	280	235	250	56	77	
4038			48				30/31	185	280	235	250	63	84
4039		300	38	33	30/31	200	280	235	300	67	96		
4040			48			30/31	200	280	235	300	76	105	
4041		350	38		40/41	200	280	235	350	78	113		
4042			48							40/41	200	280	235
4043	400	200	38	28	24/25	185	342	306	200	51	70		
4044			48			24/25	185	342	306	200	58	77	
4045		250	38		33	30/31	200	330	285	250	64	92	
4046			48				30/31	200	330	285	250	72	100
4047		300	48	40/41		200	315	260	300	96	129		
4048			58							40/41	200	315	260
4049		350	48	48	40/41	200	315	260	350	112	151		
4050			58			40/41	200	315	260	350	123	163	
4051	400	48	40/41		200	315	260	400	128	173			
4052		58							40/41	200	315	260	400

Portastampi a due colonne centrali
Bussole e colonne tipo fisso
Die-sets with 2 pins central,
fixed bushings and fixed pins

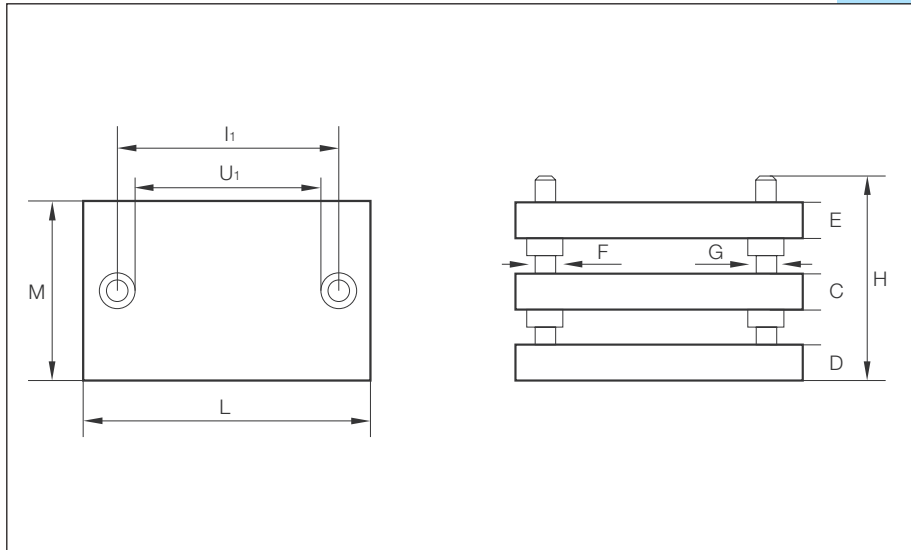
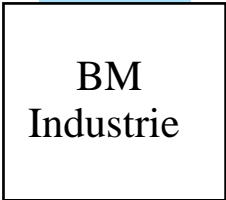

Dimensioni nominali mm / Nominal dimensions mm

Code	L	M	D	E	C	F-G	H	I1	U1	U2	Kg. 2 plates	Kg. 3 plates	
4053	450	250	48	48	33	30/31	200	380	335	250	90	116	
4054			58			30/31	200	380	335	250	99	125	
4055		350	48			40/41	200	365	310	350	126	163	
4056			58			40/41	200	365	310	350	139	175	
4057		450	48			40/41	200	365	310	450	162	209	
4058			58			40/41	200	365	310	450	178	226	
4059		500	300			48	40/41	200	415	360	300	120	155
4060						58	40/41	200	415	360	300	132	167
4061	400		48	40/41	200	415	360	400	160	215			
4062			58	40/41	200	415	360	400	176	230			
4063	500		48	50/51	200	400	330	500	200	268			
4064			58	50/51	200	400	330	500	220	288			
4065	600		300	48	48	38	50/51	200	500	430	300	144	193
4066				58			50/51	200	500	430	300	158	207
4067		350	48	50/51			200	500	430	350	168	225	
4068			58	50/51			200	500	430	350	185	242	
4069		400	48	50/51			200	500	430	400	192	257	
4070			58	50/51			200	500	430	400	211	276	
4071		500	48	50/51			200	500	430	500	240	322	
4072			58	50/51			200	500	430	500	264	346	
4073	600	48	50/51	200	500	430	600	288	386				
4074		58	50/51	200	500	430	600	317	415				
4075	700	300	48	58	38	50/51	200	600	530	300	168	225	
4076			58			50/51	200	600	530	300	185	242	
4077		400	48			50/51	200	600	530	400	246	323	
4078			58			50/51	200	600	530	400	269	345	

Portastampi a due colonne centrali
Bussole e colonne tipo fisso
Die-sets with 2 pins central,
fixed bushings and fixed pins

BM
Industrie

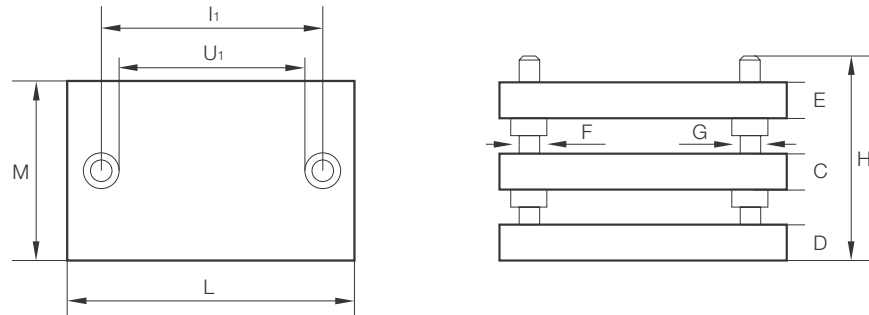

Dimensioni nominali mm / Nominal dimensions mm

Code	L	M	D	E	C	F-G	H	I1	U1	U2	Kg. 2 plates	Kg. 3 plates	
4079	700	500	58	48	38	50/51	200	600	530	500	308	403	
4080				58		50/51	200	600	530	500	336	431	
4081		600		48		50/51	200	600	530	600	370	484	
4082				58		50/51	200	600	530	600	403	517	
4083		700		700		48	50/51	200	600	530	700	431	565
4084						58	50/51	200	600	530	700	470	604
4085	800	300	58	48	38	50/51	200	700	630	300	211	277	
4086				58		50/51	200	700	630	300	230	296	
4087		400		48		50/51	200	700	630	400	282	369	
4088				58		50/51	200	700	630	400	307	395	
4089		500		500		48	50/51	200	700	630	500	352	461
4090						58	50/51	200	700	630	500	384	493
4091	1000	600	58	48	38	50/51	200	700	630	600	422	553	
4092				58		50/51	200	700	630	600	461	591	
4093		700		700		48	50/51	200	700	630	700	493	645
4094						58	50/51	200	700	630	700	538	690
4095		300		300		48	50/51	200	900	830	300	264	346
4096						58	50/51	200	900	830	300	288	370
4097	400	400	48	50/51	200	900	830	400	352	461			
4098			58	50/51	200	900	830	400	384	493			
4099	500	500	48	50/51	200	900	830	500	440	576			
4100			58	50/51	200	900	830	500	480	616			
4101	600	600	48	50/51	200	900	830	600	528	691			
4102			58	50/51	200	900	830	600	576	740			
4103	800	800	48	50/51	200	900	830	800	704	922			
4104			58	50/51	200	900	830	800	768	986			

Portastampi a due colonne diagonali
Bussole e colonne tipo fisso
Die-sets with 2 pins diagonal,
fixed bushings and fixed pins

BM Industrie

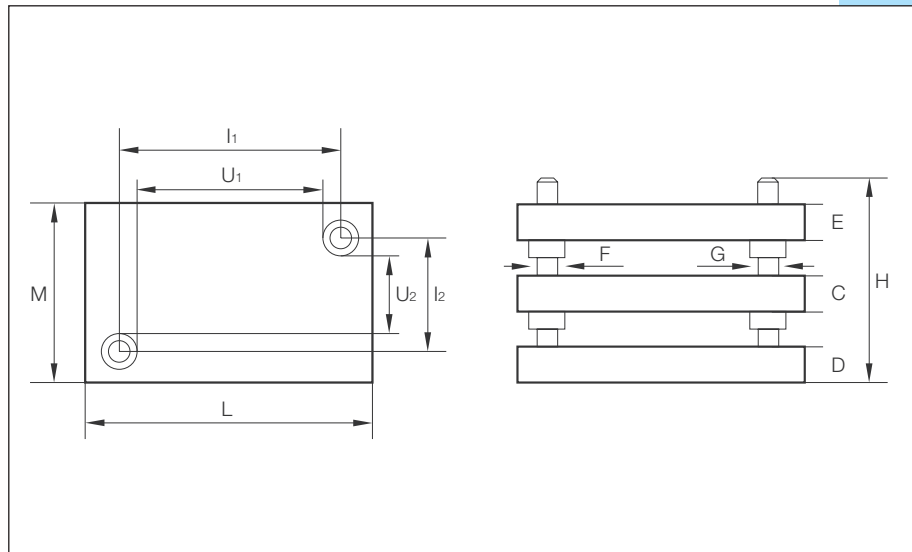

Dimensioni nominali mm / Nominal dimensions mm

Codice	L	M	D	E	C	F-G	H	I ₁	I ₂	U ₁	U ₂	Kg. 2 piastre	Kg. 3 piastre	
5001	125	125	23	23	18	17/18	125	75	75	47	47	6	10	
5002			33			17/18	125	75	75	47	47	8	12	
5003	140	80	23			17/18	125	90	30	62	2	4	5	
5004			28			17/18	125	90	30	62	2	5	6	
5005	150	125	23		23	17/18	125	100	75	72	47	8	12	
5006			28		17/18	125	100	75	72	47	9	14		
5007		150	28		18	24/25	125	92	92	56	56	11	17	
5008			38		23	24/25	125	92	92	56	56	13	19	
5009	175	175	28		23	18	24/25	125	117	117	81	81	15	23
5010			38				24/25	125	117	117	81	81	17	26
5011	170	100	28	28	18	17/18	125	120	50	92	22	8	10	
5012			33			17/18	125	120	50	92	22	9	11	
5013	200	120	28			17/18	145	150	70	122	42	12	14	
5014			33			17/18	145	150	70	122	42	13	15	
5015		150	28		24/25	145	142	92	106	56	14	19		
5016			38		24/25	145	142	92	106	56	17	21		
5017	175	28	24/25		145	142	117	106	81	17	23			
5018		38	24/25		145	142	117	106	81	20	25			
5019	200	28	24/25		155	142	142	106	106	19	25			
5020		38	24/25		155	142	142	106	106	22	28			
2021	250	150	33	33	23	24/25	155	192	92	156	56	21	27	
5022			38			24/25	155	192	92	156	56	23	30	
5023		200	33			24/25	155	192	142	156	106	28	38	
5024			38			24/25	155	192	142	156	106	30	40	
5025		250	33			28	30/31	170	180	180	135	135	35	50
5026			38			28	30/31	170	180	180	135	135	38	52

Portastampi a due colonne diagonali
Bussole e colonne tipo fisso
Die-sets with 2 pins diagonal,
fixed bushings and fixed pins

BM
Industrie

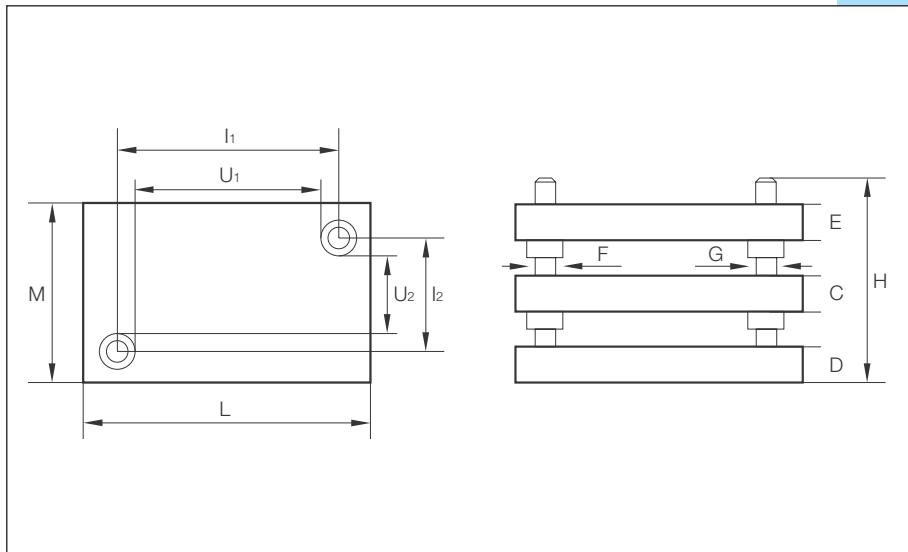

Dimensioni nominali mm / Nominal dimensions mm

Codice	L	M	D	E	C	F-G	H	I ₁	I ₂	U ₁	U ₂	Kg. 2 piastre	Kg. 3 piastre	
5027	300	150	33	33	23	24/25	170	242	92	206	56	25	34	
5028			38			24/25	170	242	92	206	56	27	36	
5029		200	38			24/25	170	242	142	206	106	38	47	
5030			48			24/25	170	242	142	206	106	43	52	
5031		250	38		38	28	30/31	170	230	180	185	135	48	66
5032			48				30/31	170	230	180	185	135	54	72
5033			38				30/31	170	230	230	185	185	58	79
5034			48				30/31	170	230	230	185	185	65	86
5035	350	200	38	38	23	24/25	185	292	142	256	106	45	59	
5036			48			24/25	185	292	142	256	106	50	64	
5037		250	38		28	30/31	185	280	180	235	135	56	77	
5038			48			30/31	185	280	180	235	135	63	84	
5039		300	38		33	33	30/31	200	280	230	235	185	67	96
5040			48				30/31	200	280	230	235	185	76	105
5041			38				40/41	200	280	280	235	235	78	113
5042			48				40/41	200	280	280	235	235	88	122
5043	400	200	38	48	28	24/25	185	342	142	306	106	51	70	
5044			48			24/25	185	342	142	306	106	58	77	
5045		250	38		33	33	30/31	200	330	180	285	135	64	92
5046			48				30/31	200	330	180	285	135	72	100
5047		300	38		33	33	40/41	200	315	215	260	160	96	129
5048			58				40/41	200	315	215	260	160	106	140
5049		350	48		33	33	40/41	200	315	265	260	210	112	151
5050			58				40/41	200	315	265	260	210	123	163
5051	400	48	33	33	40/41	200	315	315	260	260	128	173		
5052		58			40/41	200	315	315	260	260	141	186		

Portastampi a due colonne diagonali
Bussole e colonne tipo fisso
Die-sets with 2 pins diagonal,
fixed bushings and fixed pins

BM
Industrie

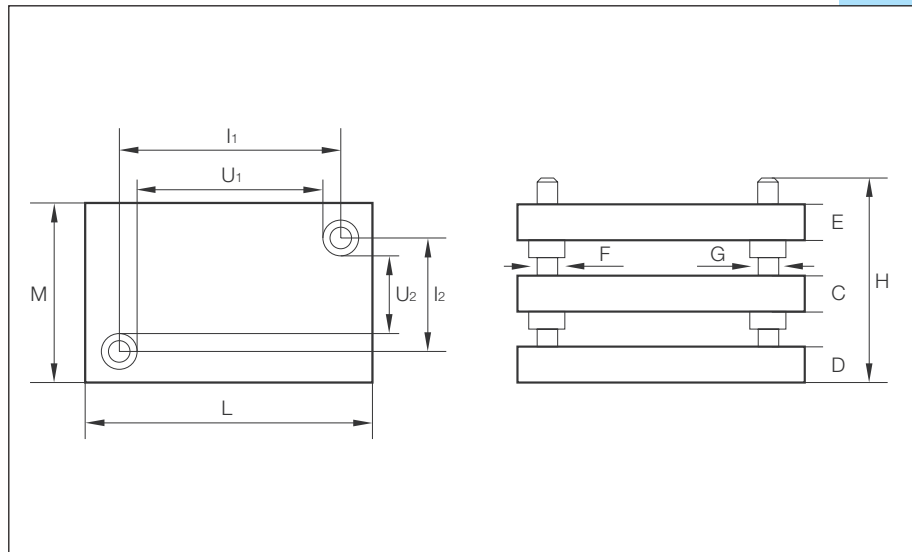

Dimensioni nominali mm / Nominal dimensions mm

Codice	L	M	D	E	C	F-G	H	I1	I2	U1	U2	Kg. 2 piastre	Kg. 3 piastre			
5053	450	250	48	33	33	30/31	200	380	180	335	135	90	116			
5054			58			30/31	200	380	180	335	135	99	125			
5055		350	48			40/41	200	365	265	310	210	126	163			
5056			58			40/41	200	365	265	310	210	139	175			
5057		450	48			40/41	200	365	365	310	310	162	209			
5058			58			40/41	200	365	365	310	310	178	226			
5059		500	300			48	40/41	200	415	215	360	160	120	155		
5060						58	40/41	200	415	215	360	160	132	167		
5061			400			48	40/41	200	415	315	360	260	160	215		
5062						58	40/41	200	415	315	360	260	176	230		
5063			500			48	50/51	200	400	400	330	330	200	268		
5064						58	50/51	200	400	400	330	330	220	288		
5065			600			300	48	48	50/51	200	500	200	430	130	144	193
5066							58	50/51	200	500	200	430	130	158	207	
5067	350			48	50/51	200	500	250	430	180	168	225				
5068				58	50/51	200	500	250	430	180	185	242				
5069	400	48		38	50/51	200	500	300	430	230	192	257				
5070		58		50/51	200	500	300	430	230	211	276					
5071	700	500	48	38	50/51	200	500	400	430	330	240	322				
5072			58	50/51	200	500	400	430	330	264	346					
5073		600	48	50/51	200	500	500	430	430	288	386					
5074			58	50/51	200	500	500	430	430	317	415					
5075		400	300	48	50/51	200	600	200	530	130	168	225				
5076				58	50/51	200	600	200	530	130	185	242				
5077	400		48	50/51	200	600	300	530	230	246	323					
5078			58	50/51	200	600	300	530	230	269	345					

Portastampi a due colonne diagonali
Bussole e colonne tipo fisso
Die-sets with 2 pins diagonal,
fixed bushings and fixed pins

BM Industrie

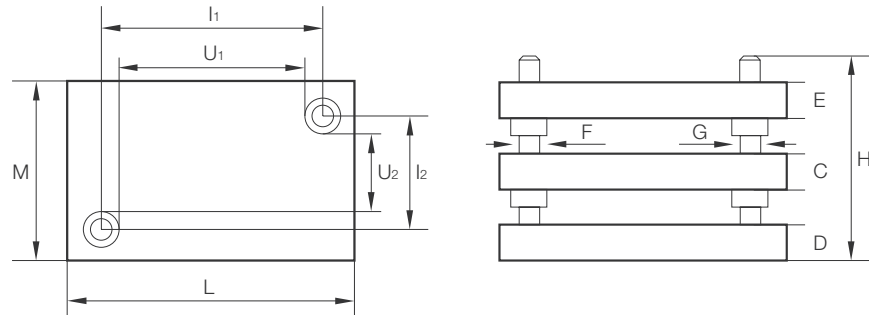

Dimensioni nominali mm / Nominal dimensions mm

Codice	L	M	D	E	C	F-G	H	I ₁	I ₂	U ₁	U ₂	Kg. 2 piastre	Kg. 3 piastre
5079	700	500	58	48	38	50/51	200	600	400	530	330	308	403
5080				58		50/51	200	600	400	530	330	336	431
5081		600		48		50/51	200	600	500	530	430	370	484
5082				58		50/51	200	600	500	530	430	403	517
5083		700		48		50/51	200	600	600	530	530	431	565
5084				58		50/51	200	600	600	530	530	470	604
5085	800	300		48		50/51	200	700	200	630	130	211	277
5086				58		50/51	200	700	200	630	130	230	296
5087		400		48		50/51	200	700	300	630	230	282	369
5088				58		50/51	200	700	300	630	230	307	395
5089		500		48		50/51	200	700	400	630	330	352	461
5090				58		50/51	200	700	400	630	330	384	493
5091	1000	600	48	50/51	200	700	500	630	430	422	553		
5092			58	50/51	200	700	500	630	430	461	591		
5093		700	48	50/51	200	700	600	630	530	493	645		
5094			58	50/51	200	700	600	630	530	538	690		
5095		300	48	50/51	200	900	200	830	130	264	346		
5096			58	50/51	200	900	200	830	130	288	370		
5097	400	48	50/51	200	900	300	830	230	352	461			
5098		58	50/51	200	900	300	830	230	384	493			
5099	500	48	50/51	200	900	400	830	330	440	576			
5100		58	50/51	200	900	400	830	330	480	616			
5101	600	48	50/51	200	900	500	830	430	528	691			
5102		58	50/51	200	900	500	830	430	576	740			
5103	800	48	50/51	200	900	700	830	630	704	922			
5104		58	50/51	200	900	700	830	630	768	986			

Portastampi a due colonne posteriori
Bussole e colonne tipo fisso
Die-sets with 2 pins rear,
fixed bushings and fixed pins

BM
Industrie

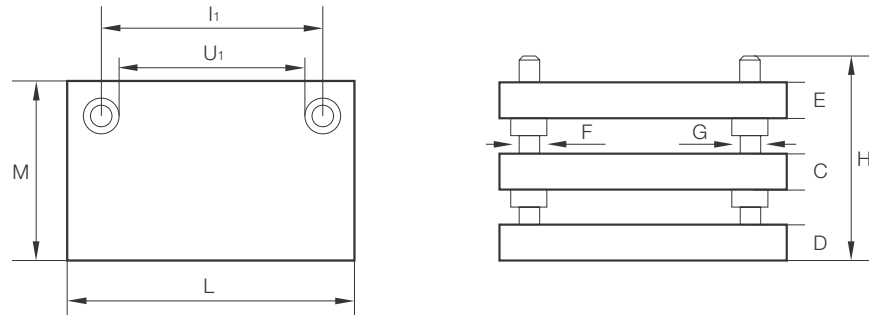

Dimensioni nominali mm / Nominal dimensions mm

Code	L	M	D	E	C	F-G	H	I ₁	U ₁	U ₂	Kg. 2 plates	Kg. 3 plates					
6001	125	125	23	23	18	17/18	125	75	47	86	6	10					
6002			33			17/18	125	75	47	86	8	12					
6003	140	80	23			23	18	17/18	125	90	62	41	4	5			
6004			28					17/18	125	90	62	41	5	6			
6005	150	125	23		28	23	17/18	125	100	72	86	8	12				
6006			28				17/18	125	100	72	86	9	14				
6007		150	28			18	23	24/25	125	92	56	103	11	17			
6008			38					24/25	125	92	56	103	13	19			
6009	175	175	28			28	23	24/25	125	117	81	128	15	23			
6010			38					24/25	125	117	81	128	17	26			
6011	170	100	28	18			23	17/18	125	120	92	61	8	10			
6012			33					17/18	125	120	92	61	9	11			
6013	200	120	28		23			18	17/18	145	150	122	81	12	14		
6014			33						17/18	145	150	122	81	13	15		
6015		150	28						23	18	24/25	145	142	106	103	14	19
6016			38								24/25	145	142	106	103	17	21
6017	175	28	23	18			24/25	145		142	106	128	17	23			
6018		38					24/25	145		142	106	128	20	25			
6019	200	28		28		23	18	24/25		155	142	106	153	19	25		
6020		38						24/25		155	142	106	153	22	28		
6021	250	150	33			33	23	18	24/25	155	192	156	103	21	27		
6022			38						24/25	155	192	156	103	23	30		
6023		200	33		23			18	24/25	155	192	156	153	28	38		
6024			38						24/25	155	192	156	153	30	40		
6025		250	33	28				18	30/31	170	180	135	192	35	50		
6026			38						30/31	170	180	135	192	38	52		

Portastampi a due colonne posteriori
Bussole e colonne tipo fisso
Die-sets with 2 pins rear,
fixed bushings and fixed pins

BM
Industrie

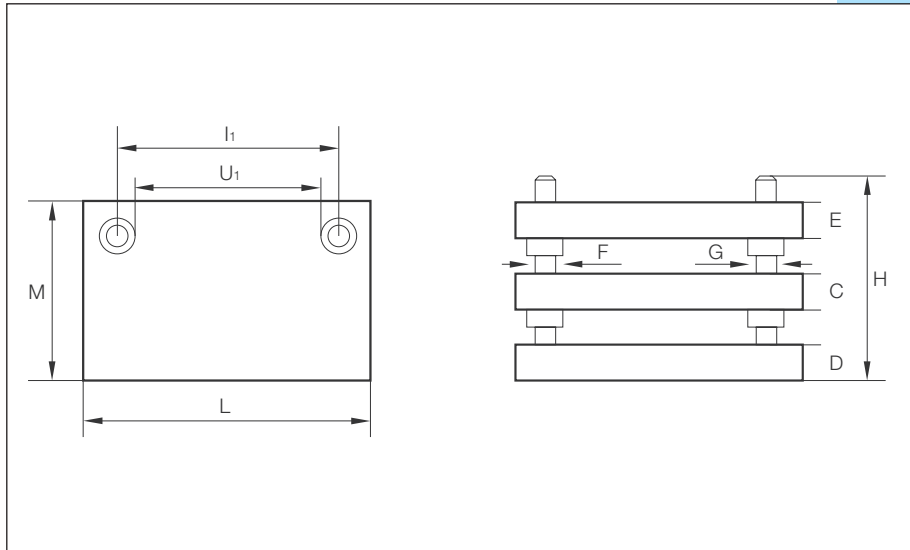

Dimensioni nominali mm / Nominal dimensions mm														
Code	L	M	D	E	C	F-G	H	I ₁	U ₁	U ₂	Kg. 2 plates	Kg. 3 plates		
6027	300	150	33	33	23	24/25	170	242	206	103	25	34		
6028			38			24/25	170	242	206	103	27	36		
6029		200	38			24/25	170	242	206	153	38	47		
6030			48			24/25	170	242	206	153	43	52		
6031		250	38		48	28	30/31	170	230	185	192	48	66	
6032							30/31	170	230	185	192	54	72	
6033			300				38	30/31	170	230	185	242	58	79
6034							48	30/31	170	230	185	242	65	86
6035	350	200	38	38	23	24/25	185	292	256	153	45	59		
6036			48			24/25	185	292	256	153	50	64		
6037		250	38		28	30/31	185	280	235	192	56	77		
6038			48			30/31	185	280	235	192	63	84		
6039		300	38		33	33	30/31	200	280	235	242	67	96	
6040			48				30/31	200	280	235	242	76	105	
6041			350				38	40/41	200	280	235	280	78	113
6042							48	40/41	200	280	235	280	88	122
6043	400	200	38	48	28	24/25	185	342	306	153	51	70		
6044			48			24/25	185	342	306	153	58	77		
6045		250	38		33	33	30/31	200	330	285	192	64	92	
6046			48				30/31	200	330	285	192	72	100	
6047		300	48				40/41	200	315	260	230	96	129	
6048			58				40/41	200	315	260	230	106	140	
6049		350	48		48	33	40/41	200	315	260	280	112	151	
6050			58				40/41	200	315	260	280	123	163	
6051	400	48	48	33	40/41	200	315	260	330	128	173			
6052		58			40/41	200	315	260	330	141	186			

Portastampi a due colonne posteriori
Bussole e colonne tipo fisso
Die-sets with 2 pins rear,
fixed bushings and fixed pins

BM
Industrie

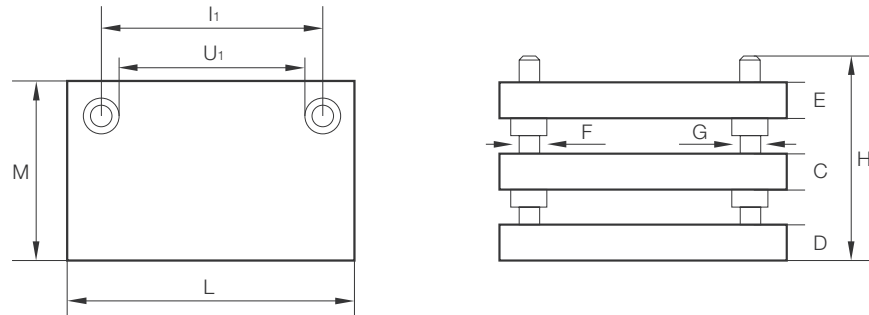

Dimensioni nominali mm / Nominal dimensions mm

Code	L	M	D	E	C	F-G	H	I ₁	U ₁	U ₂	Kg. 2 plate	Kg. 3 plate			
6053	300	250	48	48	33	30/31	200	380	335	192	90	116			
6054			58			30/31	200	380	335	192	99	125			
6055		350	48			40/41	200	365	310	280	126	163			
6056			58			40/41	200	365	310	280	139	175			
6057		450	48			40/41	200	365	310	380	162	209			
6058			58			40/41	200	365	310	380	178	226			
6059		500	300			48	48	38	40/41	200	415	360	230	120	155
6060						58			40/41	200	415	360	230	132	167
6061			400			48			40/41	200	415	360	330	160	215
6062						58			40/41	200	415	360	330	176	230
6063	500		48	50/51	200	400			330	415	200	268			
6064			58	50/51	200	400			330	415	220	288			
6065	600		300	48	48	38			50/51	200	500	430	215	144	193
6066				58					50/51	200	500	430	215	158	207
6067			350	48					50/51	200	500	430	265	168	225
6068				58					50/51	200	500	430	265	185	242
6069		400	48	50/51			200	500	430	315	192	257			
6070			58	50/51			200	500	430	315	211	276			
6071		500	48	50/51			200	500	430	415	240	322			
6072			58	50/51			200	500	430	415	264	346			
6073		600	48	50/51			200	500	430	515	288	386			
6074			58	50/51			200	500	430	515	317	415			
6075	700	300	48	58	38	50/51	200	600	530	215	168	225			
6076			58			50/51	200	600	530	215	185	242			
6077		400	48			50/51	200	600	530	315	246	323			
6078			58			50/51	200	600	530	315	269	345			

Portastampi a due colonne posteriori
Bussole e colonne tipo fisso
Die-sets with 2 pins rear,
fixed bushings and fixed pins

BM
Industrie

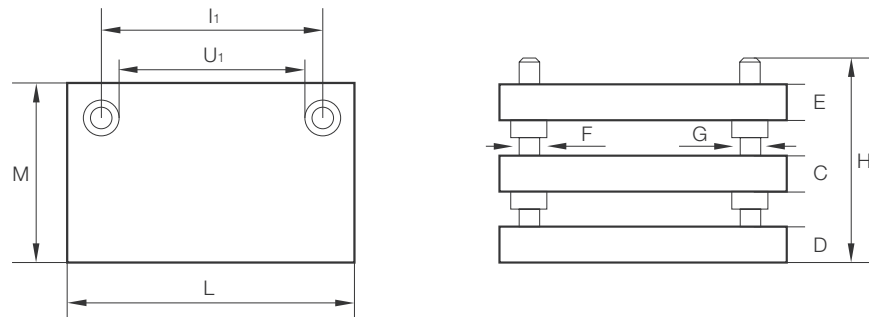

Dimensioni nominali mm / Nominal dimensions mm

Code	L	M	D	E	C	F-G	H	I ₁	U ₁	U ₂	Kg. 2 plates	Kg. 3 plates			
6079	700	500	58	48	38	50/51	200	600	530	415	308	403			
6080				58		50/51	200	600	530	415	336	431			
6081		600		48		50/51	200	600	530	515	370	484			
6082				58		50/51	200	600	530	515	403	517			
6083		700		700		48	50/51	200	600	530	615	431	565		
6084						58	50/51	200	600	530	615	470	604		
6085	800	300		48		58	38	50/51	200	700	630	215	211	277	
6086				58				50/51	200	700	630	215	230	296	
6087		400		48				50/51	200	700	630	315	282	369	
6088				58				50/51	200	700	630	315	307	395	
6089		500		500				48	50/51	200	700	630	415	352	461
6090								58	50/51	200	700	630	415	384	493
6091	1000	600	48	58	38			50/51	200	700	630	515	422	553	
6092			58					50/51	200	700	630	515	461	591	
6093		700	700					48	50/51	200	700	630	615	493	645
6094								58	50/51	200	700	630	615	538	690
6095		300	300					48	50/51	200	900	830	215	264	346
6096								58	50/51	200	900	830	215	288	370
6097	400	400	48			50/51	200	900	830	315	352	461			
6098			58			50/51	200	900	830	315	384	493			
6099	500	500	48			50/51	200	900	830	415	440	576			
6100			58			50/51	200	900	830	415	480	616			
6101	600	600	48			50/51	200	900	830	515	528	691			
6102			58			50/51	200	900	830	515	576	740			
6103	800	800	48	50/51	200	900	830	715	704	922					
6104			58	50/51	200	900	830	715	768	986					

Estrattori con testa svasata
Conical head ejectors
Éjecteurs à tête conique
Auswerferstifte

DIN I530
Forma D

Acciaio
Steel
Acier
Werkstoff

Ws

Durezza
Hardness
Dureté
Härte

Gam bo: 60/62 HRC
 Testa: 45 ± 5 HRC

Shaft: 60/62 HRC
 Head: 45 ± 5 HRC

Cop: 60/62 HRC
 Tête: 45 ± 5 HRC

Schaft: 60/62 HRC
 Kopf: 45 ± 5 HRC

Esecuzione
Finish
Exécution
Ausführung

Temprati - Rettificati

Hardened - Ground

Trepés - Rectifiés

Gehärtet - Geschliffen

Testa riscalcata a caldo

The head is hot forged

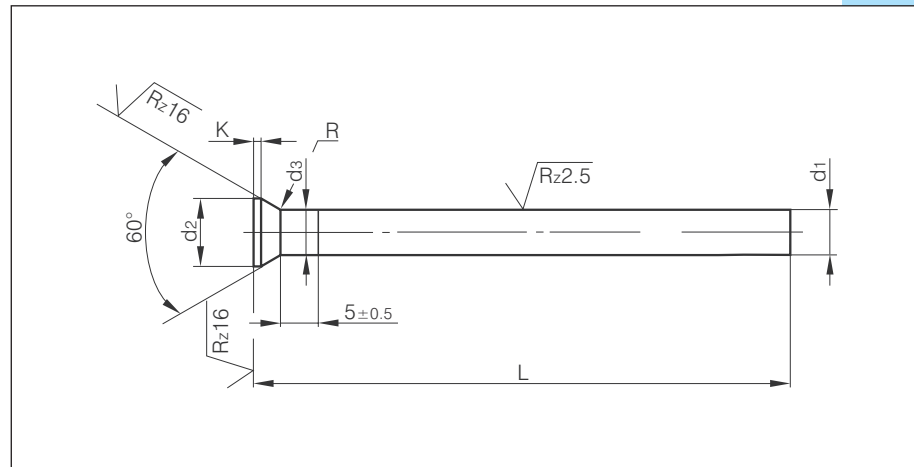

d1 g6	d2 -0,2	K 0/+0,2	R 0/+0,2	d3	L 0/+2						
					125	160	200	250	315		
0,5	0,9	0,2	0,3	d1 +0,02							
0,6	1,1	0,2									
0,7	1,3	0,2									
0,8	1,4	0,4									
0,9	1,6	0,4									
1,0-1,1	1,8	0,5		0,5	d1 +0,03						
1,2-1,3	2,0	0,5									
1,4-1,5	2,2	0,5									
1,6-1,7	2,5	0,5									
1,8-1,9	2,8	0,5									
2,0	3,0	0,5									
2,1-2,2	3,2	0,5									
2,3-2,5	3,5	0,5									
2,6-2,9	4,0	0,5									
3,0-3,4	4,5	0,5	0,8			d1 +0,04					
3,5-3,9	5,0	0,5									
4,0-4,4	5,5	0,5									
4,5-4,9	6,0	0,5									
5,0-5,4	6,5	0,5									
5,5-5,9	7,0	0,5									
6,0-6,4	8,0	0,5									
6,5-7,4	9,0	1,0									
7,5-8,4	10,0	1,0									
8,5-9,4	11,0	1,0									
9,5-10,4	12,0	1,0									
10,5-11,4	13,0	1,0									
11,5-12,4	14,0	1,0									
12,5-13,4	15,0	1,0									
13,5-14,4	16,0	1,0									
14,5-15,0	17,0	1,5									
15,1-16,0	18,0	1,5									
16,1-17,0	19,0	1,5									
17,1-18,0	20,0	1,5									
18,1-19,0	21,0	1,5									
19,1-20,0	22,0	1,5									
20,1-22,0	24,0	1,5									

Espulsori con testa cilindrica temprati
Hardened ejector pins cyl. head
Éjecteurs tête cylindrique trempés
Auswerferstifte zyl. Kopf gehärtet

BM
Industrie

Tipo Fiat

Acciaio
Steel
Acier
Werkstoff

WS

Durezza
Hardness
Dureté
Härte

Gamma: 60/62 HRC
 Testa: 45 ± 5 HRC

Shaft: 60/62 HRC
 Head: 45 ± 5 HRC

Copp: 60/62 HRC
 Tête: 45 ± 5 HRC

Schaft: 60/62 HRC
 Kopf: 45 ± 5 HRC

Esecuzione
Finish
Exécution
Ausführung

Temprati - Rettificati

Hardened - Ground

Trempés - Rectifiés

Gehärtet - Geschliffen

Testa riscalcata a caldo

The head is hot forged

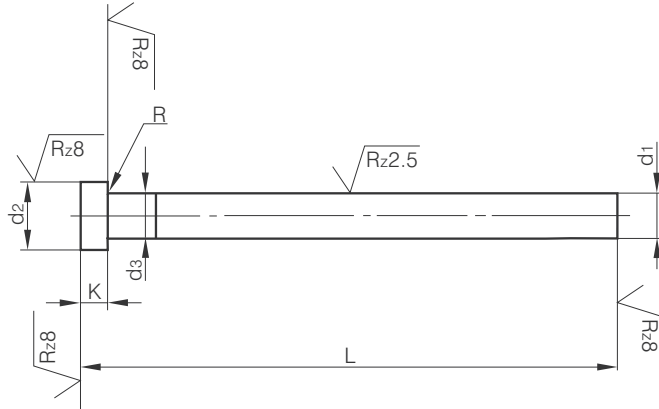

d1 g6	d2 -0,2	K -0,05	R +0,2 0	d3	L / 0 +2						
					100	125	160	200	250	315	400
2	4	2	0,2	d1 +0,03							
2,2											
2,5	5	3	0,3								
3	6										
3,5	7										
4	8	4									
5	10	5	0,5								
6	12										
7											
8	14	6,5	0,5								
10	17										
12	20	7	0,8	d1							
14	22			+0,04							
16	24										
18	26										
20	28		1,0	d1 +0,07							

Espulsori con testa cilindrica nitrurati neri
Nitrided ejector pins form A black
Ejecteur nitrurés forme A noire
Auswerferstifte mit zyl. Kopf nitriert Form A Schwarz

BM
Industrie

DIN ISO 6751 A

Acciaio
Steel
Acier
Werkstoff

DIN 1.2344

Durezza
Hardness
Durété
Härte

Gamma: 65 + 2 HRC
 Testa: 45 ± 5 HRC

Shaft: 65 + 2 HRC
 Head: 45 ± 5 HRC

Corp: 65 + 2 HRC
 Tête: 45 ± 5 HRC

Shaft: 65 + 2 HRC
 Kopf: 45 ± 5 HRC

Esecuzione
Finish
Exécution
Ausführung

Nitrurati - Rettificati

Nitrided - Ground

Nitrurés - Rectifiés

Nitriert - Geschliffen

Testa riscalcata a caldo

The head is hot forged

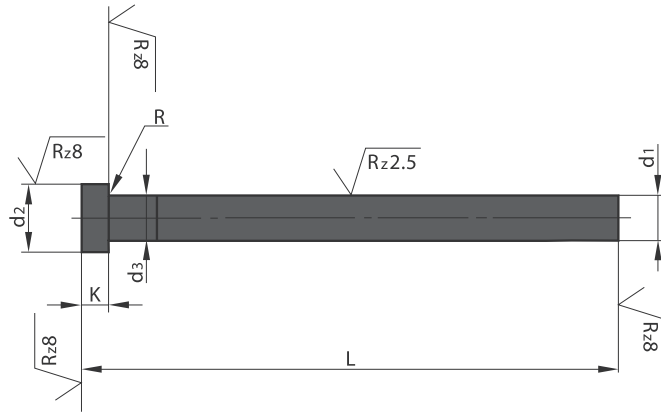

d1 g6	d2 -0,2	K -0,05	R	d3	L / 0 +2																																					
					100	125	160	200	250	315	400	500	630	800	1000																											
1,0	2,5	1,2	0,2	d1+ 0,03																																						
1,1																																										
1,2																																										
1,3	3	1,5			0,3	d1+ 0,03																																				
1,4																																										
1,5																																										
1,6																																										
1,7																																										
1,8																																										
1,9	4	2	0,5				d1+ 0,03																																			
2,0																																										
2,2																																										
2,5				5				3	0,8	d1+ 0,04																																
2,7																																										
3,0																																										
3,2																																										
3,5	7	5			1,0	d1+ 0,07																																				
3,7																																										
4,0																																										
4,2				8				7			1,0	d1+ 0,1																														
4,5																																										
4,7																																										
5,0	10	10	1,0				d1+ 0,1																																			
5,2																																										
5,5																																										
6,0				12				10	1,0	d1+ 0,1																																
6,2																																										
6,5																																										
7,0	14	10			1,0	d1+ 0,1																																				
8,0																																										
8,2																																										
8,5				16				10			1,0	d1+ 0,1																														
9,0																																										
10,0																																										
10,2	18	10	1,0				d1+ 0,1																																			
10,5																																										
11,0																																										
12,0				22				10	1,0	d1+ 0,1																																
12,2																																										
12,5																																										
14,0	24	10			1,0	d1+ 0,1																																				
16,0																																										
18,0																																										
20,0				26				10			1,0	d1+ 0,1																														
25,0																																										
32,0																																										

Espulsori con testa cilindrica nitrurati
Nitrided ejector pins form A
Ejecteur nitrurés forme A
Auswerferstifte mit zyl. Kopf nitriert Form A

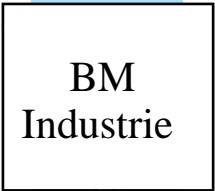

Tipo Fiat

Acciaio
Steel
Acier
Werkstoff

DIN 1.2344

Durezza
Hardness
Durété
Härte

Gamma: 65 + 2 HRC
 Testa: 45 ± 5 HRC

Shaft: 65 + 2 HRC
 Head: 45 ± 5 HRC

Corp: 65 + 2 HRC
 Tête: 45 ± 5 HRC

Shaft: 65 + 2 HRC
 Kopf: 45 ± 5 HRC

Esecuzione
Finish
Exécution
Ausführung

- Nitrurati - Rettificati
- Nitrided - Ground
- Nitrurés - Rectifiés
- Nitriert - Geschliffen

- Testa riscaldata a caldo
- The head is hot forged

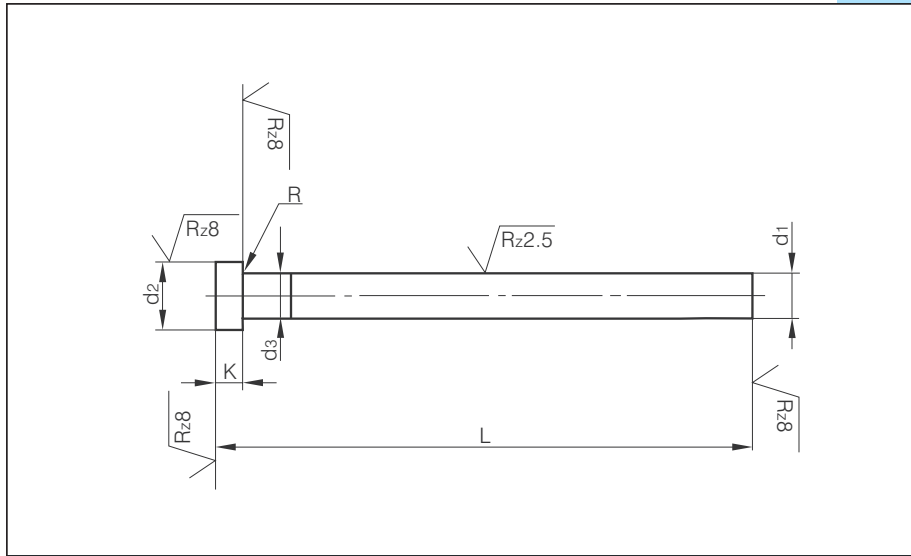

d1 g6	d2 -0,2	K -0,05	R	d3	L / 0 +2												
					100	125	160	200	250	315	400	500	630	800	1000		
2	4	2	0,2	d1 +0,03													
2,2																	
2,5	5	3	0,3														
3																	
3,2	6	4	0,3														
3,5																	
4	8	5	0,5														
5																	
6	12	6,5	0,5														
6,5																	
7	14	7	0,8														
8																	
10	17	7	0,8														
12																	
14	24	7	0,8														
16																	
18	26	7	0,8														
20																	
20	28	1,0	1,0	+0,07													

A richiesta nitrurati nei

Espulsori non nitrurati lavorabili
Core pins
Éjecteurs Broche
Kernstifte Unnitriert

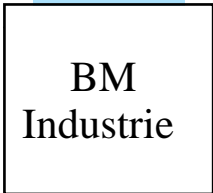

DIN ISO 6751 A

Acciaio
Steel
Acier
Werkstoff

DIN 1.2344

Durezza
Hardness
Durété
Härte

Gam bo: 38 / 45 HRC
 Testa: 45 ± 5 HRC

Shaft: 38 / 45 HRC
 Head: 45 ± 5 HRC

Coip: 38 / 45 HRC
 Tête: 45 ± 5 HRC

Schaft: 38 / 45 HRC
 Kopf: 45 ± 5 HRC

Esecuzione
Finish
Exécution
Ausführung

Rettificati

Ground

Rectifiés

Geschliffen

Testa riscaldata a caldo

The head is hot forged

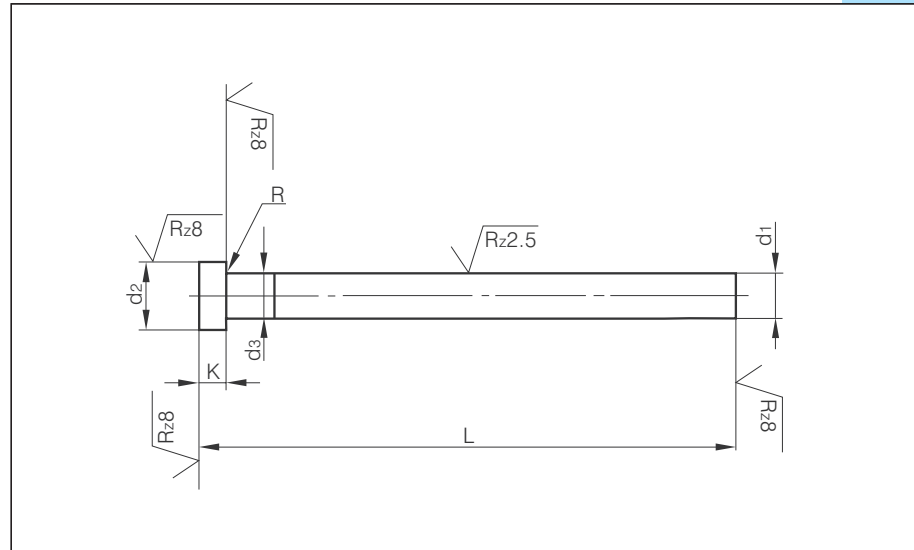

d1 g6	d2 -0,2	K -0,05	R	d3	L / 0 +2												
					100	125	160	200	250	315	400	500	630				
1,5	3	1,5	0,2	d1 +0,03													
2,0	4	2															
2,2																	
2,5			5														
3,0	6	3	0,3														
3,2																	
3,5					7												
3,7	8	5	0,5		d1 +0,04												
4,0																	
4,2																	
4,5	10	7	0,8														
5,0																	
5,2/5,5																	
6,0	12	22															
6,2/6,5/7																	
8,0																	
8,2/8,5/9	14	18															
10,0																	
10,2/10,5																	
11,0	16	22															
12,0																	
12,2																	
12,5	18	22															
14,0																	
16,0																	

Espulsori con testa cilindrica temprati forma C
Hardened ejector pins form C
Éjecteurs trempés form C
Auswerferstifte mit zyl. Kopf gehärtet Form C

BM
Industrie

DIN ISO 8694 CH

Acciaio
Steel
Acier
Werkstoff

WS

Durezza
Hardness
Durété
Härte

Gam bo: 60/62 HRC
 Testa: 45 ± 5 HRC

Shaft: 60/62 HRC
 Head: 45 ± 5 HRC

Corp: 60/62 HRC
 Tête: 45 ± 5 HRC

Schaft: 60/62 HRC
 Kopf: 45 ± 5 HRC

Esecuzione
Finish
Exécution
Ausführung

Temprati - Rettificati

Hardened - Ground

Trempés - Rectifiés

Gehärtet - Geschliffen

Testa ricalcata a caldo

The head is hot forged

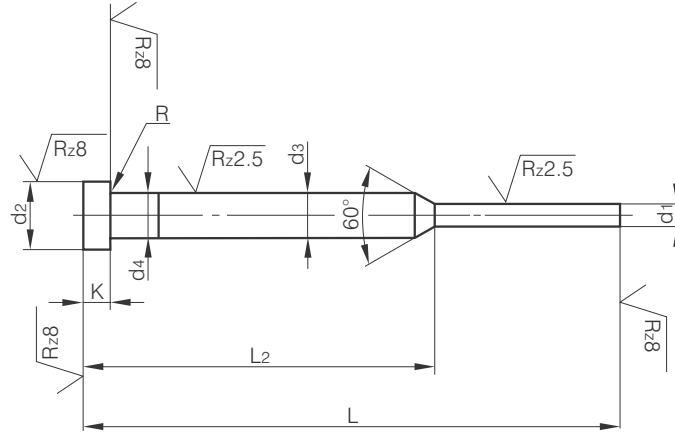

d1 g6	d2 0 -0,2	d3 g6	d4	k 0 -0,05	R +0,2 0	L +2 0			
						100	125	160	200
						L ₂ -1 -2			
						50	50	75	75
da 0,8 a 1,4	4	2		2	0,2				
da 1,5 a 2,4	6	3	d1 + 0,03	3	0,3				
da 2,5 a 2,9	6	3		3	0,3				

Altre misure a richiesta
 Other dimensions on request
 Autres dimensions sur
 demande
 Sonderabmessung auf Anfrage

Nitratati a richiesta
 Nitrided on request
 Niturées sur demande
 Nitiert auf Anfrage

Espulsori con testa cilindrica nitrurati forma C
Nitrided ejector pins form C
Éjecteurs nitrurés form C
Auswerferstifte mit zyl. Kopf nitriert Form C



DIN ISO 8694 C

Acciaio
Steel
Acier
Werkstoff

1.2343

Durezza
Hardness
Durété
Härte

Gamma: 60/62 HRC
 Testa: 45 ± 5 HRC

Shaft: 60/62 HRC
 Head: 45 ± 5 HRC

Copp: 60/62 HRC
 Tête: 45 ± 5 HRC

Schaft: 60/62 HRC
 Kopf: 45 ± 5 HRC

Esecuzione
Finish
Exécution
Ausführung

- Nitrurati - Rettificati
- Nitrided - Ground
- Nitrurés - Rectifiés
- Nitriert - Geschliffen
- Testa ricalcata a caldo
- The head is hot forged

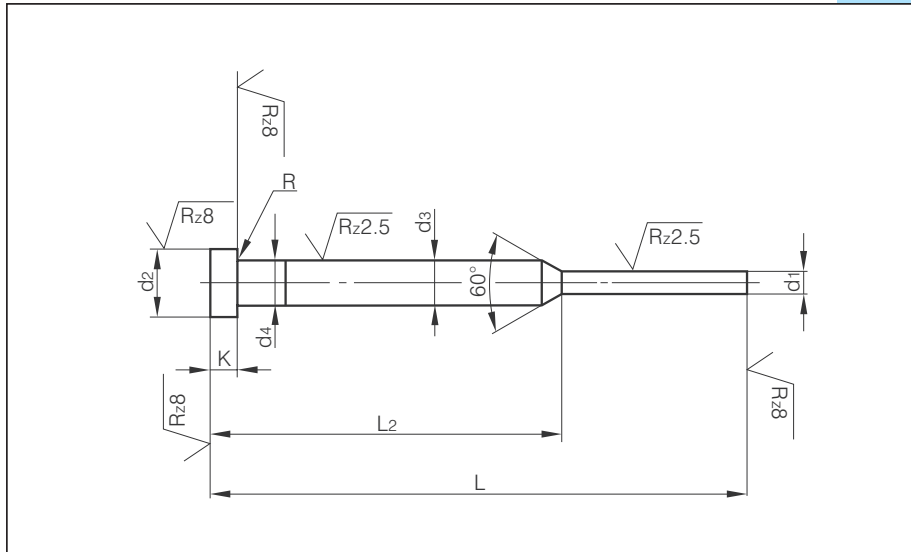

d1 g6	d2 0 -0,2	d3 g6	d4	k 0 -0,05	R +0,2 0	L +2 0			
						100	125	160	200
						L ₂ -1 -2			
						50	50	75	75
da 0,8 a 1,4	4	2	d1 + 0,03	2	0,2				
da 1,5 a 2,4	6	3		3	0,3				
da 2,5 a 2,9	6	3		3	0,3				

Altre misure a richiesta
 Other dimensions on request
 Autres dimensions sur demande
 Sonderabmessung auf Anfrage

Nitrurati a richiesta
 Nitrided on request
 Nitrurés sur demande
 Nitriert auf Anfrage

Espulsori con testa cilindrica nitrurati neri forma C
Black nitrided ejector pins form C
Éjecteurs nitrurés noirs form C
Auswerferstifte mit zyl. Kopf nitriert schwarz Form C

BM
Industrie

DIN ISO 8694 C

Acciaio
Steel
Acier
Werkstoff

1.2343

Durezza
Hardness
Dureté
Härte

Gamma: 60/62 HRC
 Testa: 45 ± 5 HRC

Shaft: 60/62 HRC
 Head: 45 ± 5 HRC

Copp: 60/62 HRC
 Tête: 45 ± 5 HRC

Schaft: 60/62 HRC
 Kopf: 45 ± 5 HRC

Esecuzione
Finish
Exécution
Ausführung

Temprati - Nitruati

Hardened - Nitrided

Trempés - Nitrurés

Gehärtet - Nitriert

Testa riscaldata a caldo

The head is hot forged

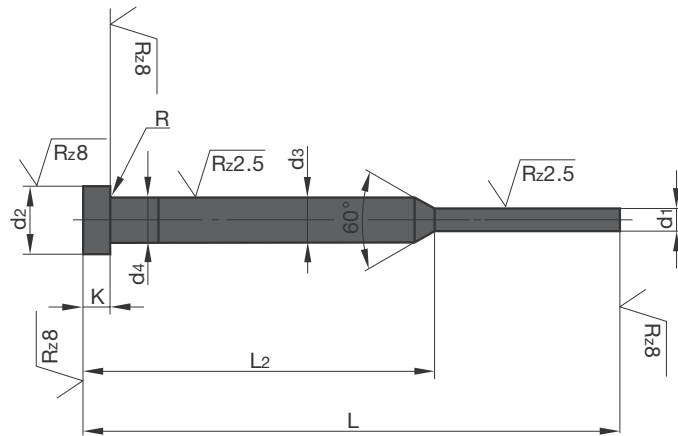

d1 g6	d2 0 -0,2	d3 g6	d4	k 0 -0,05	R +0,2 0	L +2 0			
						100	125	160	200
						L2 -1 -2			
						50	50	75	75
da 0,8 a 1,4	4	2	d1 + 0,03	2	0,2				
da 1,5 a 2,4	6	3		3	0,3				
da 2,5 a 2,9	6	3		3	0,3				

Altre misure a richiesta
 Other dimensions on request
 Autres dimensions sur
 demande
 Sonderabmessung auf Anfrage

Nitruati a richiesta
 Nitrided on request
 Nitrurés sur demande
 Nitriert auf Anfrage

Espulsori con testa cilindrica temprati a lamella
Blade ejectors hardened
Ejecteurs à lame trempés
Flachauswerferstifte gehärtet

BM
Industrie

DIN ISO 8693 FH

Acciaio
Steel
Acier
Werkstoff

WS

Durezza
Hardness
Durété
Härte

Gam bo: 60/62 HRC
 Testa: 45 ± 5 HRC

Shaft: 60/62 HRC
 Head: 45 ± 5 HRC

Cop: 60/62 HRC
 Tête: 45 ± 5 HRC

Schaft: 60/62 HRC
 Kopf: 45 ± 5 HRC

Esecuzione
Finish
Exécution
Ausführung

Temprati - Rettificati

Hardened - Ground

Trempés - Rectifiés

Gehärtet - Geschliffen

Testa riscalcata a caldo

The head is hot forged

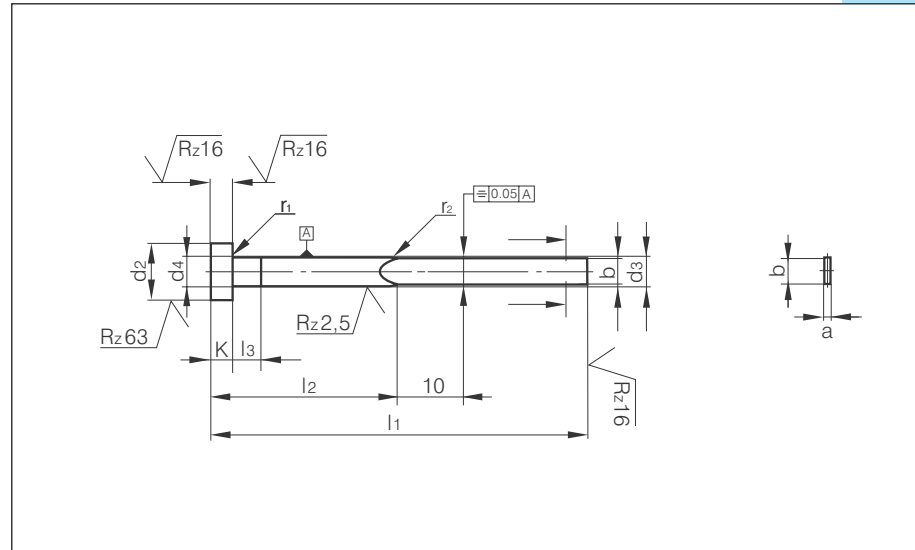

a	b	d ₃	d ₂	d ₄	k	n	m	l ₁ + 2 / 0										l ₃				
								l ₂ - 1 / 2														
								63	80	100	125	160	200	250	315	400						
0 -0,015	0 -0,015	0 -0,1	0 -0,2		0 -0,05	+0,2 0	m in															
1,0	3,5	4	8																			
0,8																						
1,0	3,8	4,2	8																			
1,2					3	0,3																5
1,0																						
1,2	4,5	5	10																			
1,5																						
1,0				d ₃ +0,03																		
1,2																						
1,5	5,5	6	12				10															6
2,0																						
1,2					5	0,5																
1,5	7,5	8	14																			8
2,0																						
1,5																						
2,0	9,5	10	16																			10
2,0																						
2,0				d ₃ +0,04																		
2,5	11,5	12	18		7	0,8																12

Altre misure a richiesta
 Other dimensions on request
 Autres dimensions sur demande
 Sondeabmessungen auf Anfrage

Nitratati a richiesta
 Nitrided on request
 Niturées sur demande
 Nitriert auf Anfrage

Espulsori con testa cilindrica nitrurati a lamella
Blade ejectors nitrided
Ejecteurs à lame nitrurés
Flachauswerferstifte nitriert

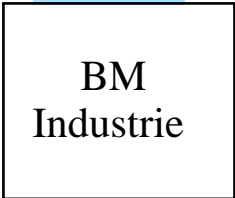

DIN ISO 8693 F

Acciaio
Steel
Acier
Werkstoff

1.2343

Durezza
Hardness
Durété
Härte

Gam bo: 60/62 HRC
 Testa: 45 ± 5 HRC

Shaft: 60/62 HRC
 Head: 45 ± 5 HRC

Corp: 60/62 HRC
 Tête: 45 ± 5 HRC

Schaft: 60/62 HRC
 Kopf: 45 ± 5 HRC

Esecuzione
Finish
Exécution
Ausführung

Nitrurati - Rettificati

Nitrided - Ground

Nitrurés - Rectifiés

Nitriert - Geschliffen

Testa ricalcata a caldo

The head is hot forged

Altre misure a richiesta
 Other dimensions on request
 Autres dimensions sur
 demande
 Sondeabmessungen auf Anfrage

Nitrurati a richiesta
 Nitrided on request
 Nitrurés sur demande
 Nitriert auf Anfrage

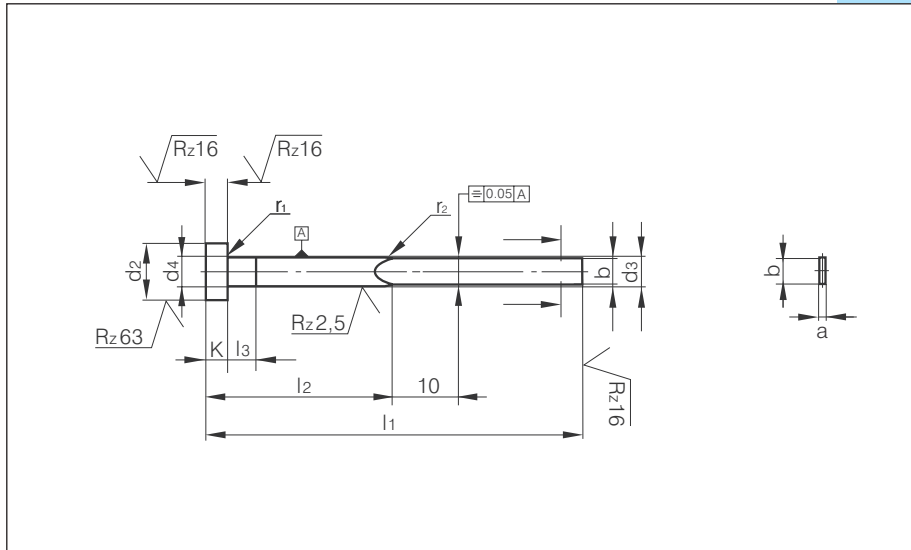

a	b	d ₃	d ₂	d ₄	k	r ₁	r ₂	l ₁ + 2 / 0										l ₃				
								l ₂ - 1 / 2														
								63	80	100	125	160	200	250	315	400						
0 -0,015	0 -0,015	0 -0,1	0 -0,2		0 -0,05	+0,2 0	m in															
1,0	3,5	4	8																			
0,8																						
1,0	3,8	4,2	8																			
1,2					3	0,3																5
1,0																						
1,2	4,5	5	10																			
1,5																						
1,0				d ₃ +0,03																		
1,2																						
1,5	5,5	6	12				10															6
2,0																						
1,2					5	0,5																
1,5	7,5	8	14																			8
2,0																						
1,5																						
2,0	9,5	10	16																			10
2,0				d ₃ +0,04																		
2,0																						
2,5	11,5	12	18		7	0,8																12

Espulsori con testa cilindrica temprati a lamella con 4 raggi d'angolo 0,2 mm
Blade ejectors hardened with 4 corner radiuses 0,2 mm
Ejecteurs à lame trempés avec 4 radions angulaires 0,2 mm
Flachauswerferstifte gehärtet mit 4 eckenradien 0,2 mm
DIN ISO 8693 FH

Acciaio
Steel
Acier
Werkstoff

W S

Durezza
Hardness
Dureté
Härte

Gamma bo: 60/62 HRC
 Testa: 45 ± 5 HRC

Shaft: 60/62 HRC
 Head: 45 ± 5 HRC

Corp: 60/62 HRC
 Tête: 45 ± 5 HRC

Schaft: 60/62 HRC
 Kopf: 45 ± 5 HRC

Esecuzione
Finish
Exécution
Ausführung

Temprati - Rettificati

Hardened - Ground

Trempés - Rectifiés

Gehärtet - Geschliffen

Testa ricalcata a caldo

The head is hot forged

Altre misure a richiesta
 Other dimensions on request
 Autres dimensions sur demande
 Sonderabmessungen auf Anfrage

Nitrurati a richiesta
 Nitrided on request
 Nitrurées sur demande
 Nitriert auf Anfrage

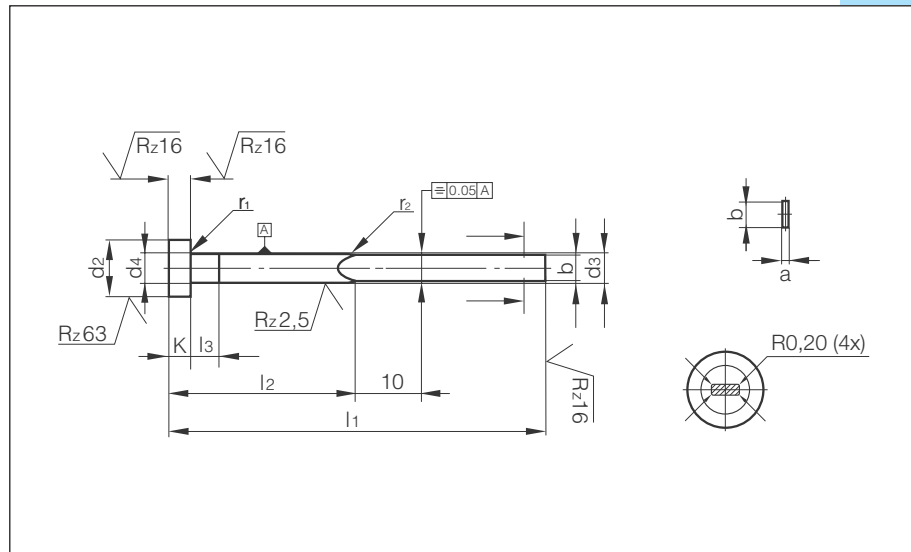

a	b	d ₃	d ₂	d ₁	K	r ₁	r ₂	l ₁ + 2 / 0								l ₃	
								63	80	100	125	160	200	250	315		
								l ₁ - 1 / 2									
0	0	0	0	0	0	0	0	32	40	50	63	80	100	125	160		
1,0	3,5	4	8														
0,8																	
1,0	3,8	4,2	8														
1,2					3	0,3											5
1,0																	
1,2	4,5	5	10														
1,5																	
1,0				d ₃													
1,2				+0,03													
1,5	5,5	6	12				10										
2,0																	
1,2					5	0,5											
1,5	7,5	8	14														
2,0																	8
1,5																	
2,0	9,5	10	16	d ₃													
				+0,04													10

Bussole di espulsione temprate
Ejector Sleeves hardened
Éjecteurs tubulaires trempés
Auswerferhülsen gehärtet

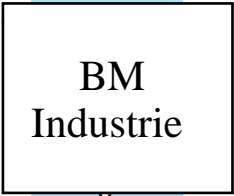

DIN ISO 8405

Acciaio
Steel
Acier
Werkstoff

W S

Durezza
Hardness
Dureté
Härte

Gam bo: 60/62 HRC
 Testa: 45 ± 5 HRC

Shaft: 60/62 HRC
 Head: 45 ± 5 HRC

Copp: 60/62 HRC
 Tête: 45 ± 5 HRC

Schaft: 60/62 HRC
 Kopf: 45 ± 5 HRC

Esecuzione
Finish
Exécution
Ausführung

Temprati - Rettificati

Hardened - Ground

Trempés - Rectifiés

Gehärtet - Geschliffen

Testa ricalcata a caldo

The head is hot forged

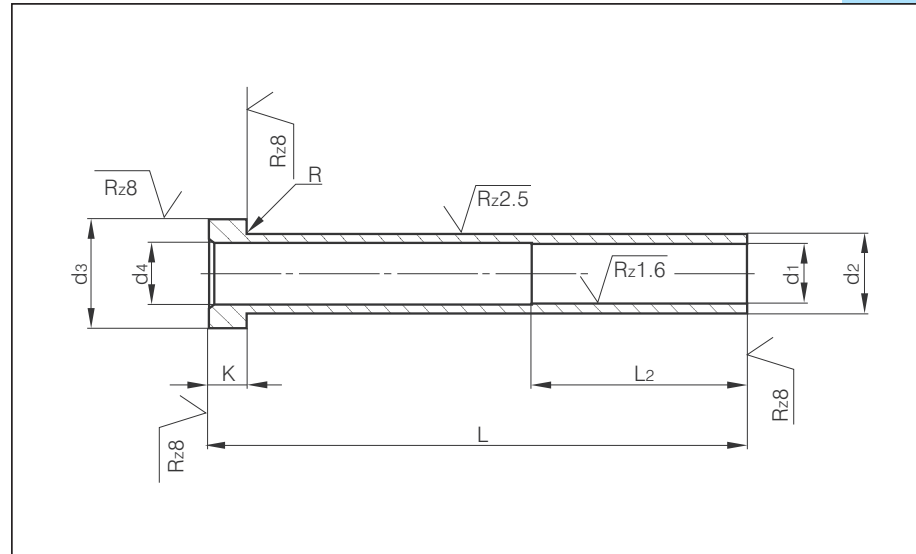

d1 H5	d2 g6	d4	d3 0 -0,2	k 0 -0,05	R +0,2 0	I2 +2 0	L ₁									
							75	100	125	150	175	200	225	250		
1,5	3	2	6	3	0,3	35										
1,6																
2	4	2,4	8													
2,2		2,6														
2,5	5	2,9	10													
2,7		3														
3		3,4														
3,2		3,6														
3,5		3,9														
3,7	6	4	12				5	0,5	45							
4		4,4														
4,2		4,6														
5	8	5,4	14													
5,2		5,6														
6		6,4														
6,2	10	6,6	16													
8		8,4														
8,2	12	8,6	20													
10		10,4														
10,5	14	11	22	7	0,7											
12		12,4														
12,5	16	13														

Bussole di espulsione nitrurate lucide
Ejector Sleeves nitrided polished
Éjecteurs tubulaires nitrurés polis
Auswerferhülsen nitriert blank

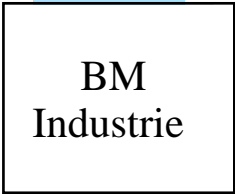

DIN ISO 8405

Acciaio
Steel
Acier
Werkstoff

1,2344

Durezza
Hardness
Dureté
Härte

Gam bo: 65+2 HRC
 Testa: 50 - 5 HRC

Shaft: 65+2 HRC
 Head: 50 - 5 HRC

Comp: 65+2 HRC
 Tete: 50 - 5 HRC

Schaft: 65+2 HRC
 Kopf: 50 - 5 HRC

Esecuzione
Finish
Exécution
Ausführung

Nitrati - Rettificati

Precision ground - Lapped - Nitrided

Nitrurés - Rectifiés

Nitriert - Geschliffen

Testa ricabata a caldo

The head is hot forged

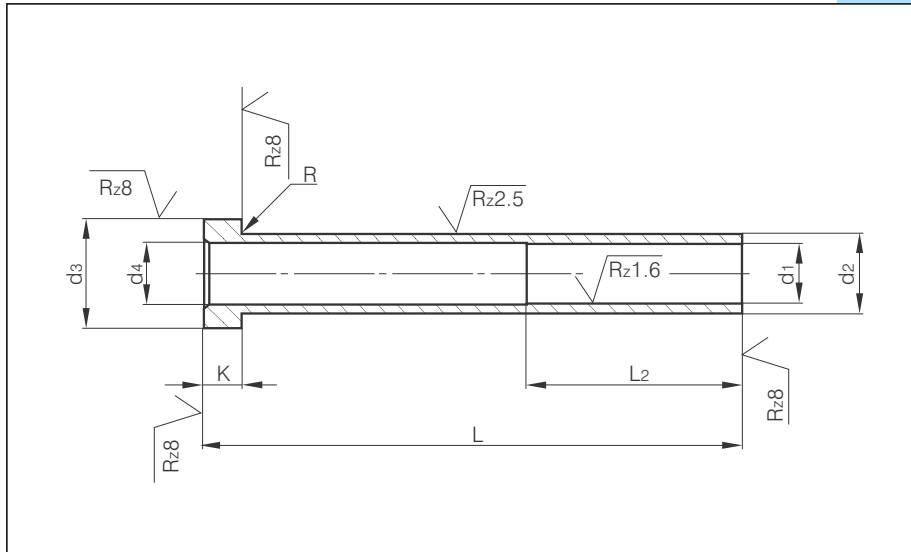

d1 H5	d2 g6	d4	d3 0 -0,2	k 0 -0,05	R +0,2 0	I2 +2 0	L ±1													
							75	100	125	150	175	200	225	250						
1,5	3	2	6	3	0,3	35														
1,6																				
2	4	2,4	8																	
2,2							2,6													
2,5	5	3	10																	
2,7							2,9													
3				3																
3,2				3,4																
3,5	6	4	12																	
3,7				2,6																
4				2,9																
4,2	8	3	14	5	0,5	45														
4,2							3,6													
5							3,9													
5,2	4,2																			
6	4,4																			
6,2	4,6																			
8	10	4	16																	
8				5,4																
8,2				5,6																
10	12	3	20	7	0,7															
10							5,8													
10	6,2																			
12	6,4																			
12	6,6																			
12	6,8																			

Colonne per stampi plastica
Guide pillars for plastic moulds
Colonnes de guidage
Abstreiferführungssäulen

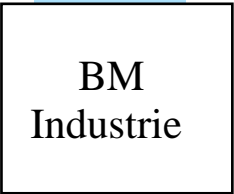

Tipo 32P

Acciaio
Steel
Acier
Werkstoff

1.7131

Durezza
Hardness
Durété
Härte

60-62 HRC

Esecuzione
Finish
Exécution
Ausführung

Cem entate - tem plate -
 rinvenute - rectificate

Case hardened - hardened
 throughout - annealed and
 ground

Tem pés - Cem entés - revenues
 et rectifiées

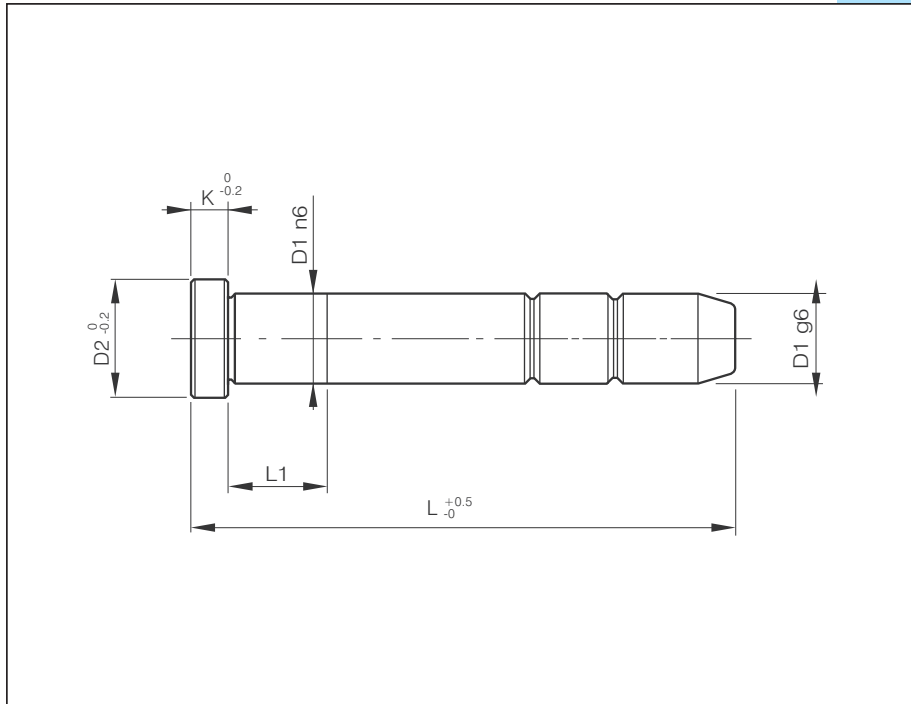

D1	D2	K	L=	50	60	70	80	90	100	110	120	130	140	150	160	180	200	220	240	260	280	300	350	400	450	500	600	800	
				L1=	8	8	8	15	15	20	20	20	20	20	20	20	25	25	25	30	30	30	30	45	55	55	65	65	75
12	16	5																											
14	18	5																											
16	20	5																											
18	22	5																											
20	24	6																											
25	30	7																											
32	37	7																											
40	45	8																											
50	55	10																											
60	68	12																											

Altre dimensioni a richiesta
 Other measures on request
 Autres dimensions sur
 demande

Colonne per stampi plastica
Guide pillars for plastic moulds
Colonnes de guidage
Führungssäulen

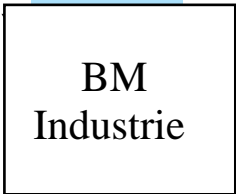

Tipo 33 PT

Acciaio
Steel
Acier
Werkstoff

1.7131

Durezza
Hardness
Dureté
Härte

60-62 HRC

Esecuzione
Finish
Exécution
Ausführung

Cem entate - tem plate -
 rinvenute - rectificate

Case hardened - hardened
 throughout - annealed and
 ground

Tem pés - Cem entés - revenues
 et rectifiées

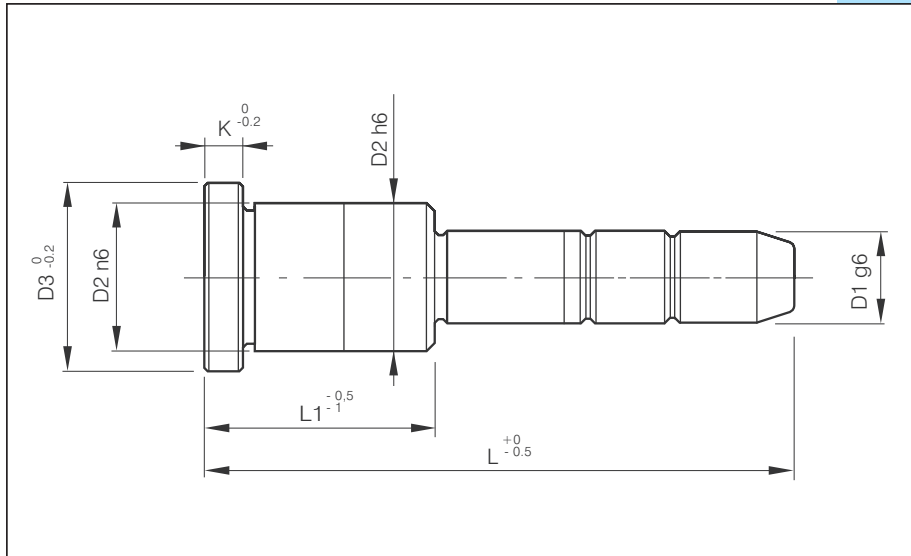

D ₁	D ₂	D ₃	K	L ₁	50	60	70	80	90	100	120	140	160	180	200	220	240	260	280	300	340					
12	18	22	5	22																						
				26																						
				36																						
				46																						
				56																						
14	20	24	5	22																						
				26																						
				36																						
				46																						
				56																						
16	22	26	5	22																						
				26																						
				36																						
				46																						
				56																						
				66																						
				76																						
18	26	30	5	26																						
				36																						
				46																						
				56																						
				66																						
20	28 30	32 34	6	26																						
				36																						
				46																						
				56																						
				66																						
				76																						
				86																						
				96																						

Colonne per stampi plastica
Guide pillars for plastic moulds
Colonne de guidage moules
Führungssäulen

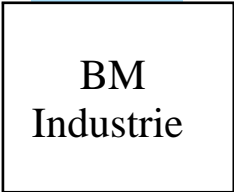

Tipo 33 PT

Acciaio
Steel
Acier
Werkstoff

1.7131

Durezza
Hardness
Dureté
Härte

60-62 HRC

Esecuzione
Finish
Exécution
Ausführung

Cem entate - tem plate -
 invenute - rectificate

Case hardened - hardened
 throughout - annealed and
 ground

Tem pés - Cem entés - revenues
 et rectifiées

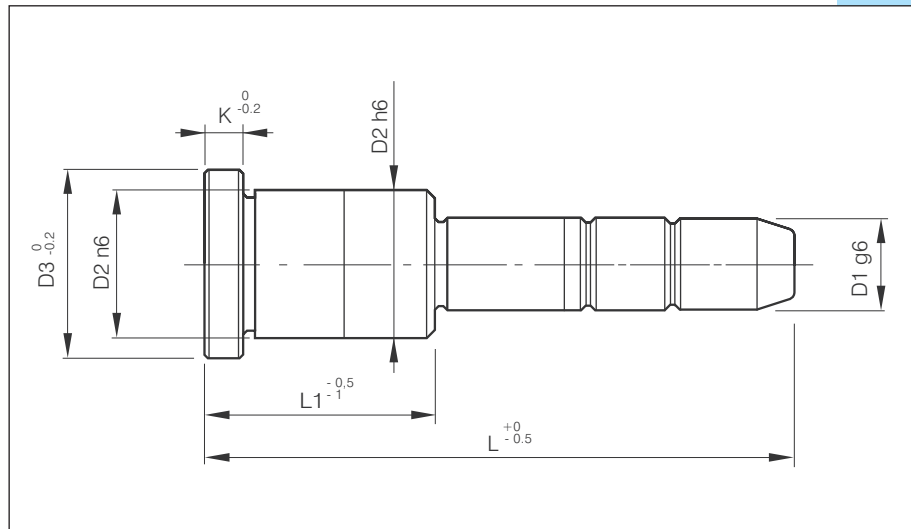

D1	D2	D3	K	L1	60	70	80	90	100	120	140	160	180	200	220	240	260	280	300	340	400					
25	34	38	7	36	26																					
					36																					
					46																					
					56																					
					66																					
					76																					
					86																					
					96																					
					116																					
32	40	45	7	45	36																					
					46																					
					56																					
					66																					
					76																					
					86																					
					96																					
					106																					
					116																					
40	48	52	8	52	46																					
					56																					
					66																					
					76																					
					86																					
					96																					
					106																					
					116																					
					126																					
50	60	65	10	65	96																					
					126																					
					146																					

Colonne per stampi plastica
Guide pillars for plastic moulds
Colonnes de guidage
Führungssäulen mit Bund

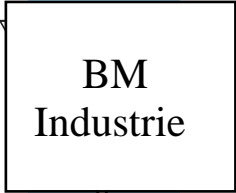

Tipo PTR

Acciaio
Steel
Acier
Werkstoff

1.7131

Durezza
Hardness
Dureté
Härte

60-62 HRC

Esecuzione
Finish
Exécution
Ausführung

Cem entate - tem prate -
rettificate

Case hardened - hardened
throughout - annealed and
ground

Cem entés - tem pés - revenues
et rectifiées

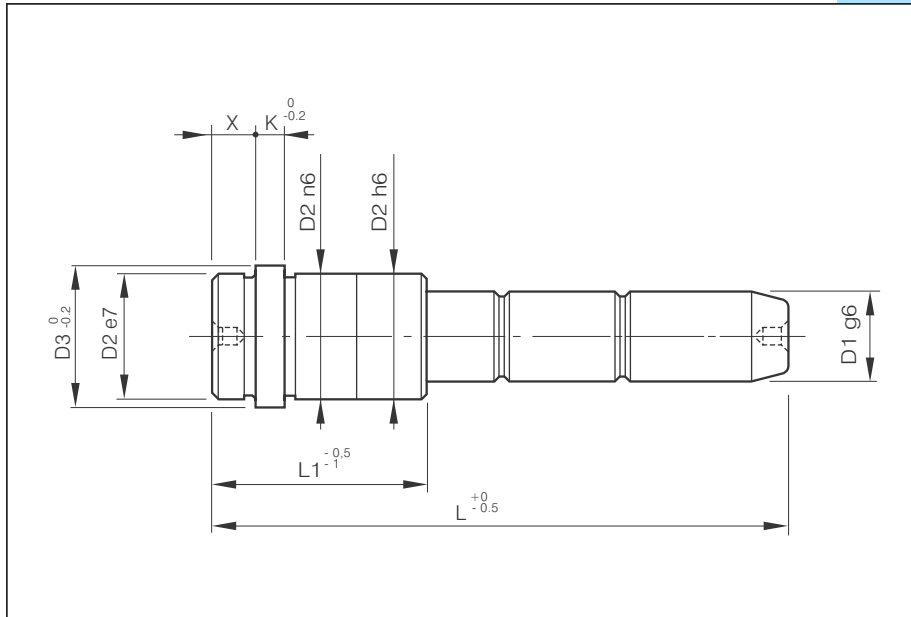

D1	D2	D3	K	X	L1	L = lunghezza totale								
						80	90	110	130	150	170	190	210	
16	22	26	5	10	36									
					46									
					56									
					66									
					76									
20	28 30*	32 34*	6	10	46									
					56									
					66									
					76									
					86									
25	34 36*	38 40*	7	10	46									
					56									
					66									
					76									
					86									
32	40	45	7	10	46									
					56									
					66									
					76									
					86									
40	48	52	8	10	56									
					66									
					76									
					86									
					106									

* A richiesta
On request
Sur demande
Auf Anfrage

Bussole di guida
Guide bushes
Bagues de guidages lisses
Führungsbuchsen

BM
Industrie

Tipo PA

Acciaio
Steel
Acier
Werkstoff

1.7131

Durezza
Hardness
Durété
Härte

60-62 HRC

Esecuzione
Finish
Exécution
Ausführung

Cem entate - tem plate -
 rettificata - lappate

Case hardened - hardened
 throughout - annealed and
 ground

Cem entés - tem pés - revenues
 et rectifiées

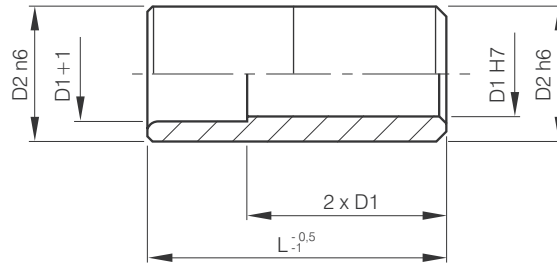

D1	D2	L= LUNGHEZZA m m .																
		22	26	36	46	56	66	76	86	96	106	116	126	136	146	156	176	196
12	18																	
14	20																	
16	22																	
18	26																	
20	28/30*																	
25	34/36*																	
32	40																	
40	48																	

* A richiesta
 On request
 Sur demande
 Auf Anfrage

**Bussole con collare
per stampi plastica
Headed guide bushes
Bagues à collerette
Führungsbuchsen mit Bund**

Tipo 38 PB

**Acciaio
Steel
Acier
Werkstoff**

1.7131

**Durezza
Hardness
Dureté
Härte**

60-62 HRC

**Esecuzione
Finish
Exécution
Ausführung**

Cem entate - tem prate -
rettificate - lappate

Case hardened - hardened
throughout - annealed and
ground

Cem entés - tem pés - revenues
et rectifiées

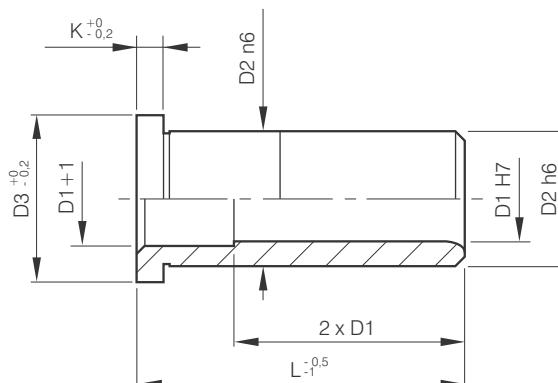

D1	D2	D3	K	L																
				22	26	36	46	56	66	76	86	96	106	116	126	136	146	156	176	196
12	18	22	5																	
14	20	24	5																	
16	22	26	5																	
18	26	30	5																	
20	30*/28	34*/32	6																	
25	36*/34	40*/38	7																	
32	40	45	7																	
40	48	52	8																	
50	60	65	10																	
60	74	84	12																	

A richiesta: si eseguono
bussole PB in bronzo

On request: in bronze

Sur demande: en bronze

Auf Anfrage: in Bronze

Bussole spallate
Shouldered bushes
Bagues de guidage epaulées
Führungsbuchsen mit Bund und Ansatz

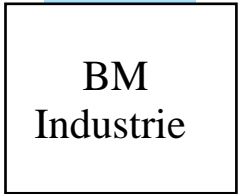

Tipo PR

Acciaio
Steel
Acier
Werkstoff

1.1731

Durezza
Hardness
Dureté
Härte

60-62 HRC

Esecuzione
Finish
Exécution
Ausführung

Cementate - tempered -
 rectified

Case hardened - hardened
 throughout - annealed and
 ground

Cementés - trem pés - revenues
 et rectifiées

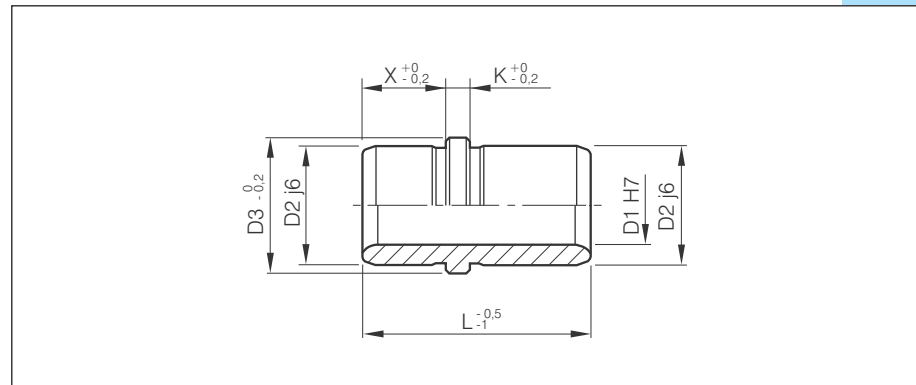

D1	D2	D3	X	K	L	
12	18	22	16	5	32	40
14	20	24	16	5	32	40
16	22	26	16	5	32	40
18	26	30	16	5	32	40
20	28/30*	32/34*	16	6	32	40
25	34/36*	38/40*	16	7	32	40
32	40	45	25	7	50	65
40	48	52	32	8	65	80
50	60	65	32	10	70	90

Bussole spallate bronzo integrale
Shouldered bushes in bronze
Bagues de guidage epaulées en bronze
Führungsbuchsen mit Bund und Ansatz aus Bronze

Tipo PR BRONZO

Materiale
Material

Bronzo
 Bronze
 Bronze
 Bronze

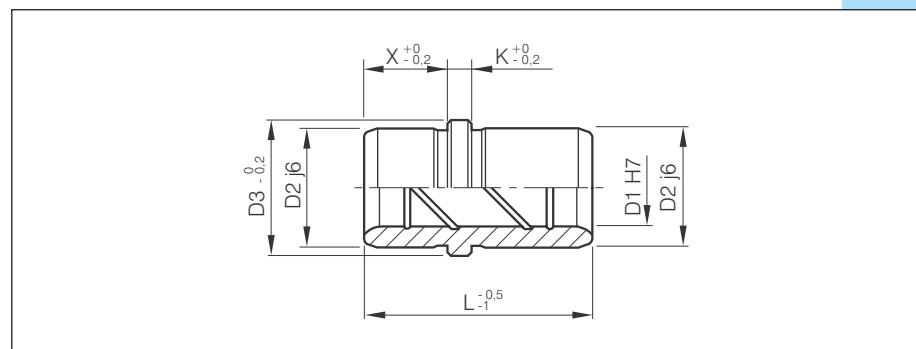

D1	D2	D3	X	K	L	
12	18	22	16	5	32	40
14	20	24	16	5	32	40
16	22	26	16	5	32	40
18	26	30	16	5	32	40
20	28/30*	32/34*	16	6	32	40
25	34/36*	38/40*	16	7	32	40
32	40	45	25	7	50	65
40	48	52	32	8	65	80
50	60	65	32	10	70	90

* A richiesta
 On request
 Sur demande
 Auf Anfrage

Bussole di guida
Headed guide bushes
Bagues à collerette
Führungsbuchsen mit Bund

BM
Industrie

Tipo PBR

Acciaio
Steel
Acier
Werkstoff

1.7131

Durezza
Hardness
Durété
Härte

60-62 HRC

Esecuzione
Finish
Exécution
Ausführung

Cementate - tem prate -
 rettificata

Case hardened - hardened
 throughout - annealed and
 ground

Cementés - tem pés - revenues
 et rectifiées

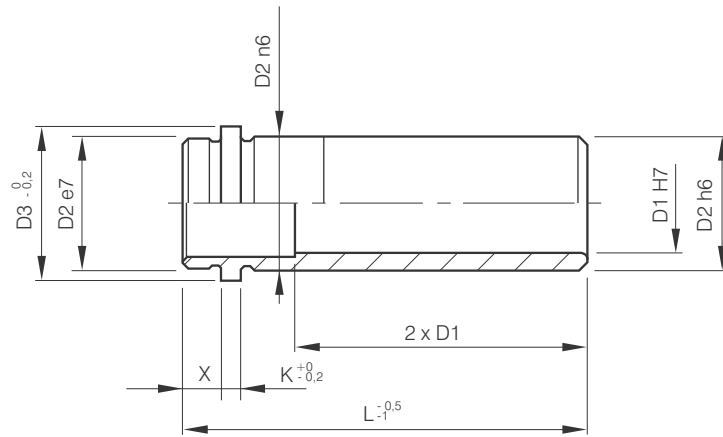

D1	D2	D3	K	X	L = lunghezza totale											
					26	36	46	56	66	76	86	96	106	124		
16	22	26	5	10												
20	28/30*	32/34*	6	10												
25	34/36*	38/40*	7	10												
32	40	45	7	10												
40	48	52	8	10												

* A richiesta
 On request
 Sur demande
 Auf Anfrage

Bussole iniezione per stampi plastica
Sprue bushings
Buses d'injection
Angussbuchsen

BM
Industrie

Acciaio
Steel
Acier
Werkstoff

38 NCD4

Durezza
Hardness
Dureté
Härte

50-55 HRC

Esecuzione
Finish
Exécution
Ausführung

Temprate - non temprate -
 rettificati
 Hardened - not hardened -
 ground
 Trèm pès - pas trèm pès -
 Rectifiés
 Gehärtet - nicht gehärtet -
 Geschliffen
 Foro conico 1°50'

A richiesta in **isura fuori**
catalogo

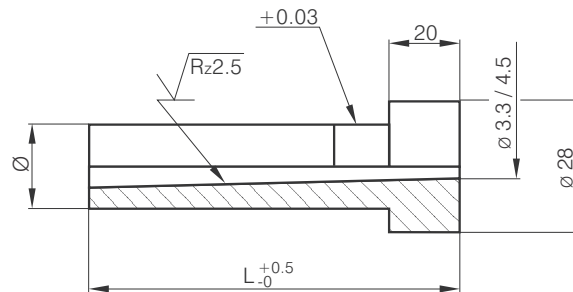

Ø	L	non temprate	temprate
Ø mm . 14/18	50		
Ø mm . 14/18	65		
Ø mm . 14/18	75		
Ø mm . 14/18	85		
Ø mm . 14/18	95		
Ø mm . 14/18	105		
Ø mm . 14/18	115		
Ø mm . 14/18	125		
Ø mm . 14/18	135		
Ø mm . 14/18	150		

Acciaio
Steel
Acier
Werkstoff

16 NCR 4

Durezza
Hardness
Dureté
Härte

60-62 HRC

Esecuzione
Finish
Exécution
Ausführung

Temprati - non temprati -
 rettificati
 Hardened - not hardened -
 ground
 Trèm pès - pas trèm pès -
 Rectifiés
 Gehärtet - nicht gehärtet -
 Geschliffen

Piedini appoggio tavolino
Stop pins
Butées de course d'ejection
Anschlage

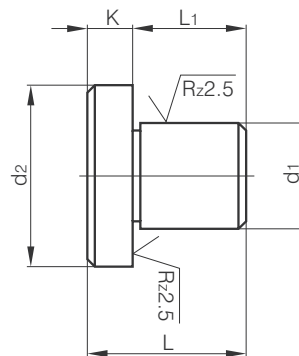

d1	d2	K	L	L1
8	16	5	17	12
14	24	6	21	15

Centraggi conici
Locating elements
Plots de centrage
Zentriereinheiten

BM
Industrie

● **Normalizzazione Europea - Euro Norm**

Acciaio
Steel
Acier
Werkstoff

16 CR N14

Esecuzione
Finish
Exécution
Ausführung

Cementato - tem piato - rettificato

Case hardened - hardened throughout - ground

Tem pòs - cem entòs - rectificòes

Geh retet - Geschliffen

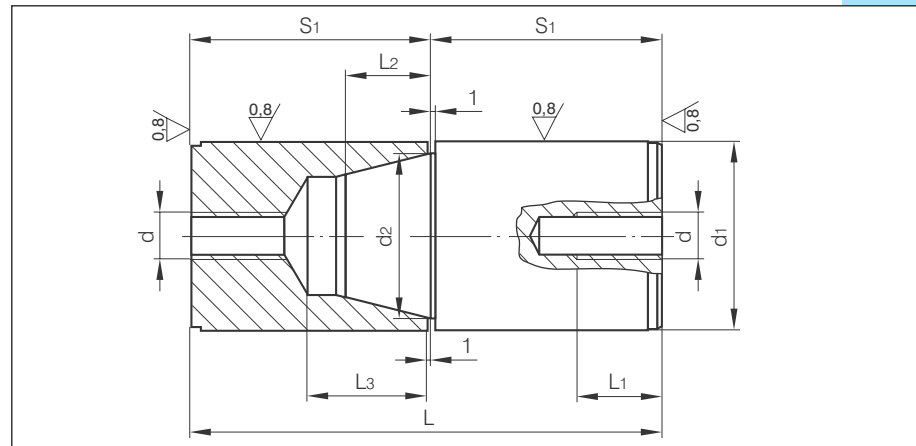

	d	d-1	d-2	L-1	L-2	L-3	S1	L
● M 5	14	9	9	12	6	8	16	34
M 5	16	10	10	12	6	8	24	50
● M 5	16	9	9	12	6	8	16	34
● M 8	20	14	14	15	10	13	26	54
M 8	20	15	15	15	9	13	31	64
● M 8	25	18.5	18.5	15	10	13	26	54
● M 8	26	18.5	18.5	15	10	13	26	54
M 8	25	20	20	15	10	13	31	64
● M 10	30	23.5	23.5	18	14	20	35	72
M 10	32	25	25	18	14	20	39	80
● M 10	32	23.5	23.5	18	14	20	35	72
● M 10	40	31.5	31.5	18	17	25	45	92
M 10	40	35	35	18	18	25	48	100
● M 10	42	33.5	33.5	18	17	25	45	92

Anelli di centraggio
Locating rings
Bagues de centrage
Zentrierscheiben

Acciaio
Steel
Acier
Werkstoff

C40

Esecuzione
Finish
Exécution
Ausführung

Tombo - Tuned
 Deco - Gedreht

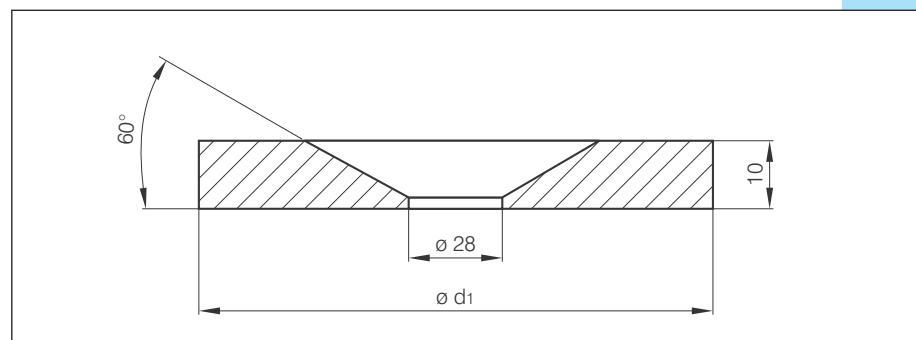

d1	60	70	80	90	100	125	150	175
----	----	----	----	----	-----	-----	-----	-----

Unità di centraggio
Centering elements
Plots de centrage
Zentriereinheiten

BM
Industrie

Acciaio
Steel
Acier
Werkstoff

1,2767

Durezza
Hardness
Dureté
Härte

52-54 HRC

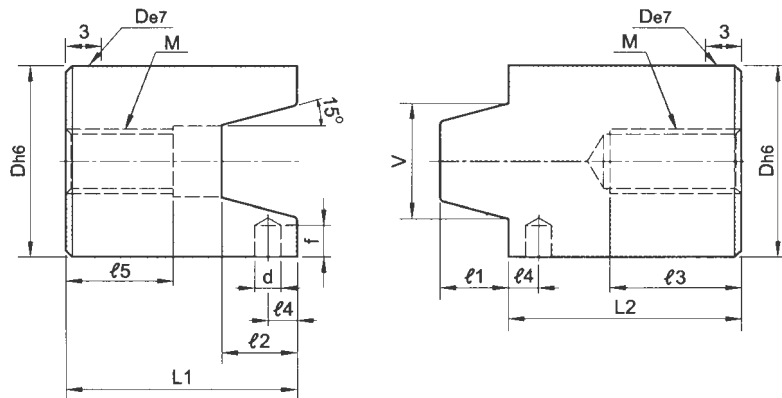
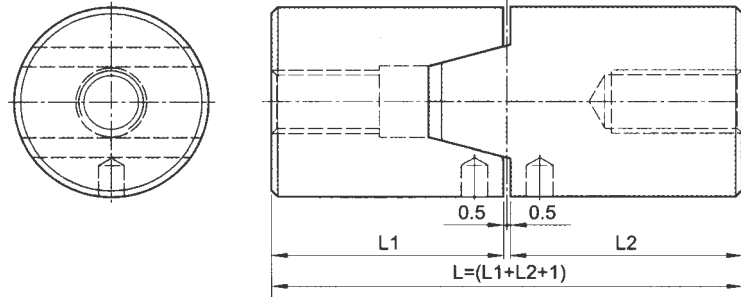

D g6	L	d H7	V	L1	L2	l1	l2	l3	l4	l5	f	M	
30	72	4	18	35,5	35,5	10,5	11,5	20	4,5	16,5	5	M 10	
42	92	5	23	45,5	45,5	14,5	15,5	20	5,5	18,5	7	M 10	
54	112	6	30	55,5	55,5	17,5	18,5	25	7,5	20,5	8	M 12	
80	152	8	42	75,5	75,5	27,5	28,5	30	7,5	25,5	11	M 16	

Centratori laterali
Side interlocks
Plots de centrage lateral
Zentriereinheit

BM
Industrie

Acciaio
Steel
Acier
Werkstoff

1,7131

Durezza
Hardness
Dureté
Härte

Maschio: 50-52 HRC
 Femmina: 50-52 HRC

Male: 50-52 HRC
 Female: 50-52 HRC

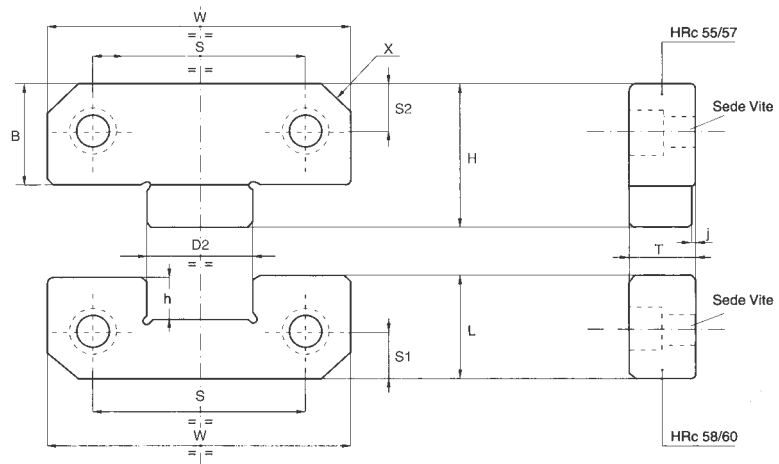
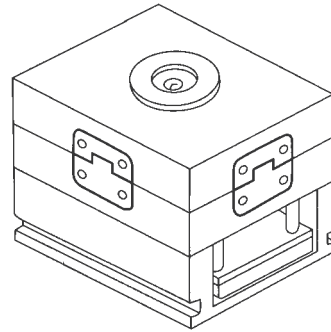

W	T 0 -0.01	L	B	h	D1	D2 +0.010 +0.005	H 0 -0.005	S	S1	S2	X	Sede vite	
38	13	22	22	8,5	12	12	30	22	7	7	5	5	
50	16	21,5	21,5	9,5	17	17	30	34	11	11	5	5	
75	19	36	36	15	25	25	50	50	18	18	8	8	
100	19	45	45	21	35	35	65	70	22	22	10	10	
125	25	45	45	21	45	45	65	84	22	22	10	10	

Blocco di centraggio
Taper block
Blocs de centrage
Zentriereinheit

BM
Industrie

Acciaio
Steel
Acier
Werkstoff

16 CR NI 4

Durezza
Hardness
Dureté
Härte

58-60 HRC

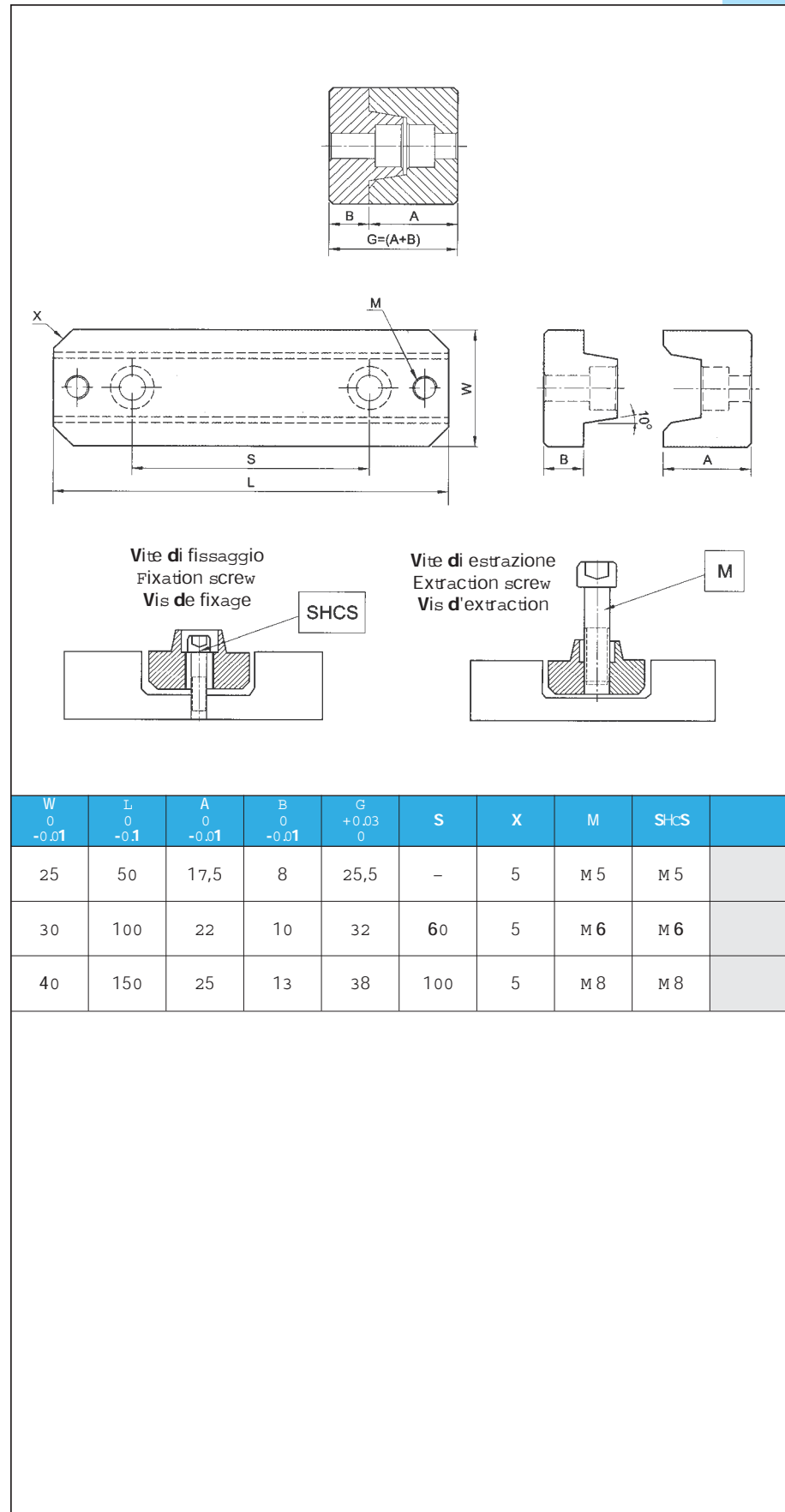

Datari per plastica e pressofusione annuali e mensili annuali con inserti filettati smontabili anteriormente tipo KR
Daters for plastic and pressure die casting type KR
Dateurs pour plastique et injection de metal type KR
Datum-Stempel für Kunststoff und Metal Spritzwerkzeuge type KR



Materiale
Material
Material
Werkstoff

Acciaio inox
 Stainless steel
 Acier Inoxydable
 Rostbeständiger Stahl

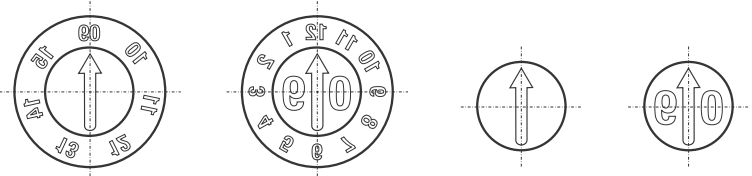

DAF-T DMAF-T IF-T IFA-T

DIMENSIONE DATARIO					DIMENSIONI INSERTO DATARIO						
D	L	E	M	F	A	L	R	T	E	S	M
6	8	0,20	1,6 x 0,2	3,10	3,10	7,50	2,50	3,30	1,6	2	1,6
8	10	0,25	2,3 x 0,25	4,40	4,40	9,50	4	3,80	2,30	2,50	2,3
10	12	0,35	2,5 x 0,35	5,20	5,20	11,50	4,50	4,30	2,50	3	2,5
12	14	0,35	3 x 0,35	6,20	6,20	13,50	5	5,80	3	3	3
16	14	0,35	4 x 0,35	8,20	8,20	13,50	5	5,80	4	3,50	4
20	16	0,35	4 x 0,35	11	11	15	5	6,30	4	4,50	4

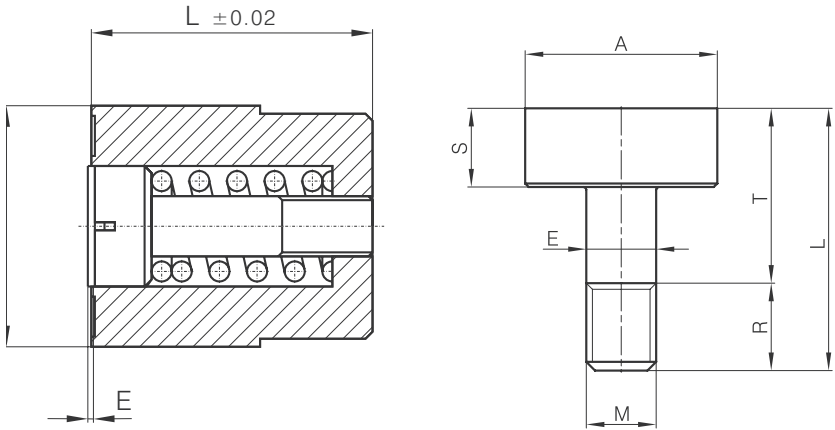

Valvole compensazione
Air Valve
Soupape de compensation
Luftventile

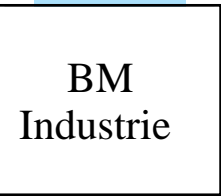

CodVKT

Materiale
Material
Material
Werkstoff

Acciaio inox
 Stainless steel
 Acier Inoxydable
 Rostbeständiger Stahl

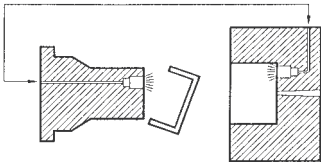

Vengono im piegate per com -
 pensare il vuoto durante la
 fase di estrazione in cavità
 profonde o per im m ettere aria.
 Costruite interam ente in acciaio
 inox, tem perate e rettificata,
 con dado autobloccante.

The valves are used to
 com pensate the vacuum
 during extraction from deep
 cavities or to let air in. They are
 m ade entirely in stainless steel,
 hardened and ground, with
 selflocking nut.

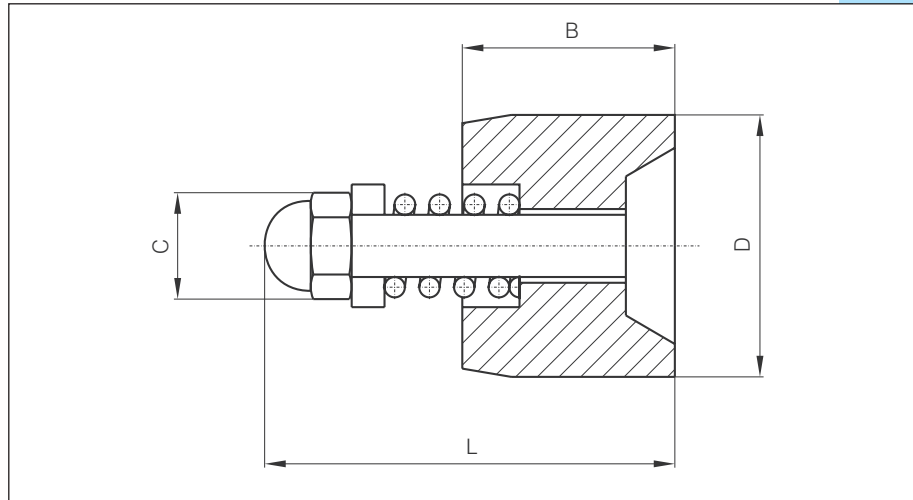

Cod.	D	B	C	L
VKT08	8	11	7	28
VKT10	10	11	7	31
VKT12	12	18	9	31
VKT16	16	20	10	43
VKT18	18	22	12	43
VKT20	20	20	12	43
VKT25	25	20	12	63

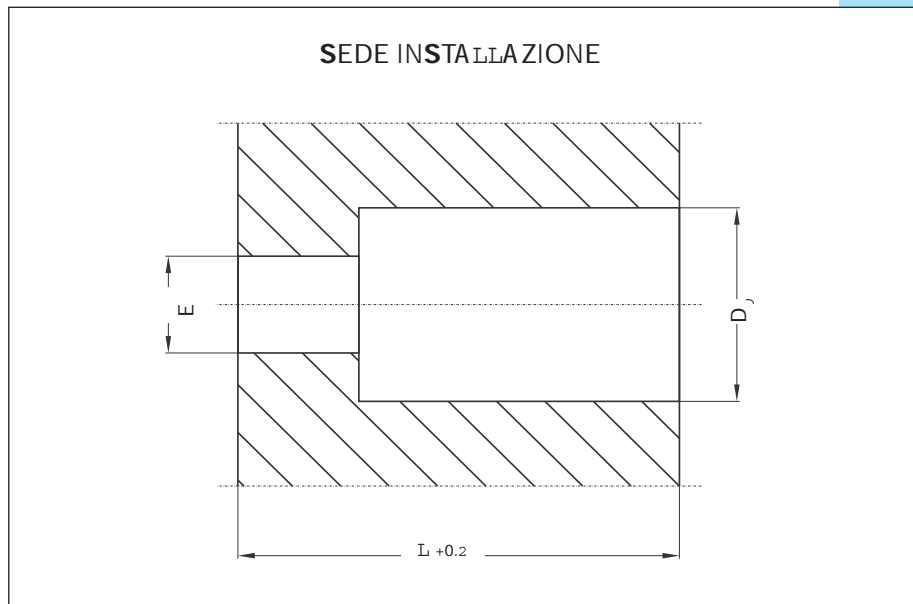

Cod.	D	L	E
VKT08	8	11	7
VKT10	10	11	8
VKT12	12	18	10
VKT16	16	20	12
VKT18	18	22	14
VKT20	20	20	14
VKT25	25	20	14

Valvole di compensazione
Air Valve
Soupape de compensation
Luftventile

BM
Industrie

Cod VKTB

Materiale
Material
Material
Werkstoff

Acciaio inox
 Stainless steel
 Acier Inoxydable
 Rostbeständiger Stahl

Vengono impiegate per compensare il vuoto durante la fase di estrazione in cavità profonde o per immettere aria. Costruite interamente in acciaio inox, temperate e rettificate, con dado autobloccante.

The valves are used to compensate the vacuum during extraction from deep cavities or to let air in. They are made entirely in stainless steel, hardened and ground, with selflocking nut.

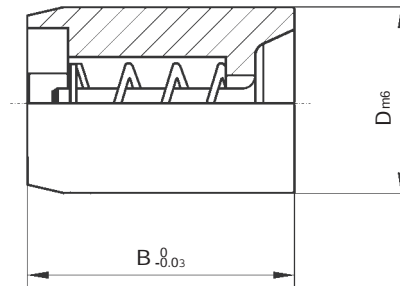

Cod.	D	B
VKTB 08	8	14
VKTB 10	10	14
VKTB 12	12	18
VKTB 16	16	20
VKTB 18	18	22
VKTB 20	20	20
VKTB 26	26	20

SEDE INSTALLAZIONE

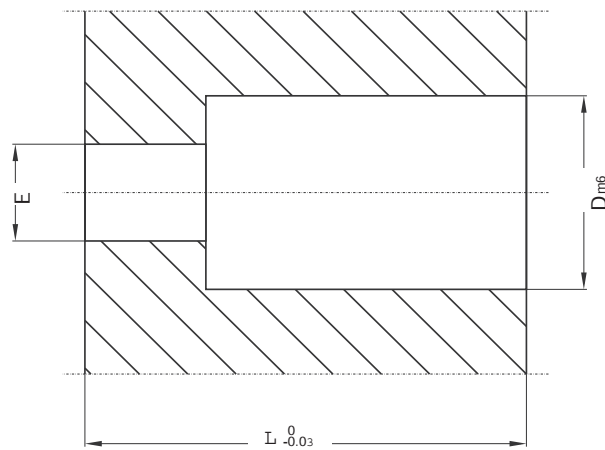



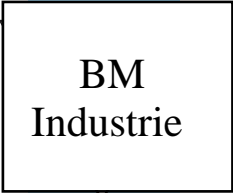

Cod.	D	L	E
VKTB 08	8	14	5
VKTB 10	10	14	8
VKTB 12	12	18	8
VKTB 16	16	20	8
VKTB 18	18	22	8
VKTB 20	20	20	16
VKTB 26	26	20	18

Marchi riciclaggio
Recycling insert
Inserts de recyclage
Recycling-Stempel

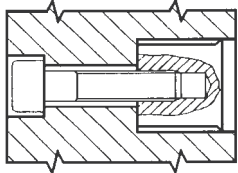

Materiale
Material
Material
Werkstoff

Acciaio inox
 Stainless steel
 Acier Inoxydable
 Rostbeständiger Stahl

M R N	M R C	M R S	
			
SI BOLO NE TR O NE TRALS BOL	SI BOLO E CODICE S BOL AND CODE	SI BOLO CODICE E SI LA / S BOL CODE AND AR	

I marchi di riciclaggio hanno lo scopo di contrassegnare, con precisione, i manufatti provenienti dalla lavorazione delle materie plastiche. Il marchio, conforme alla simbologia unificata DIN 6120 e alla sigla normalizzata ISO 1043-1, facilita il riconoscimento dei materiali da inviare alla rottamazione.

Recycling marks are meant to precisely distinguish handworks coming from plastic materials processing. The mark, complying with the unified DIN 1043-1 symbology, allows to easily identify the materials to be scrapped.

INSTALLAZIONE

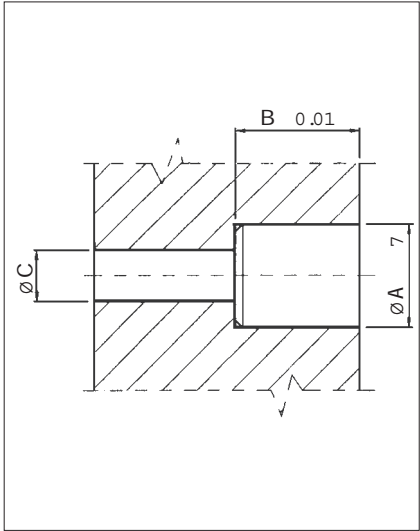

MARCHI DI RICICLAGGIO			
Dimensioni / Dimensions	A	B	C
Marchio ø 10 / Diam 10 mark	10	12	4,5
Marchio ø 16 / Diam 16 mark	16	14	7
Marchio ø 20 / Diam 20 mark	20	16	10

CODICE CODE	SIGLA MARK	DENOMINAZIONE DENOMINATION
01	PET	OLIE TEREFTALATO Tere thate - o eth ene
02	PE-HD	OLIE TENE ALTA DENSIT igh-densit o eth ene
03	PVC	OLIE LORO DI VINILE Vin o Chloride
04	PE-LD	OLIE TENE BASSA DENSIT Low-densit o eth ene
05	PP	OLIE RILENE o ro ene
06	PS	OLIE STIROLO o st rene
	ABS	TERMOPOLIMERO ACRILON BUTAD. STIROLO Therm o mer Acr onitrie- utadiene-st rene
		ALIMENTI Food
	PA	NILON N on
	POM	OLIE ACETATO o -acetate
	PPO	OLIE FENIL-OSSIDO o feni -Oxide
	PC	OLIE CARBONATO o car onate
		NE TR O Neutra

Valvole e raccordi-rapidi
Water connectors
Coupler rapide
Schnellkupplung

BM
Industrie

Acciaio
Steel
Acier
Werkstoff

Ottone
 Brass
 Laiton
 Messing

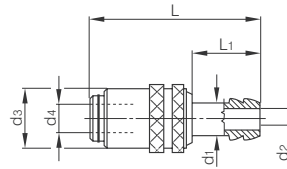

ATTACCO RAPIDO	d4	d2	d1	d3	L	L1
VALVOLA R R 6	10	6	10	18	49	18
VALVOLA R R 9	14	9	14	24	61	25

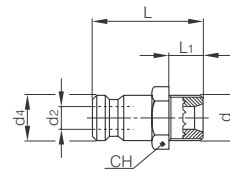

RACCORDI	d	d2	d4	L1	L	CH
INNESTO I R 6	1/8" GAS	6	9	8	28	13
INNESTO I R 6	1/4" GAS	6	9	8	28	13
INNESTO I R 6	M 10	6	9	8	28	13
INNESTO I R 9	1/4" GAS	9	13,5	10,5	28	14

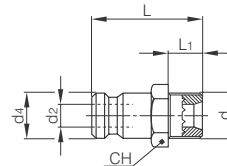

Tipo EUROPEO	d	d2	d4	L1	L	CH
ER	1/4" GAS	6	9,5	9	24	14
ER	1/8" GAS	6	9,5	9	24	14
ER	1/4" GAS	9	13,5	12,5	34	14
ER	1/8" GAS	9	13,5	12,5	34	14

Acciaio
Steel
Acier
Werkstoff

Ottone
 Brass
 Laiton
 Messing

Tappi conici con esagono incassato
Taper threaded plugs
Bouchons filetés coniques
Könische Verschluss-Schrauben

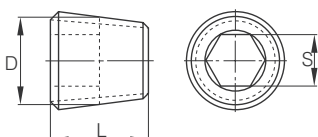

DGas	L	S
1/8" GAS	9,78	3/16"
1/4" GAS	12,9	1/4"
3/8" GAS	14,5	5/16"
1/2" GAS	17,7	3/8"

Raccordi per stampi con esagono esterno
Hose extension exagonal exterior
Raccord mouliste avec extern exagonal
Anschlußnippel mit Äußere Sechskant

BM
Industrie

Acciaio
Steel
Acier
Werkstoff

Ottone
 Brass
 Laiton
 Messing

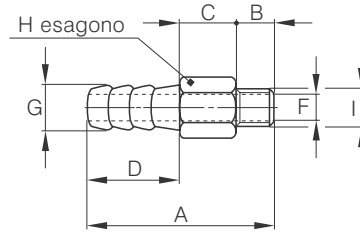

A	B	C	D	F	G	H	I
50	15	8	15	7	14	14	1/4"
80	15	38	15	7	14	14	1/4"
110	15	68	15	7	14	14	1/4"
140	15	98	15	7	14	14	1/4"
50	10	17	14	5	12	12	1/8"
75	10	37	14	5	12	12	1/8"
100	10	67	14	5	12	12	1/8"
50	10	15	24,5	7	12	12	M10

A richiesta zincati

Acciaio
Steel
Acier
Werkstoff

Ottone
 Brass
 Laiton
 Messing

Raccordi per stampi con esagono interno
Hose extension exagonal interior
Raccord mouliste avec intern exagonal
Anschlußnippel mit Innen Sechskant

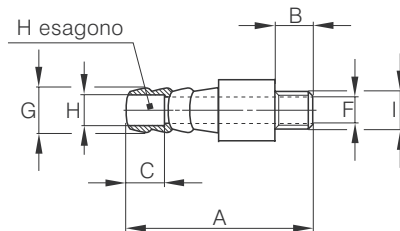

A	B	C	F	G	H	I
50	15	7	8	13	6	1/4"
80	15	7	8	13	6	1/4"
110	15	7	8	13	6	1/4"
140	15	7	8	13	6	1/4"
200	15	7	8	13	6	1/4"
50	10	7	5	10	5	1/8"
75	10	7	5	10	5	1/8"
100	10	7	5	10	5	1/8"
140	10	7	5	10	5	1/8"
200	10	7	5	10	5	1/8"

A richiesta zincati

Tappi per circuiti di raffreddamento
Plugs with O-ring seal
Bouchon avec anneau torique
Verschluss stopfen

BM
Industrie

Acciaio
Steel
Acier
Werkstoff

Ottone

Brass or viton

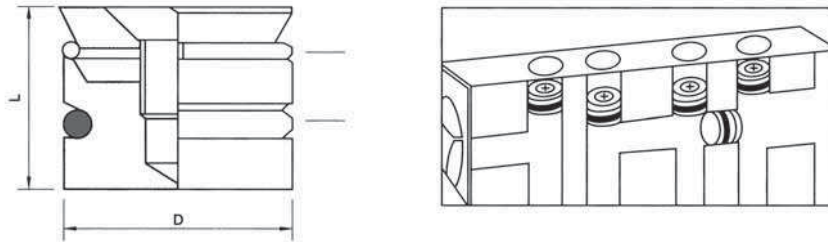

D	L	
6	10	
8	10	
10	11	
12	12	

Tipo AG/S

Applicazioni e vantaggi

Questo dispositivo è indispensabile specialmente per gli stampi a ganasce mobile, in quanto deve essere garantito che le spine di estrazione non vengano piegate o tranciate dai tasselli laterali.

Si rende quindi necessario che le spine di estrazione vengano ritirate prima della chiusura dello stampo. Questo può essere ottenuto mediante l'impiego di un dispositivo automatico di estrazione - richiamo. Il nostro dispositivo garantisce una sicurezza dovuta a collaudi effettuati nelle più svariate lavorazioni di stampaggio e unisce un risparmio ai gravosi costi di riparazione dello stampo e inutili perdite di tempo.

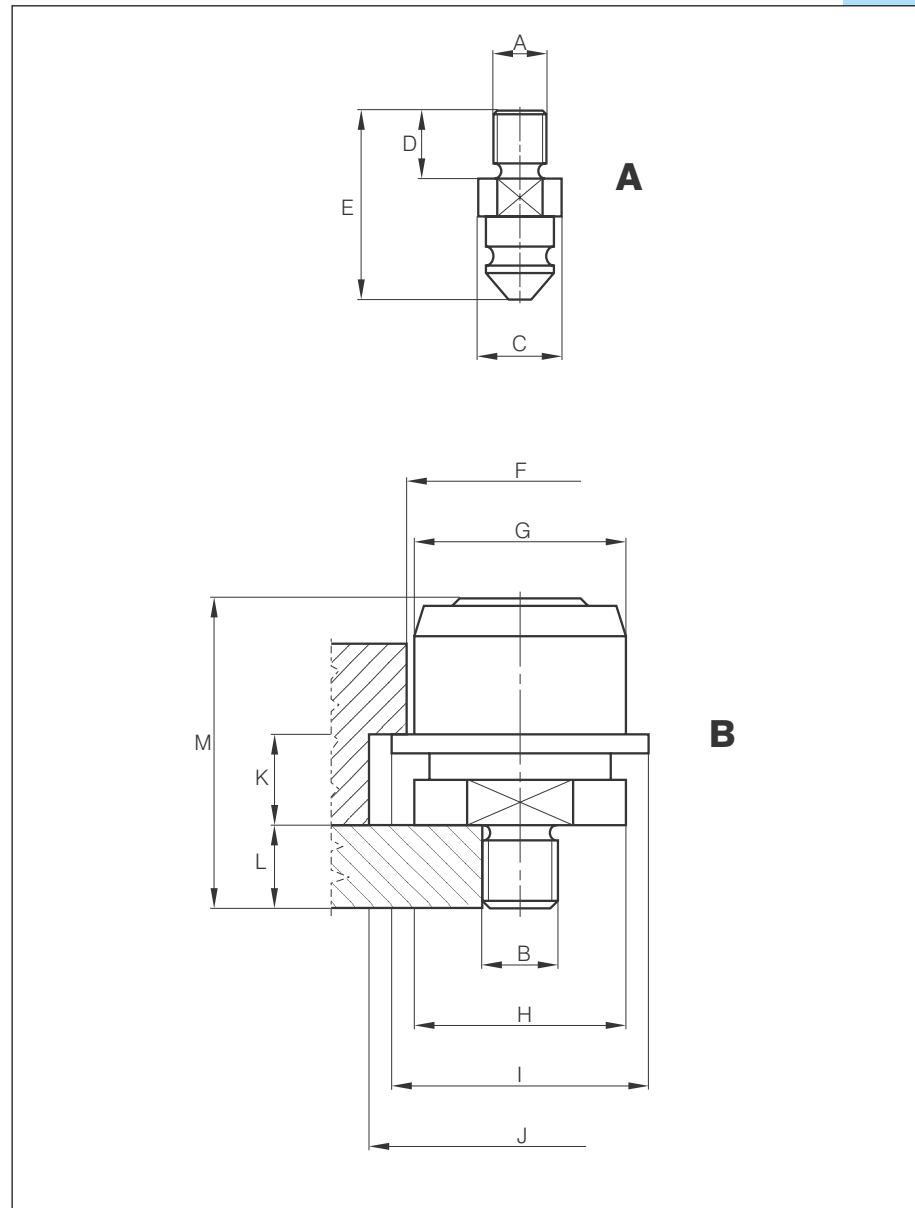

A					B									
ø A	C	D	E	Kg.	ø B	F	G	H	I	J	$K_{-0}^{+0.1}$	L	M	Kg.
M 10 x 1,5	26	20	56	2.500	M 16 x 1,5	40	38	38	48	50	$15_{-0}^{+0.1}$	14	52	2.500
M 12 x 1,75					M 16 x 1,5									
M 14 x 2					M 16 x 1,5									
M 16 x 2	35	25	68	3.500	M 16 x 1,5	58	56	52	64	70	$17_{-0}^{+0.1}$	18	68	3.500
M 18 x 2,5					M 18 x 1,5									
M 20 x 2,5					M 18 x 1,5									
M 24 x 3					M 20 x 1,5									
M 30 x 3,5					M 20 x 1,5									

Montare il corpo del dispositivo sul tavolino della piastra porta estrattori e il perno sull'estrattore della macchina

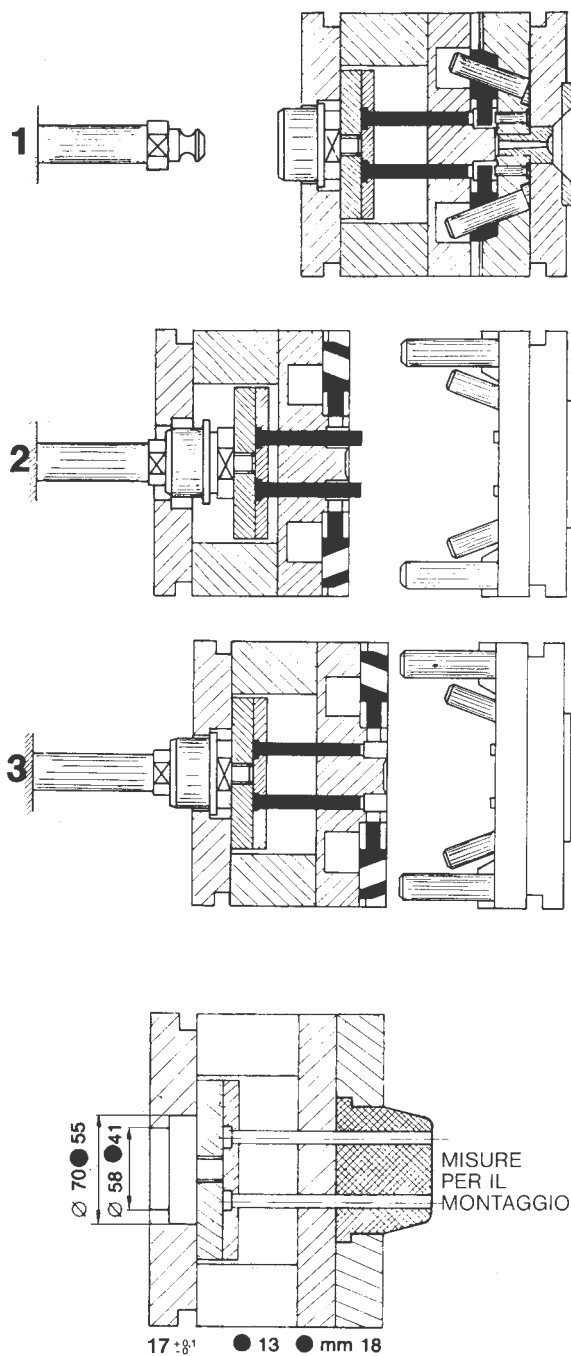

Questo dispositivo è indispensabile specialmente per gli stampi a ganascia mobile, in quanto deve essere garantito che le spine di estrazione non vengano piegate o tranciate dai tasselli laterali. Si rende quindi necessario che le spine di estrazione vengano ritirate prima della chiusura dello stampo. Questo può essere ottenuto mediante l'impiego di un dispositivo automatico di estrazione - richiamo. Il dispositivo garantisce una sicurezza dovuta a collaudi effettuati nelle più svariate lavorazioni di stampaggio e unisce un risparmio ai gravosi costi di riparazione dello stampo e inutili perdite di tempo.

FUNZIONAMENTO

- 1) Stampo chiuso. Il materiale viene iniettato.
- 2) Stampo in posizione di estrazione. I tasselli laterali sono usciti. Il perno fisso di estrazione - richiamo è agganciato nel perno mobile del dispositivo e ha eseguito l'estrazione del pezzo stampato.
- 3) Lo stampo si chiude e richiama il gruppo estrazione alla posizione di battuta. I tasselli mobili laterali possono ora rientrare senza ostacoli.

● Misure tipo mignon

Type AG/S

Used and advantages

This device is indispensable especially for moving jaw mould, as the lifting pins must neither be bent nor shorn by the lateral small blocks. Therefore it is necessary that the lifting pins should be withdrawn before the closing of the mould.

All this can be obtained with the use of an automatic lifting-return device.

Our device guarantees safety thanks to tests made in the most various pressing works and moreover adds savings of the heavy costs to repair the die and avoids useless waste of time.

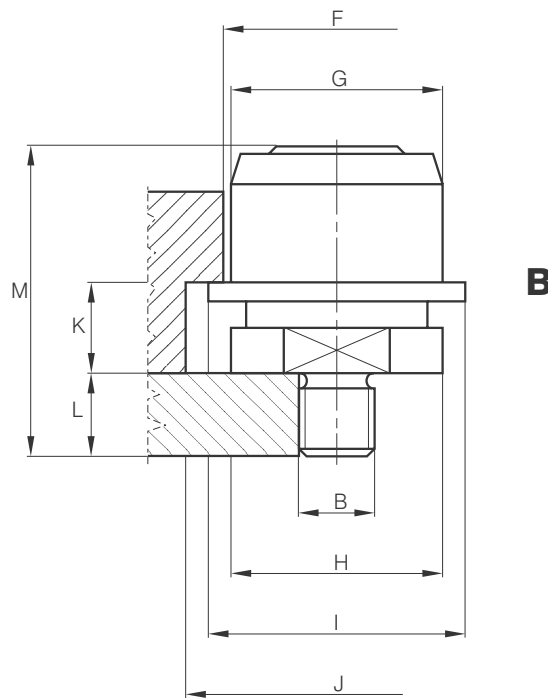
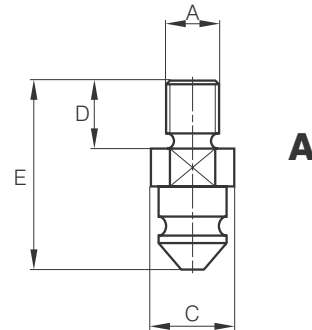

A					B									
ø A	C	D	E	Kg.	ø B	F	G	H	I	J	$K_{-0}^{+0.1}$	L	M	Kg.
M 10 x 1,5	26	20	56	2.500	M 16 x 1,5	40	38	38	48	50	$15_{-0}^{+0.1}$	14	52	2.500
M 12 x 1,75														
M 14 x 2														
M 16 x 2	35	25	68	3.500	M 16 x 1,5	58	56	52	64	70	$17_{-0}^{+0.1}$	18	68	3.500
M 18 x 2,5														
M 20 x 2,5														
M 24 x 3														
M 30 x 3,5														

Fix the body of the device on the small table of the extractor-holder plate and the pin on the machine ejector

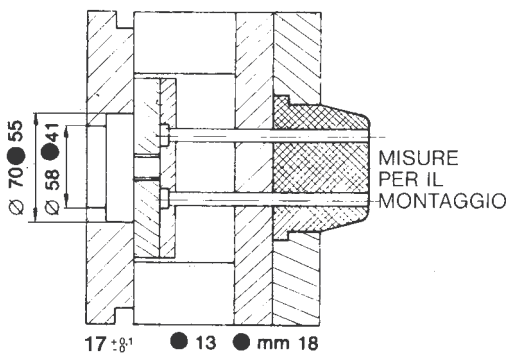
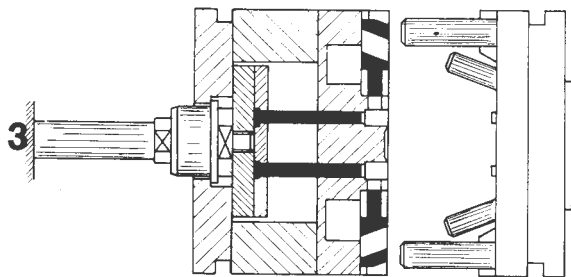
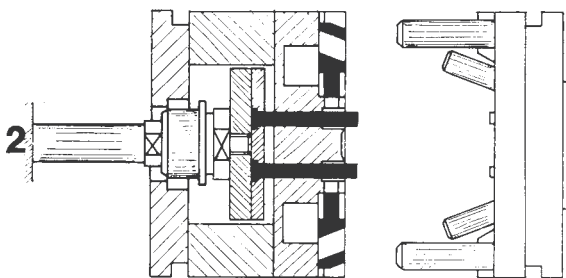
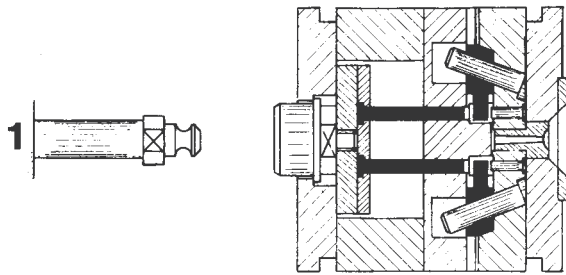

This device is indispensable especially for moving jaw moulds, as the lifting pins must neither be bent nor shorn by the lateral small blocks. Therefore it is necessary that the lifting pins should be withdrawn before the closing of the mould.

All this can be obtained with the use of an automatic lifting-return device.

Our device guarantees safety due to tests made in the most various pressing works and moreover, savings of the heavy costs to repair the mould and avoids useless waste of time.

HOW TO OPERATE

- 1) Closed mould. The material is injected.
- 2) Mould lifting position. The lateral blocks are out. The stationary pins of lifting-return are hooked at the moving pin and the device has done the lifting of the pressed piece.
- 3) The mould is closed and it draws the assembly to the ledge position. The lateral moving blocks may now re-enter without obstacles.

● Type Mignon

Type AG/S

Application et avantages

Ce dispositif est indispensable spécialement pour les moules à mâchoire mobile vu qu'elle doit garantir que les goupilles d'extraction ne soient pas pliées ou tranchées par les chevilles latérales. Il est donc nécessaire que les goupilles d'extraction soient retirées avant la fermeture du moule. On peut l'obtenir grâce à l'emploi d'un dispositif automatique d'extraction-rappel. Notre dispositif garantit une sécurité due à des essais effectués durant les usinages les plus variés de moulage et, le tout mis ensemble, produit une économie sur les coûts élevés de réparation du moule et évite aussi une perte inutile de temps.

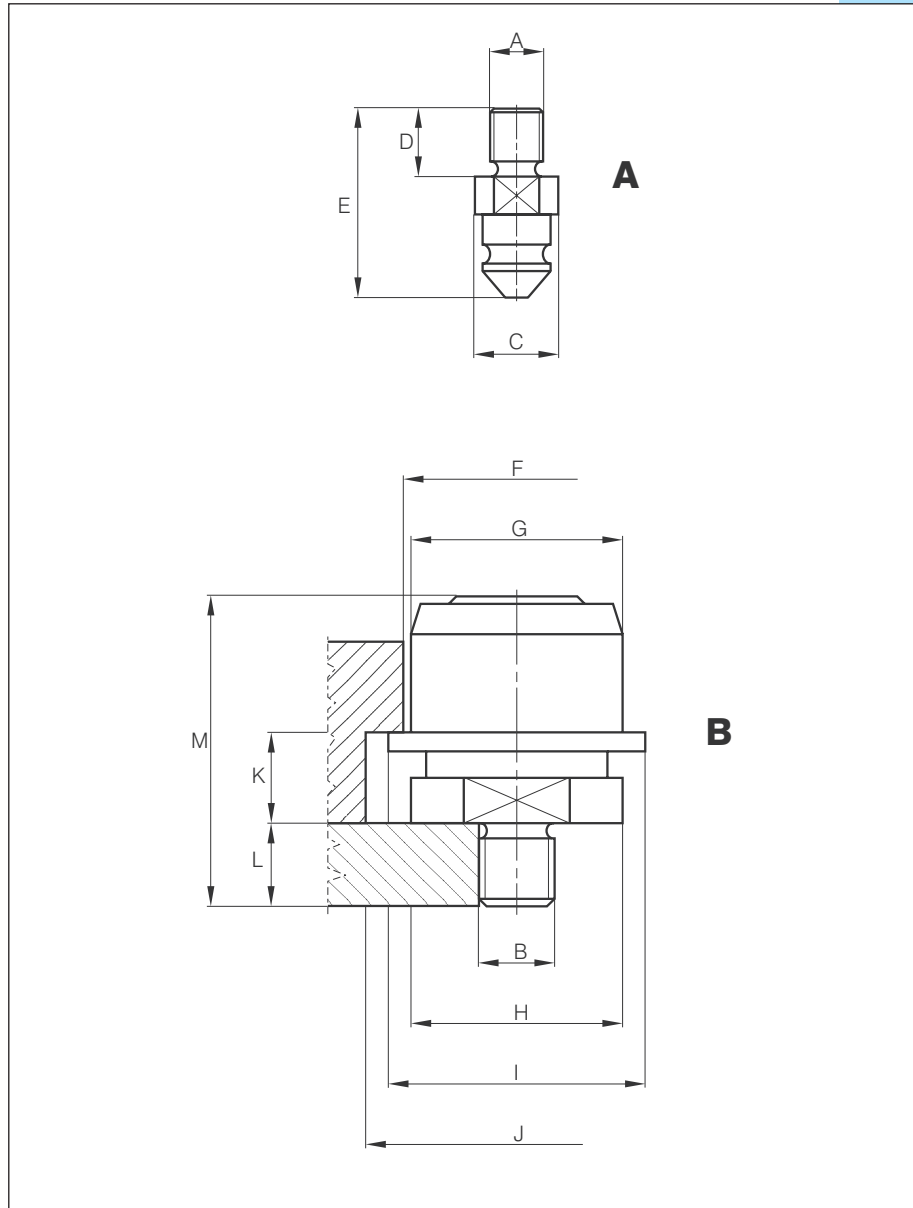

A					B									
ø A	C	D	E	Kg.	ø B	F	G	H	I	J	$K_{-0}^{+0.1}$	L	M	Kg.
M 10 x 1,5	26	20	56	2.500	M 16 x 1,5	40	38	38	48	50	$15_{-0}^{+0.1}$	14	52	2.500
M 12 x 1,75														
M 14 x 2														
M 16 x 2	35	25	68	3.500	M 16 x 1,5	58	56	52	64	70	$17_{-0}^{+0.1}$	18	68	3.500
M 18 x 2,5														
M 20 x 2,5														
M 24 x 3														
M 30 x 3,5														

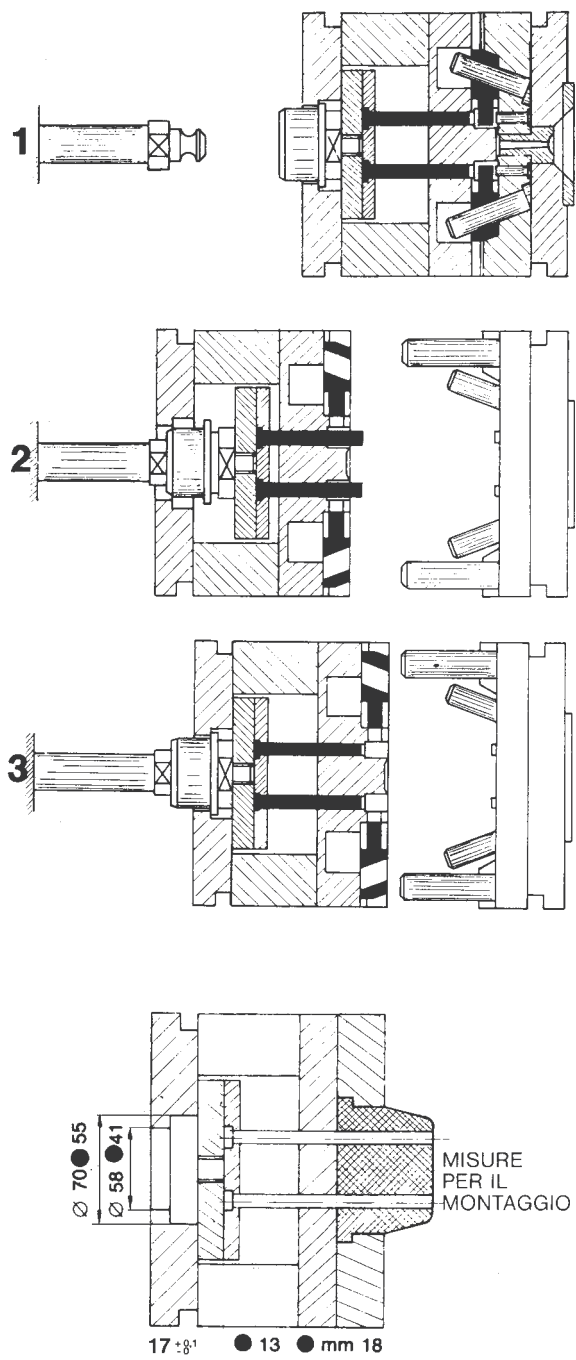

Ce dispositif est indispensable spécialement pour les moules à mâchoire mobile vu qu'elle doit garantir que les goupilles d'extraction ne soient pas pliées ou tranchées par les chevilles latérales. Il est donc nécessaire que les goupilles d'extraction soient retirées avant la fermeture du moule. On peut l'obtenir grâce à l'emploi d'un dispositif automatique d'extraction-rappel. Notre dispositif garantit une sécurité due à des essais effectués durant les usinages les plus variés de moulage et, le tout mis ensemble, produit une économie sur les coûts élevés de réparation du moule et évite aussi une perte inutile de temps.

FUNZIONAMENTO

- 1) Moule fermé. Le matériel est injecté.
- 2) Moule en position d'extraction. Les chevilles latérales sont sorties. Le pivot fixe d'extraction-renvoi est accroché dans le pivot mobile du dispositif et a exécuté l'extraction de l'objet moulé.
- 3) le moule se ferme et rappelle le groupe d'extraction jusqu'à la position de butée. Les chevilles mobiles latérales peuvent alors rentrer sans obstacle.

● Mignon type

Type AG/S

Anwendung und Vorteile

Insbesondere bei Backenformen muß es gewährleistet sein, daß die Auswerferstifte in ihre Ausgangsposition zurückgeführt werden, da die schliessenden Backen bzw. Seitenschieber die Auswerferstifte andernfalls abscheren oder verbgen würden.

Es muß demzufolge dafür gesorgt werden, daß die Auswerferstifte bereits zurückgezogen sind, bevor die Schließbewegung der Backen beginnt.

Diese Forderung kann beim Einsatz unserer automatischen Auswerfer Rückzug Einrichtung mit Sicherheit erfüllt werden. Durch den Einsatz dieser Rückzugeinrichtung ersparen Sie hohe Reparatur - Kosten und Ausfallzeiten.

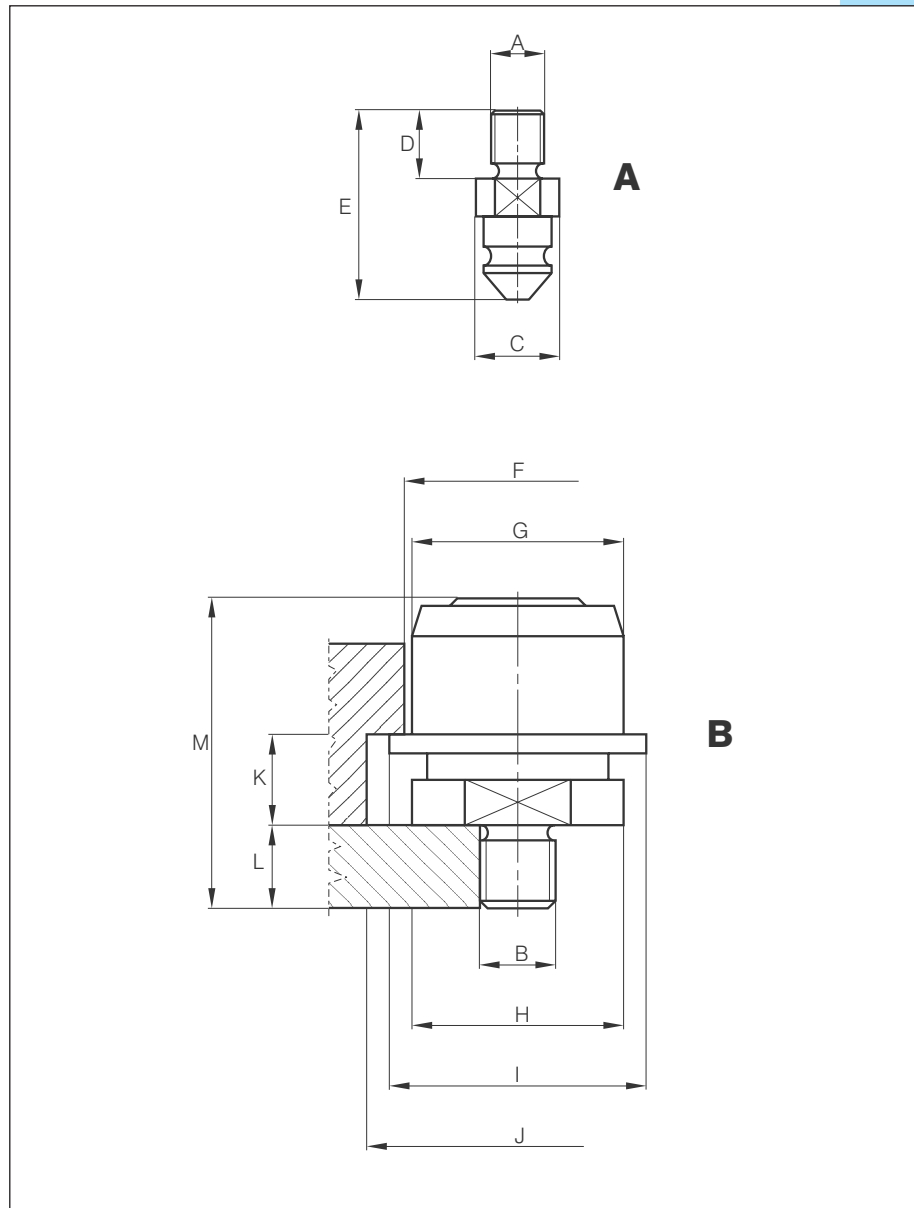

A					B									
ø A	C	D	E	Kg.	ø B	F	G	H	I	J	$K_{-0}^{+0.1}$	L	M	Kg.
M 10 x 1,5	26	20	56	2.500	M 16 x 1,5	40	38	38	48	50	$15_{-0}^{+0.1}$	14	52	2.500
M 12 x 1,75					M 16 x 1,5									
M 14 x 2					M 16 x 1,5									
M 16 x 2	35	25	68	3.500	M 16 x 1,5	58	56	52	64	70	$17_{-0}^{+0.1}$	18	68	3.500
M 18 x 2,5					M 18 x 1,5									
M 20 x 2,5					M 18 x 1,5									
M 24 x 3					M 20 x 1,5									
M 30 x 3,5					M 20 x 1,5									

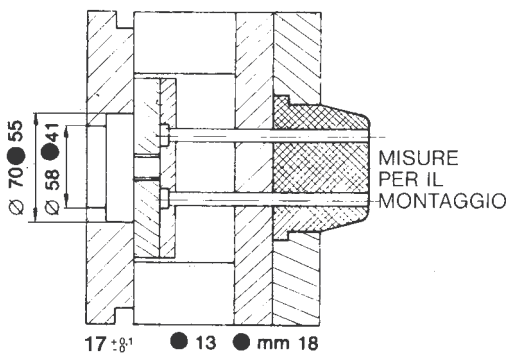
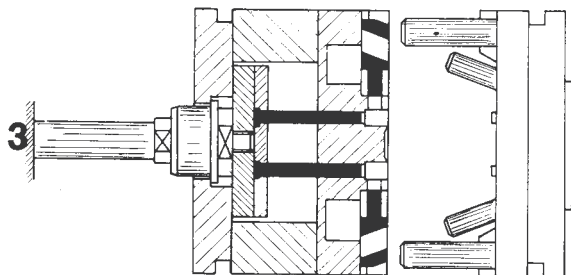
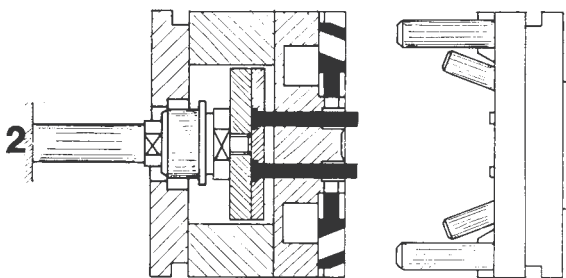
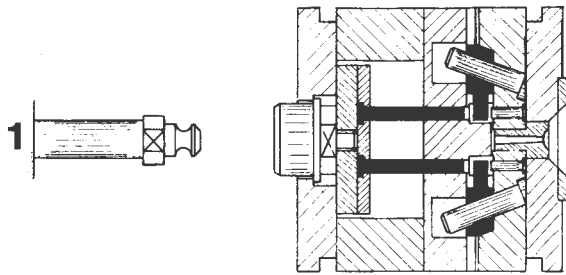

Insbesondere bei Backenformen muß gewährleistet sein, daß die Auswerferstifte in ihre Ausgangs-Position zurückgeführt werden, da die schließenden Backen bzw.

Seitenschieber die Auswerferstifte andernfalls abscheren oder verbogen würden.

Es muß demzufolge dafür gesorgt werden, daß die Auswerferstifte bereits zurückgezogen sind, bevor die Schließbewegung der Backen beginnt.

Diese Forderung kann bei Einsatz unserer Automatischen Auswerfer Rückzug Einrichtung mit Sicherheit erfüllt werden. Durch den Einsatz dieser Rückzugeinrichtung ersparen Sie hohe Reparatur - Kosten und Ausfallzeiten.

FUNKTIONSW EISE

1) Formwerkzeug geschlossen. Der Einspritzvorgang beginnt.

2) Formwerkzeug in Auswerferstellung. Die Seitenschleber sind ausgefahren, der Rückzugbolzen ist mittels Kugelein mit dem Auswerferplatte wird zum Auswerferbolzen verastet.

3) Formwerkzeug schließt sich. Die Auswerferplatte wird zum Anschlag zurückgezogen. Rückzugbolzen und Auswerferbolzen rasten aus. Auf dem Restweg der Schliessbewegung werden die Backen ohne Hindernis zugefahren.

● Mignon Typ

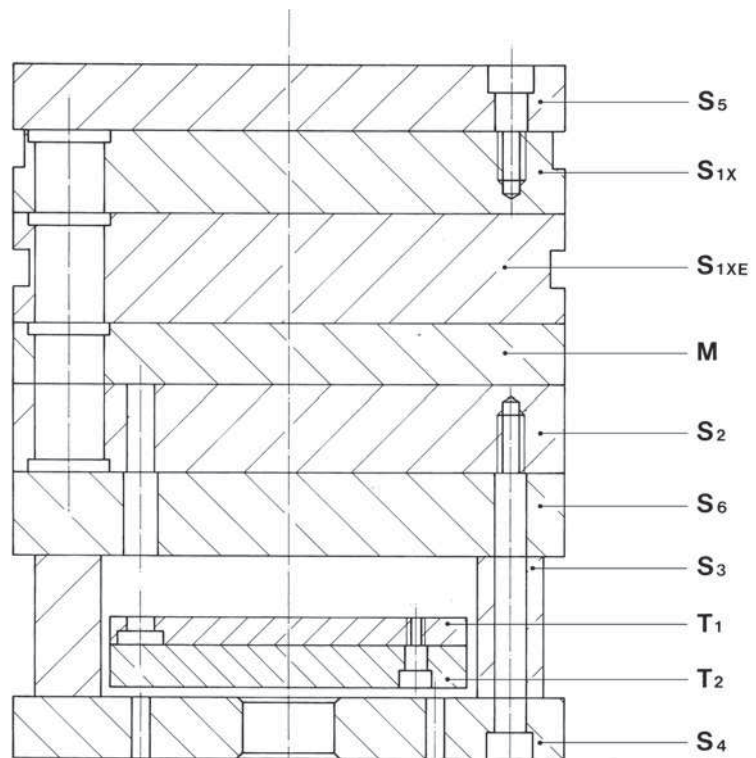
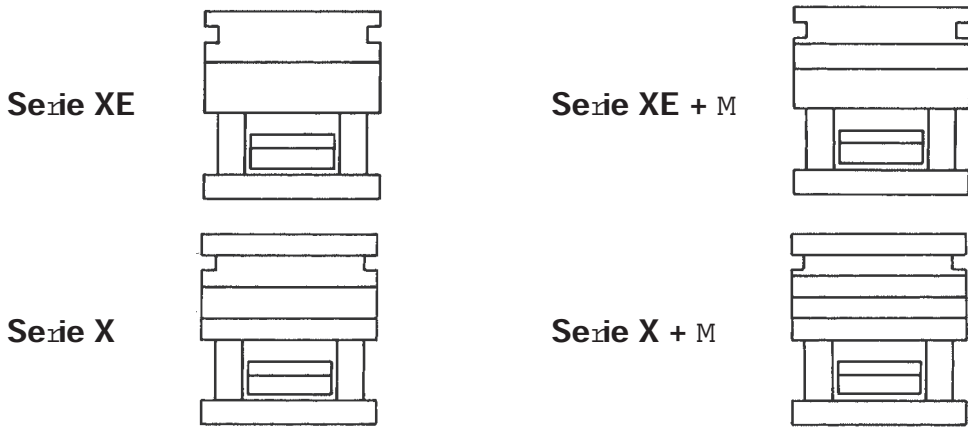

S1XE iastrA ortAforma su eriore er ti o E
 Cam ate for t e E

S1X iastrA ortAforma su eriore er ti o
 Cam ate for t e

S2 iastrA ortAforma inferiore
 Ca it ate

S3 DistanZia i
 DistanCe - Bushes

S4 iastrA di fissaggio inferiore
 Cam ate

S5 iastrA di fissaggio su eriore
 Cam ate

S6 iastrA intermedia er ti o x
 Bac ing ate

M iastrA ortAforma mo ie
 Ca it ate

T1 iastrA ta o ino estrazione su eriore
 E ector ate

T2 iastrA ta o ino estrazione inferiore
 E ector ate ase

Colonne di guida
Guide pins
Colonnes
Präzision Führungssäulen

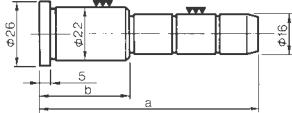

b	a									
50	60	70	80	90	100	120	140	160	180	200
22										
26										
36										
46										
56										

Bussole di guida
Bushes
Bagues
Führungsbuchse

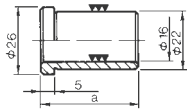

a						
22	26	36	46	56	66	76

Bussole di guida
Bushes
Bagues
Führungsbuchse

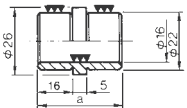

a	
32	40

Espulsori
Ejctor
Ejecteurs
Auswerferstifte

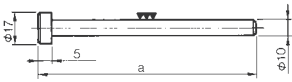

a									
100	125	150	175	200	250	300	350	400	600

Viti
Screws
Vises

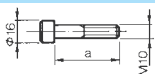

a									
16	18	20	25	30	35	40	45	50	55
60	70	80	90	100	110	120	130	140	150
160	180	200	220	240	260	280	300		

Serie XE 156 x 156

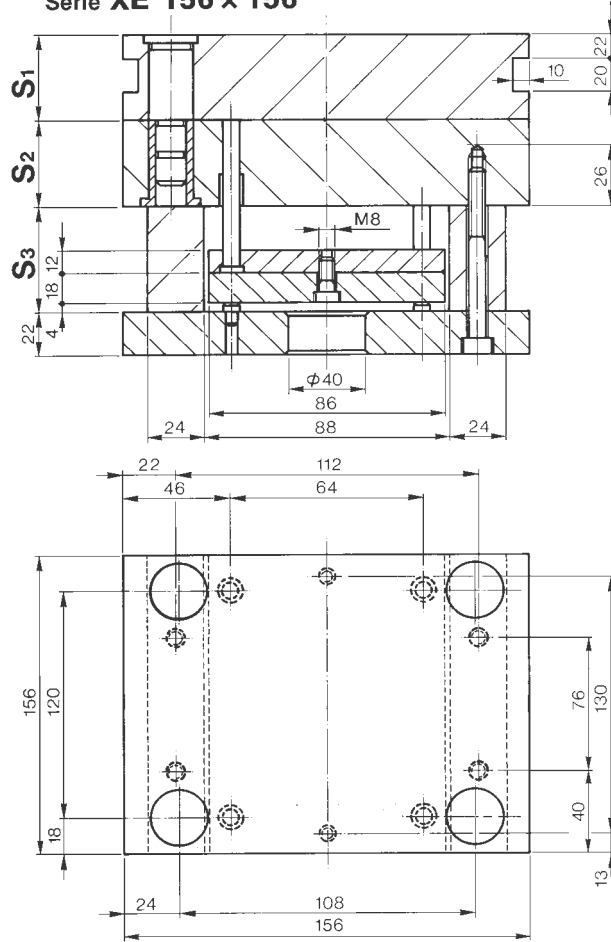

Serie XE + M 156 x 156

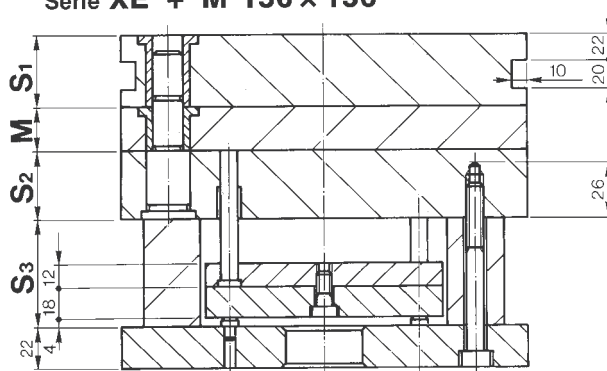

S ₁	S ₂	S ₃	M
36	36	57	26
46	46	77	36
56	56		46
66	66		56

Colonne di guida
Guide pins
Colonnes
Präzision Führungssäulen

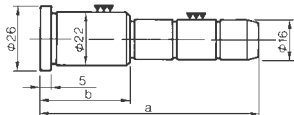

b	a										
	50	60	70	80	90	100	120	140	160	180	200
22											
26											
36											
46											
56											

Bussole di guida
Bushes
Bagues
Führungsbuchse

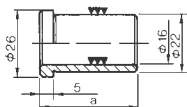

a						
22	26	36	46	56	66	76

Bussole di guida
Bushes
Bagues
Führungsbuchse

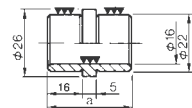

a	
32	40

Espulsori
Ejctor
Ejecteurs
Auswerferstifte

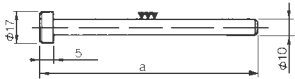

a										
100	125	150	175	200	250	300	350	400	600	

Viti
Screws
Vises

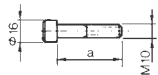

a										
16	18	20	25	30	35	40	45	50	55	
60	70	80	90	100	110	120	130	140	150	
160	180	200	220	240	260	280	300			

Serie XE 156 x 196

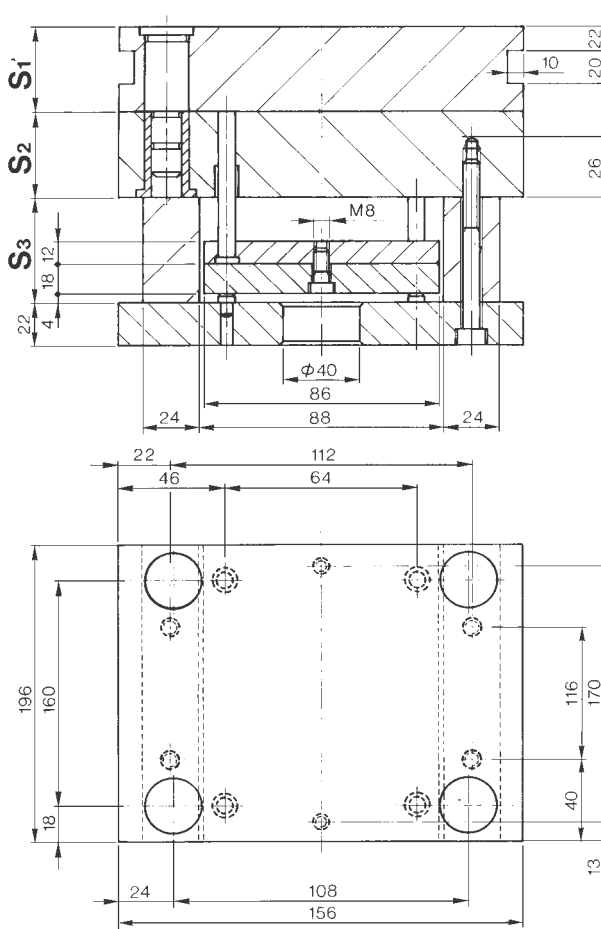

Serie XE + M 156 x 196

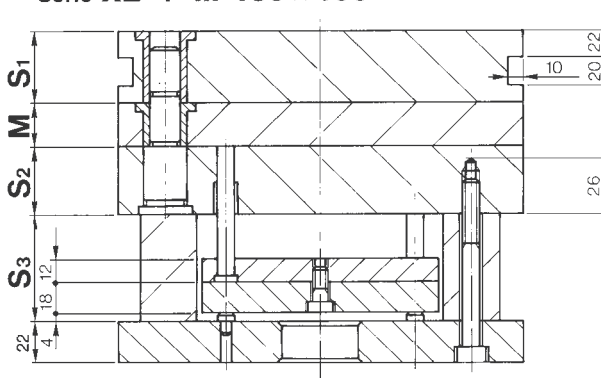

S ₁	S ₂	S ₃	M
36	36	57	26
46	46	77	36
56	56		46
66	66		56

Colonne di guida
Guide pins
Colonnes
Präzision Führungssäulen

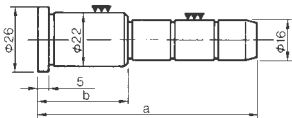

b	a																
	50	60	70	80	90	100	120	140	160	180	200						
22																	
26																	
36																	
46																	
56																	

Bussole di guida
Bushes
Bagues
Führungsbuchse

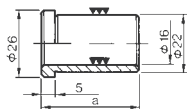

a						
22	26	36	46	56	66	76

Bussole di guida
Bushes
Bagues
Führungsbuchse

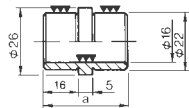

a	
32	40

Espulsori
Ejctor
Ejecteurs
Auswerferstifte

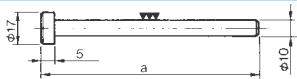

a									
100	125	150	175	200	250	300	350	400	600

Viti
Screws
Vises

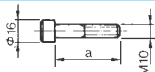

a										
16	18	20	25	30	35	40	45	50	55	
60	70	80	90	100	110	120	130	140	150	
160	180	200	220	240	260	280	300			

Serie XE 156 x 246

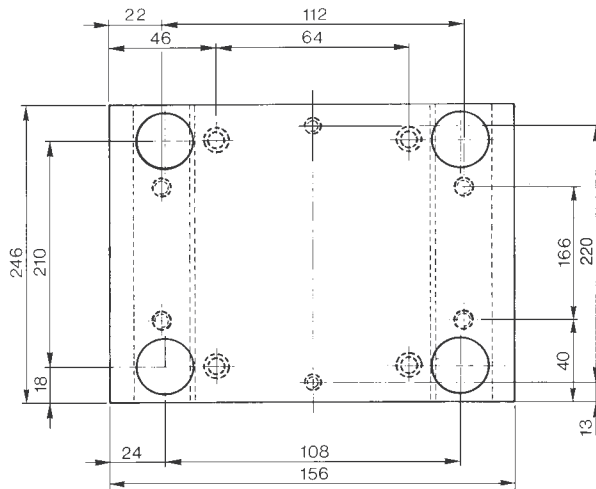
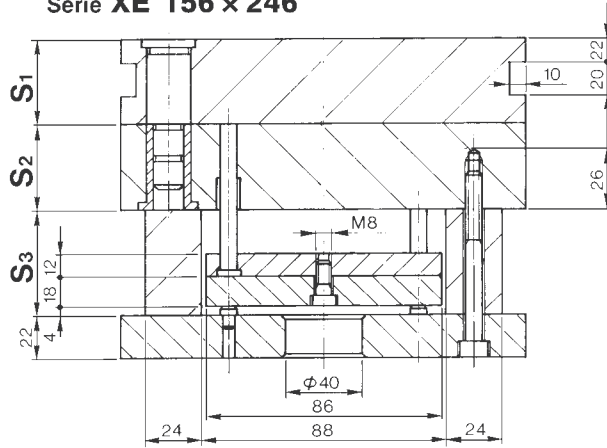

Serie XE + M 156 x 246

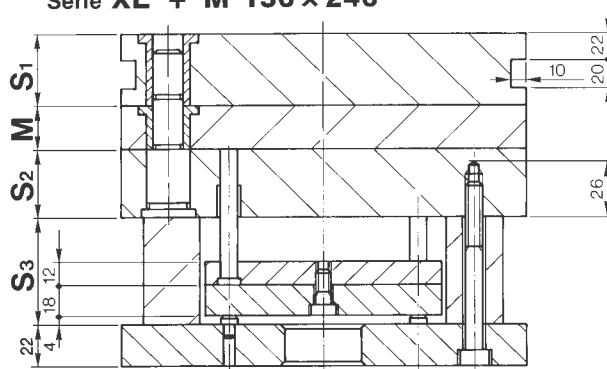

S ₁	S ₂	S ₃	M
36	36	57	26
46	46	77	36
56	56		46
66	66		56

Colonne di guida
Guide pins
Colonnes
Präzision Führungssäulen

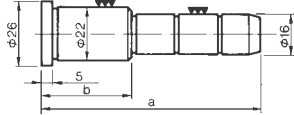

b	a																	
	50	60	70	80	90	100	120	140	160	180	200							
22																		
26																		
36																		
46																		
56																		

Bussole di guida
Bushes
Bagues
Führungsbuchse

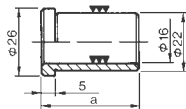

a							
22	26	36	46	56	66	76	

Bussole di guida
Bushes
Bagues
Führungsbuchse

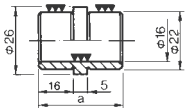

a	
32	40

Espulsori
Ejector
Éjecteurs
Auswerferstifte

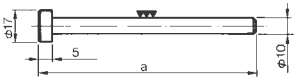

a									
100	125	150	175	200	250	300	350	400	600

Viti
Screws
Vises

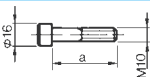

a												
16	18	20	25	30	35	40	45	50	55			
60	70	80	90	100	110	120	130	140	150			
160	180	200	220	240	260	280	300					

Serie XE 196 x 196

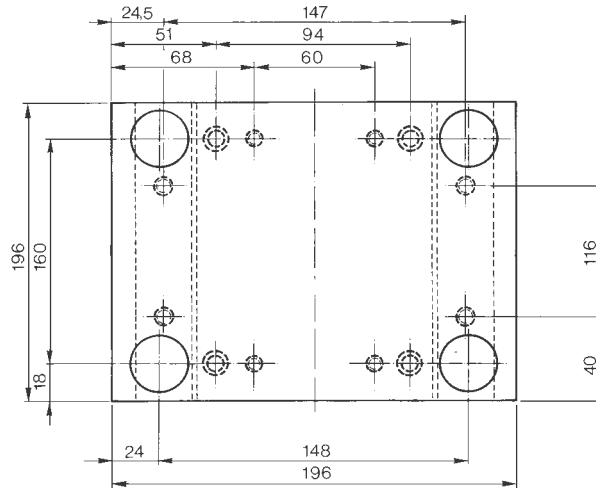
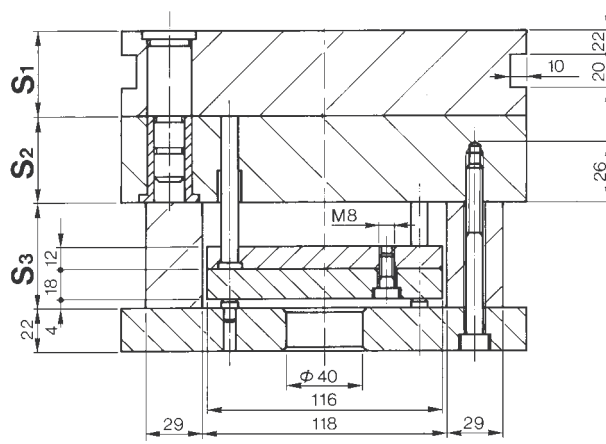

Serie XE + M 196 x 196

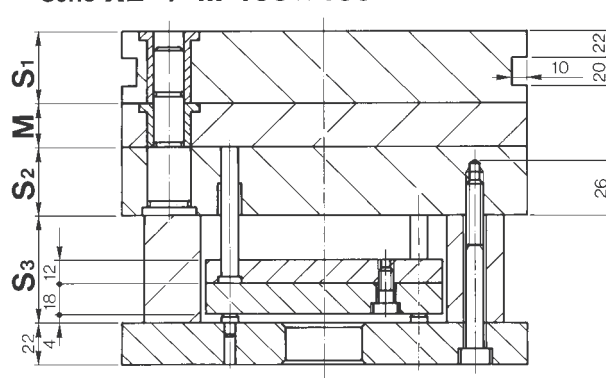

S ₁	S ₂	S ₃	M
46	46	57	26
56	56	77	36
66	66	97	46
76	76		56
96	96		66

Colonne di guida
Guide pins
Colonnes
Präzision Führungssäulen

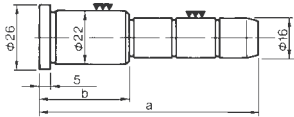

b	a										
	50	60	70	80	90	100	120	140	160	180	200
22											
26											
36											
46											
56											

Bussole di guida
Bushes
Bagues
Führungsbuchse

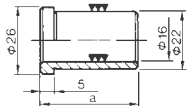

a						
22	26	36	46	56	66	76

Bussole di guida
Bushes
Bagues
Führungsbuchse

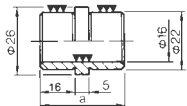

a	
32	40

Espulsori
Ejctor
Ejecteurs
Auswerferstifte

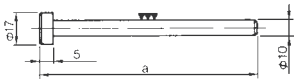

a									
100	125	150	175	200	250	300	350	400	600

Viti
Screws
Vises

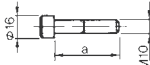

a										
16	18	20	25	30	35	40	45	50	55	
60	70	80	90	100	110	120	130	140	150	
160	180	200	220	240	260	280	300			

Serie XE 196 x 246

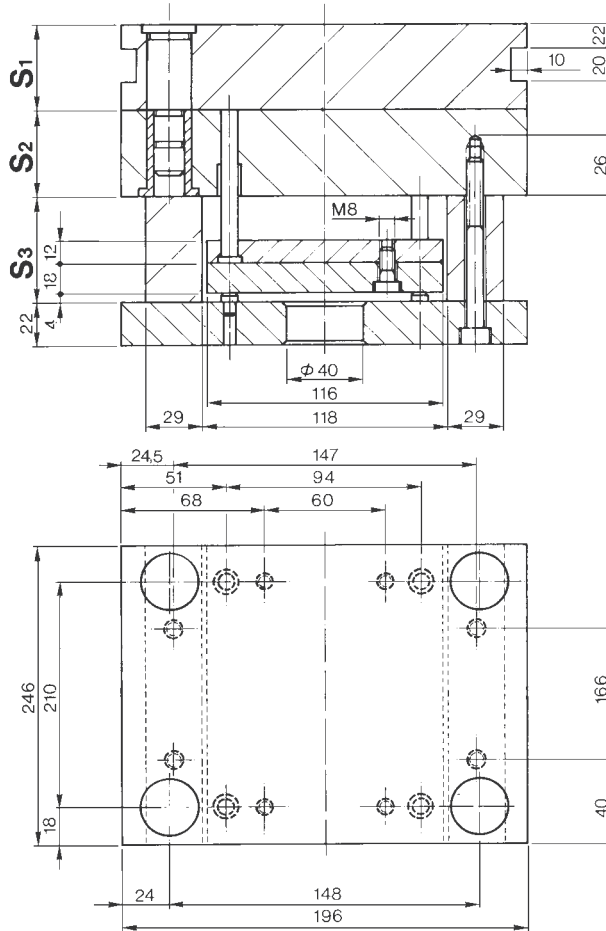

Serie XE + M 196 x 246

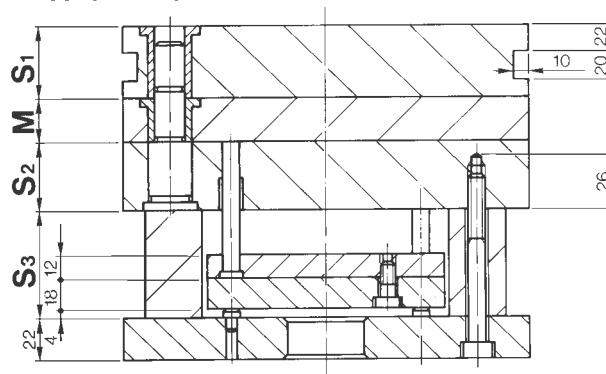

S ₁	S ₂	S ₃	M
46	46	57	26
56	56	77	36
66	66	97	46
76	76		56
96	96		66

Colonne di guida
Guide pins
Colonnes
Präzision Führungssäulen

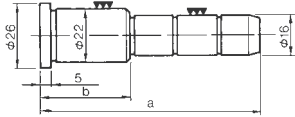

b	a																	
	50	60	70	80	90	100	120	140	160	180	200							
22																		
26																		
36																		
46																		
56																		

Bussole di guida
Bushes
Bagues
Führungsbuchse

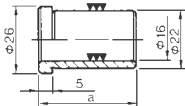

a						
22	26	36	46	56	66	76

Bussole di guida
Bushes
Bagues
Führungsbuchse

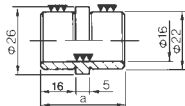

a	
32	40

Espulsori
Ejctor
Éjecteurs
Auswerferstifte

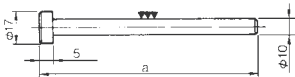

a									
100	125	150	175	200	250	300	350	400	600

Viti
Screws
Vises

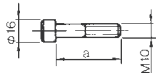

a												
16	18	20	25	30	35	40	45	50	55			
60	70	80	90	100	110	120	130	140	150			
160	180	200	220	240	260	280	300					

Serie XE 196 x 296

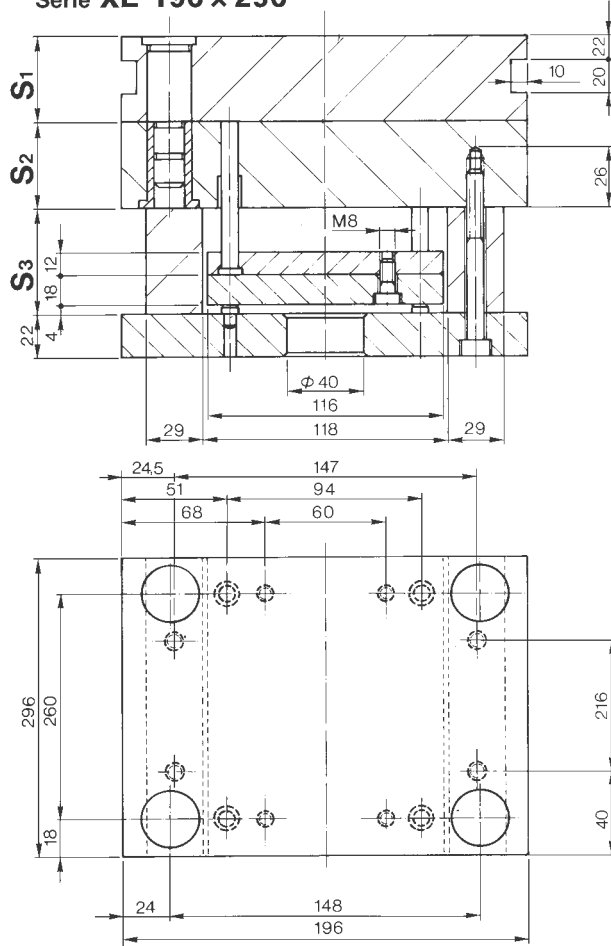

Serie XE + M 196 x 296

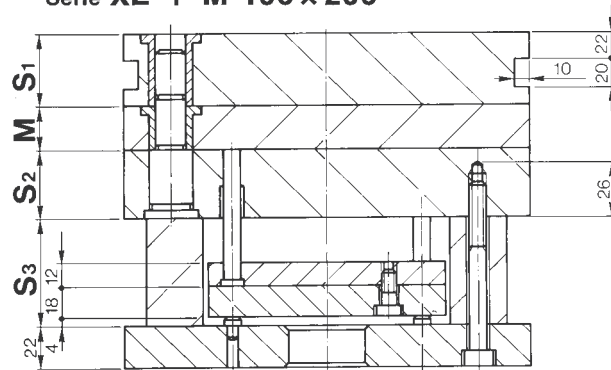

S ₁	S ₂	S ₃	M
46	46	57	26
56	56	77	36
66	66	97	46
76	76		56
96	96		66

Colonne di guida
Guide pins
Colonnes
Präzision Führungssäulen

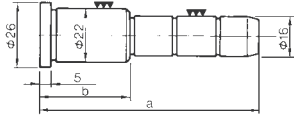

b	a										
	50	60	70	80	90	100	120	140	160	180	200
22											
26											
36											
46											
56											

Bussole di guida
Bushes
Bagues
Führungsbuchse

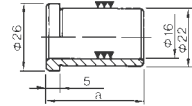

a						
22	26	36	46	56	66	76

Bussole di guida
Bushes
Bagues
Führungsbuchse

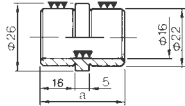

a	
32	40

Espulsori
Ejctor
Ejecteurs
Auswerferstifte

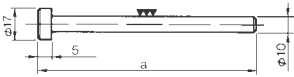

a									
100	125	150	175	200	250	300	350	400	600

Viti
Screws
Vises

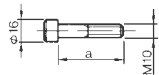

a										
16	18	20	25	30	35	40	45	50	55	
60	70	80	90	100	110	120	130	140	150	
160	180	200	220	240	260	280	300			

Serie XE 196 x 346

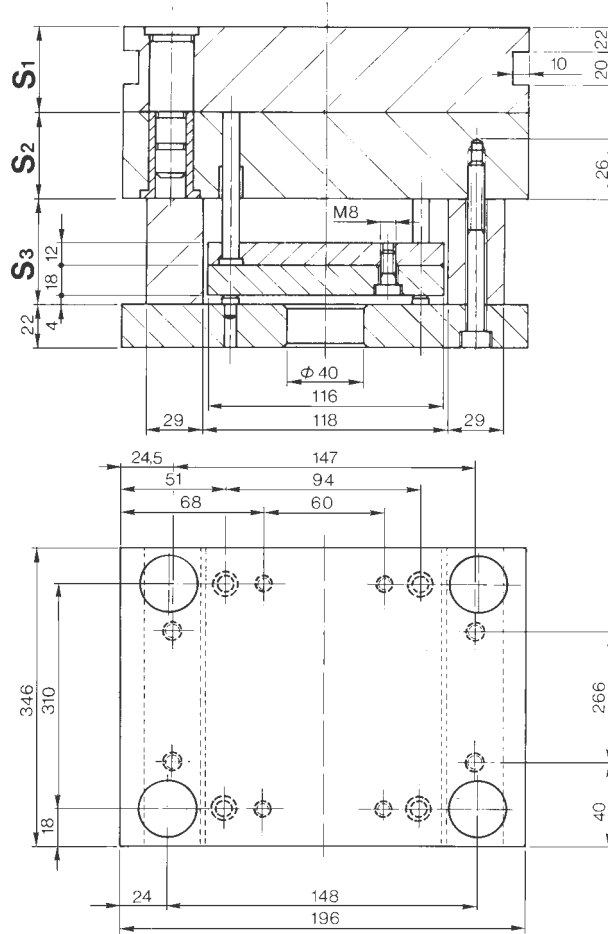

Serie XE + M 196 x 346

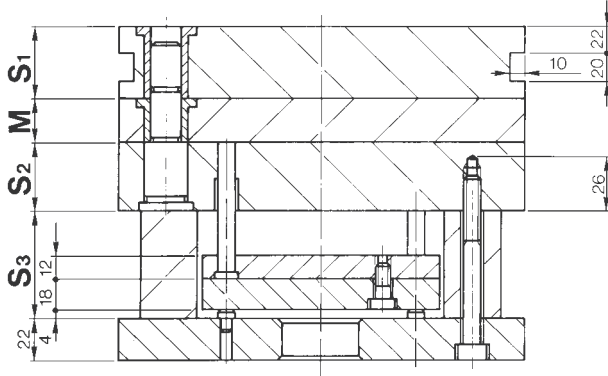

S ₁	S ₂	S ₃	M
46	46	57	26
56	56	77	36
66	66	97	46
76	76		56
96	96		66

Colonne di guida
Guide pins
Colonnes
Präzision Führungssäulen

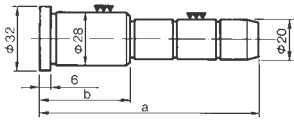

b	a										
	50	60	70	80	90	100	120	140	160	180	200
26											
36											
46											
56											
66											
76											

Bussole di guida
Bushes
Bagues
Führungsbuchse

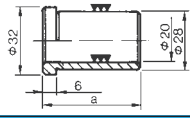

a
22
26
36
46
56
66
76
96

Bussole di guida
Bushes
Bagues
Führungsbuchse

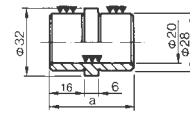

a
32
40

Espulsori
Ejector
Ejecteurs
Auswerferstifte

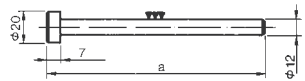

a
100
125
150
175
200
250
300
350
400
600

Viti
Screws
Vises

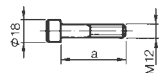

a										
16	18	20	25	30	35	40	45	50	55	
60	70	80	90	100	110	120	130	140	150	
160	180	200	220	240	260	280	300			

Serie XE 246 x 246

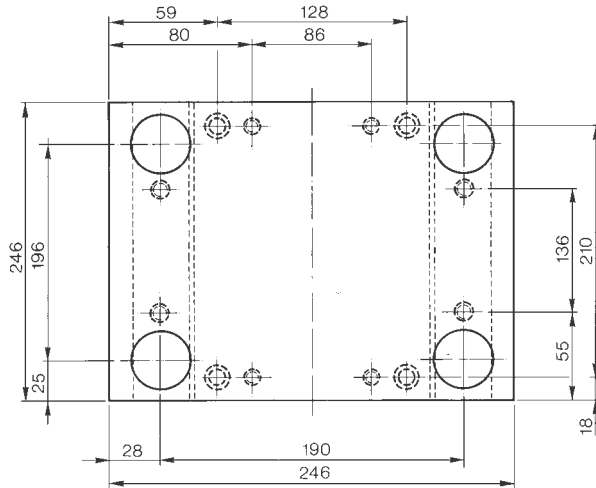
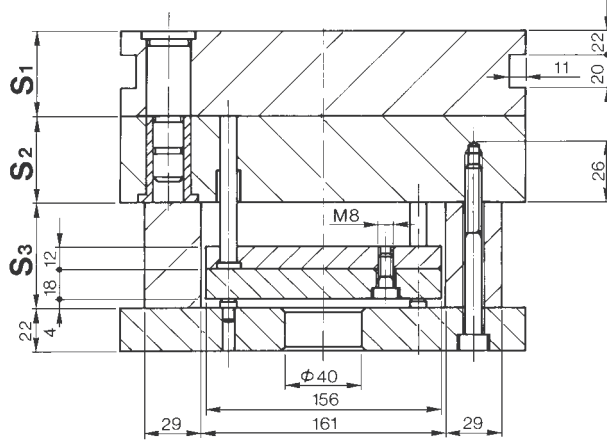

Serie XE + M 246 x 246

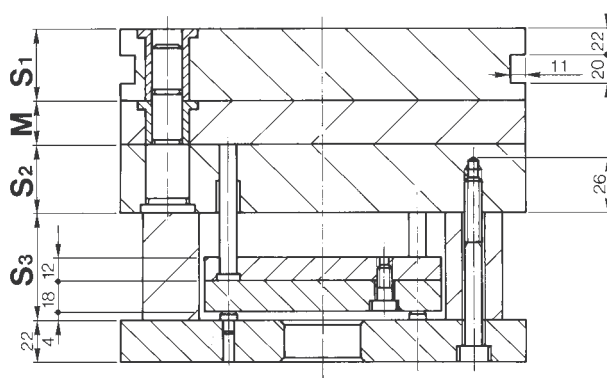

S ₁	S ₂	S ₃	M
46	46	57	26
56	56	77	36
66	66	97	46
76	76		56
96	96		66

Colonne di guida
Guide pins
Colonnes
Präzision Führungssäulen

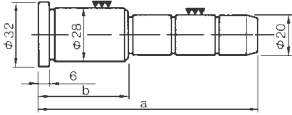

b	a										
	50	60	70	80	90	100	120	140	160	180	200
26											
36											
46											
56											
66											
76											

Bussole di guida
Bushes
Bagues
Führungsbuchse

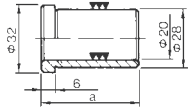

a							
22	26	36	46	56	66	76	96

Bussole di guida
Bushes
Bagues
Führungsbuchse

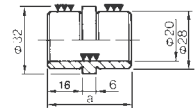

a	
32	40

Espulsori
Ejector
Ejecteurs
Auswerferstifte

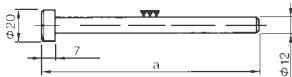

a									
100	125	150	175	200	250	300	350	400	600

Viti
Screws
Vises

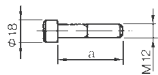

a									
16	18	20	25	30	35	40	45	50	55
60	70	80	90	100	110	120	130	140	150
160	180	200	220	240	260	280	300		

Serie XE 246 x 296

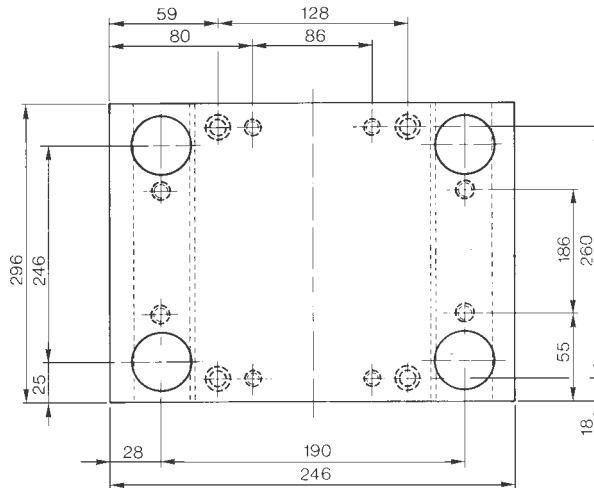
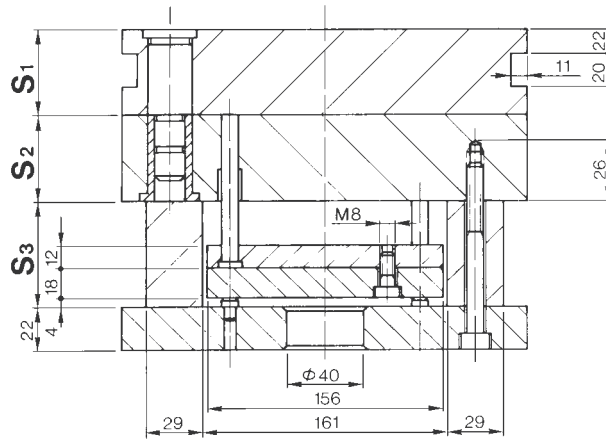

Serie XE + M 246 x 296

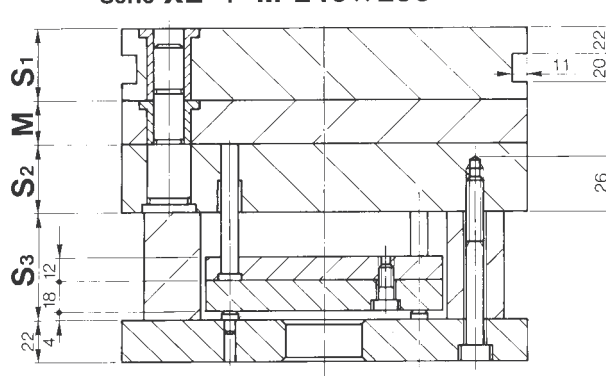

S ₁	S ₂	S ₃	M
46	46	57	26
56	56	77	36
66	66	97	46
76	76		56
96	96		66

Colonne di guida
Guide pins
Colonnes
Präzision Führungssäulen

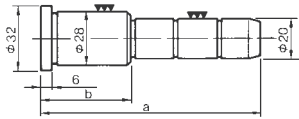

b	a										
	50	60	70	80	90	100	120	140	160	180	200
26											
36											
46											
56											
66											
76											

Bussole di guida
Bushes
Bagues
Führungsbuchse

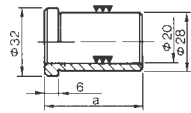

a
22
26
36
46
56
66
76
96

Bussole di guida
Bushes
Bagues
Führungsbuchse

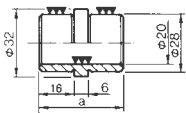

a
32
40

Espulsori
Ejector
Ejecteurs
Auswerferstifte

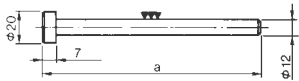

a
100
125
150
175
200
250
300
350
400
600

Viti
Screws
Vises

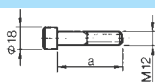

a										
16	18	20	25	30	35	40	45	50	55	
60	70	80	90	100	110	120	130	140	150	
160	180	200	220	240	260	280	300			

Serie XE 246 x 346

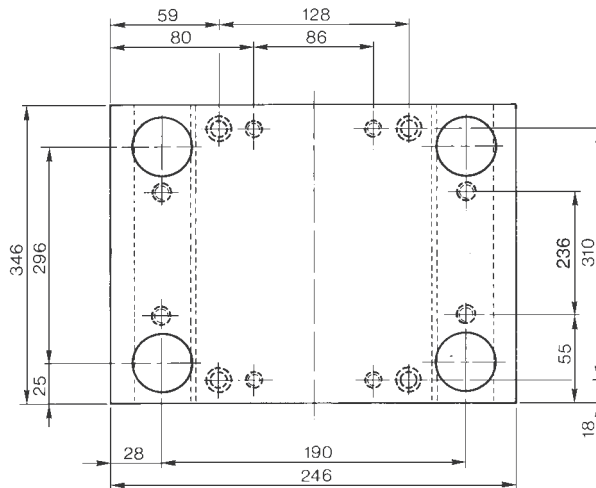
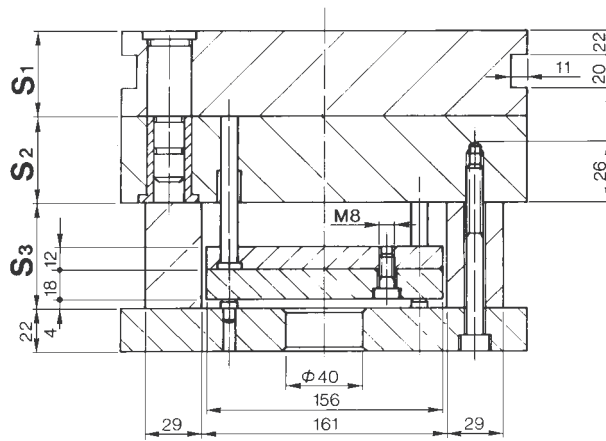

Serie XE + M 246 x 346

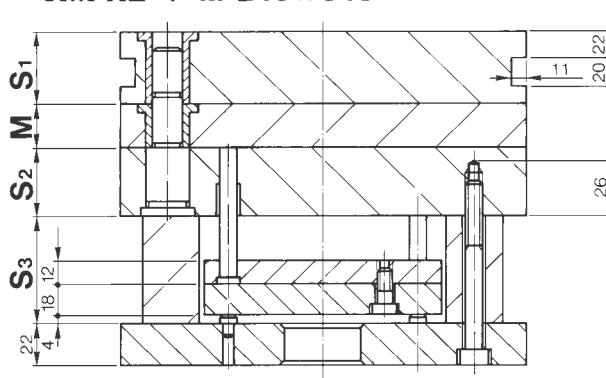

S ₁	S ₂	S ₃	M
46	46	57	26
56	56	77	36
66	66	97	46
76	76		56
96	96		66

Colonne di guida
Guide pins
Colonnes
Präzision Führungssäulen

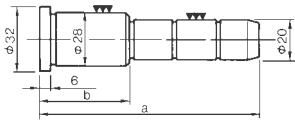

b	a										
	50	60	70	80	90	100	120	140	160	180	200
26											
36											
46											
56											
66											
76											

Bussole di guida
Bushes
Bagues
Führungsbuchse

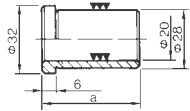

a
22
26
36
46
56
66
76
96

Bussole di guida
Bushes
Bagues
Führungsbuchse

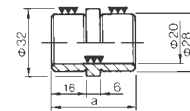

a
32
40

Espulsori
Ejector
Ejecteurs
Auswerferstifte

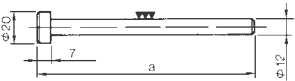

a
100
125
150
175
200
250
300
350
400
600

Viti
Screws
Vises

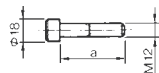

a										
16	18	20	25	30	35	40	45	50	55	
60	70	80	90	100	110	120	130	140	150	
160	180	200	220	240	260	280	300			

Serie XE 246 x 396

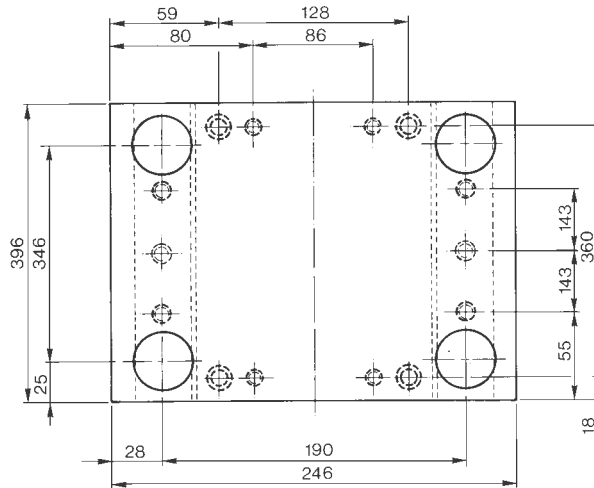
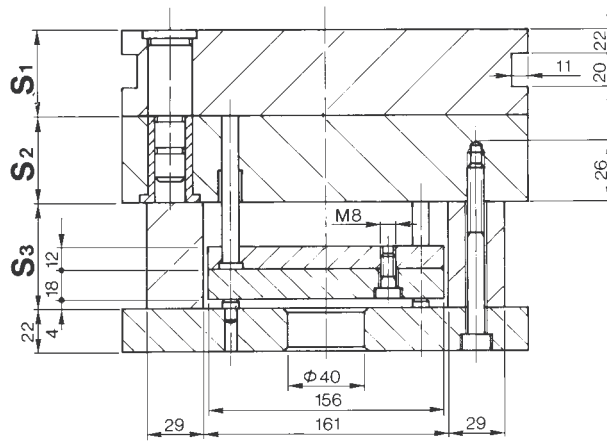

Serie XE + M 246 x 396

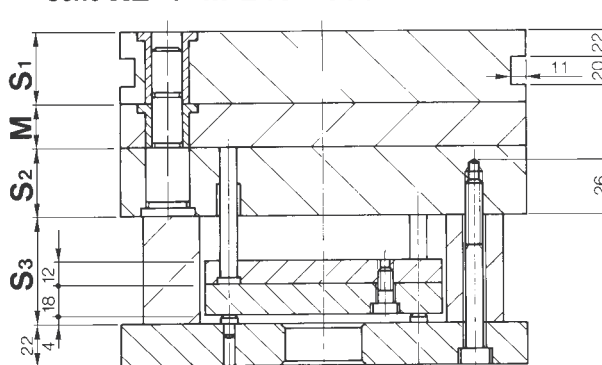

S_1	S_2	S_3	M
46	46	57	26
56	56	77	36
66	66	97	46
76	76		56
96	96		66

Colonne di guida
Guide pins
Colonnes
Präzision Führungssäulen

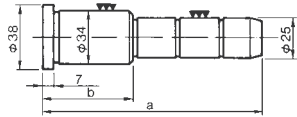

b	a												
26	80	90	100	120	140	160	180	200	220	240	260	280	
36													
46													
56													
66													
76													
86													
96													

Bussole di guida
Bushes
Bagues
Führungsbuchse

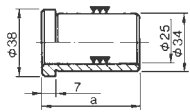

a							
26	36	46	56	66	76	86	96

Bussole di guida
Bushes
Bagues
Führungsbuchse

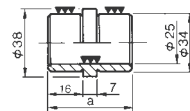

a	
32	40

Espulsori
Ejector
Ejecteurs
Auswerferstifte

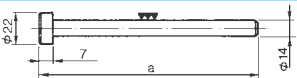

a							
100	125	150	175	200	250	300	350
400	600						

Viti
Screws
Vises

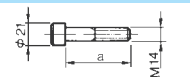

a									
25	30	35	40	45	50	55	60	70	80
90	100	110	120	130	140	150	160	180	200
220	240	260	280	300					

Serie XE 296 x 296

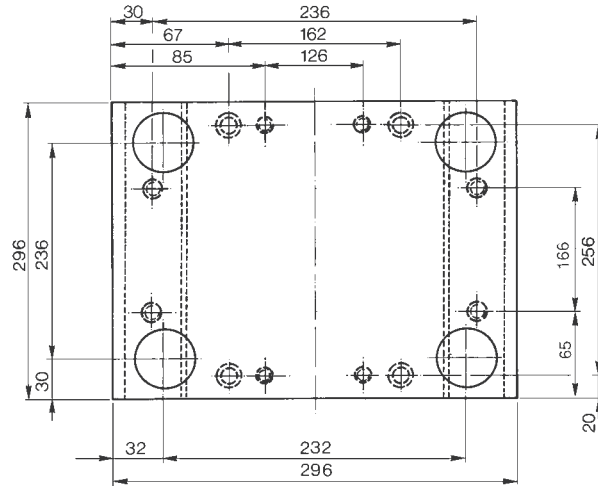
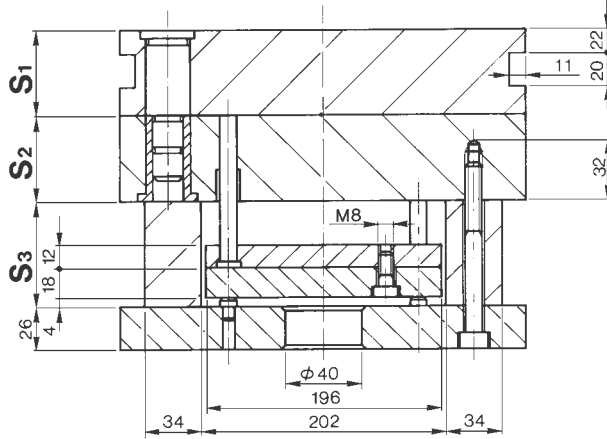

Serie XE + M 296 x 296

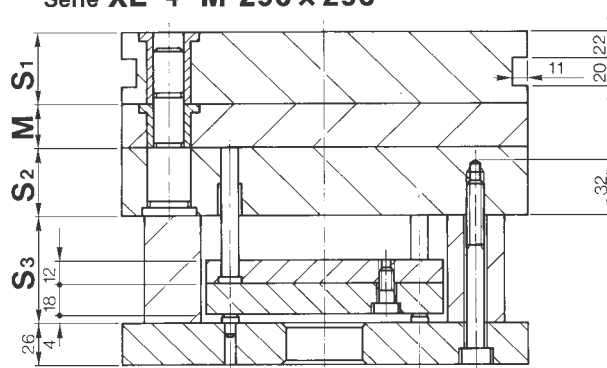

S ₁	S ₂	S ₃	M
46	46	57	36
56	56	77	46
66	66	97	56
76	76		66
96	96		76

Colonne di guida
Guide pins
Colonnes
Präzision Führungssäulen

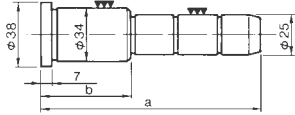

b	a											
26	80	90	100	120	140	160	180	200	220	240	260	280
36												
46												
56												
66												
76												
86												
96												

Bussole di guida
Bushes
Bagues
Führungsbuchse

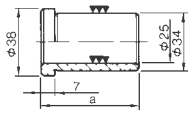

a							
26	36	46	56	66	76	86	96

Bussole di guida
Bushes
Bagues
Führungsbuchse

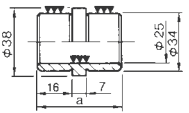

a	
32	40

Espulsori
Ejector
Éjecteurs
Auswerferstifte



a									
100	125	150	175	200	250	300	350	400	600

Viti
Screws
Vises

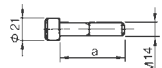

a									
25	30	35	40	45	50	55	60	70	80
90	100	110	120	130	140	150	160	180	200
220	240	260	280	300					

Serie XE 296 x 346

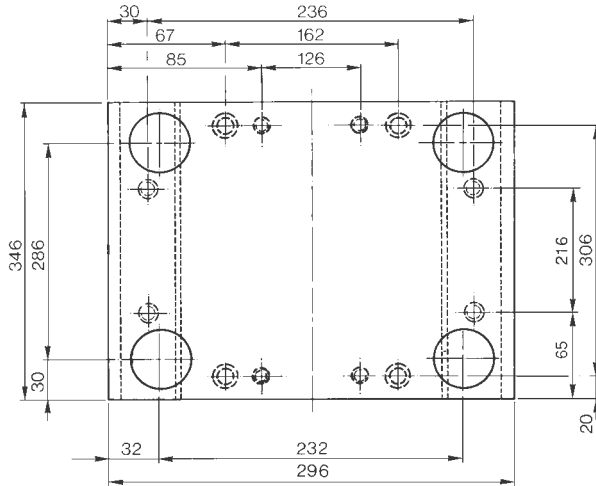
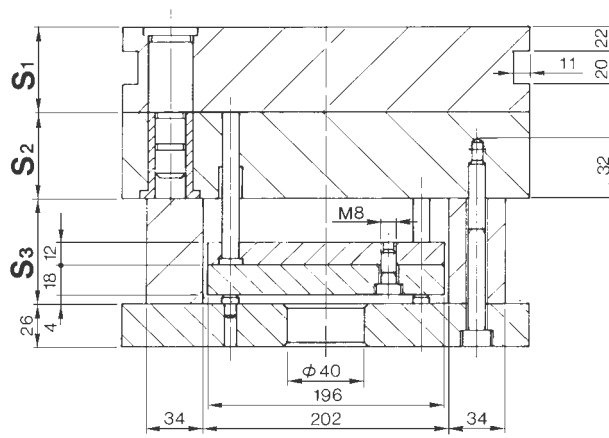

Serie XE + M 296 x 346

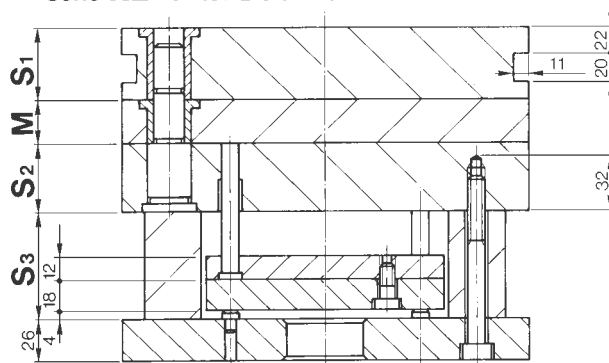

S ₁	S ₂	S ₃	M
46	46	57	36
56	56	77	46
66	66	97	56
76	76		66
96	96		76

Colonne di guida
Guide pins
Colonnes
Präzision Führungssäulen

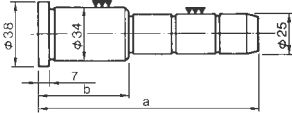

b	a															
26	80	90	100	120	140	160	180	200	220	240	260	280				
36																
46																
56																
66																
76																
86																
96																

Bussole di guida
Bushes
Bagues
Führungsbuchse

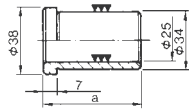

a							
26	36	46	56	66	76	86	96

Bussole di guida
Bushes
Bagues
Führungsbuchse

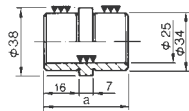

a	
32	40

Espulsori
Ejctor
Ejecteurs
Auswerferstifte

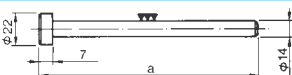

a									
100	125	150	175	200	250	300	350	400	600

Viti
Screws
Vises

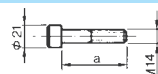

a									
25	30	35	40	45	50	55	60	70	80
90	100	110	120	130	140	150	160	180	200
220	240	260	280	300					

Serie XE 296 x 396

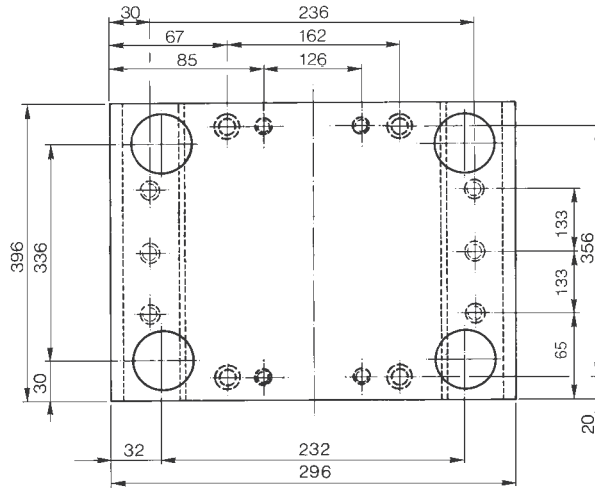
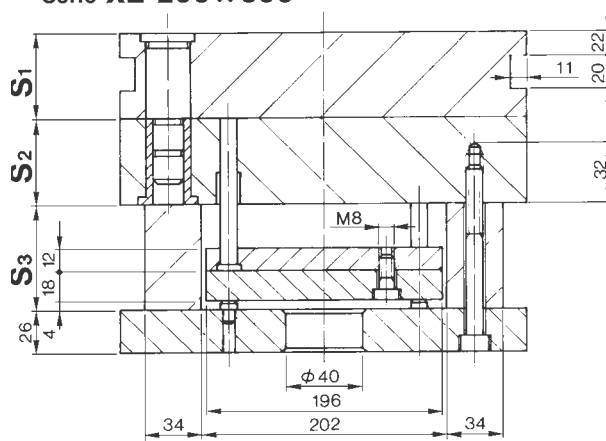

Serie XE + M 296 x 396

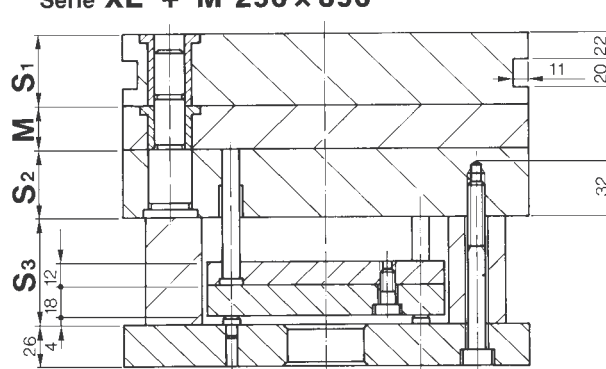

S ₁	S ₂	S ₃	M
46	46	57	36
56	56	77	46
66	66	97	56
76	76		66
96	96		76

Colonne di guida
Guide pins
Colonnes
Präzision Führungssäulen

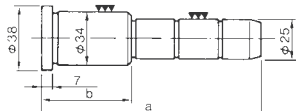

b	a															
26	80	90	100	120	140	160	180	200	220	240	260	280				
36																
46																
56																
66																
76																
86																
96																

Bussole di guida
Bushes
Bagues
Führungsbuchse

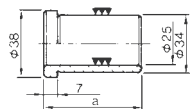

a							
26	36	46	56	66	76	86	96

Bussole di guida
Bushes
Bagues
Führungsbuchse

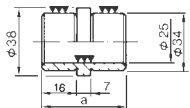

a	
32	40

Espulsori
Ejector
Éjecteurs
Auswerferstifte



a									
100	125	150	175	200	250	300	350	400	600

Viti
Screws
Vises

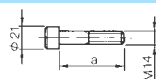

a									
25	30	35	40	45	50	55	60	70	80
90	100	110	120	130	140	150	160	180	200
220	240	260	280	300					

Serie XE 296 x 446

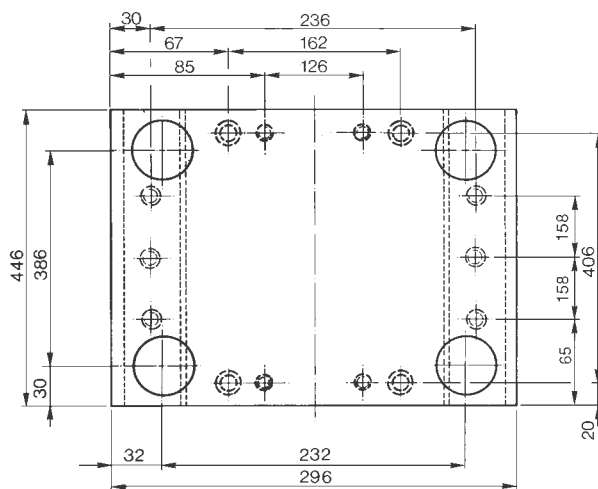
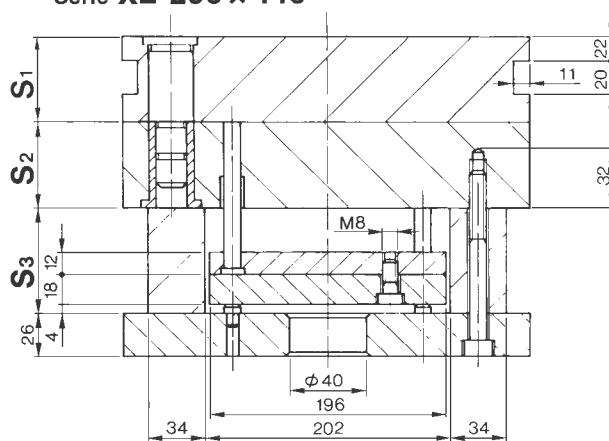

Serie XE + M 296 x 446

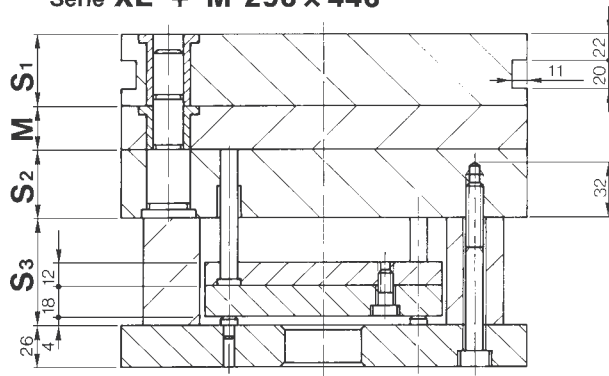

S ₁	S ₂	S ₃	M
56	56	57	36
66	66	77	46
76	76	97	56
96	96		66

Colonne di guida
Guide pins
Colonnes
Präzision Führungssäulen

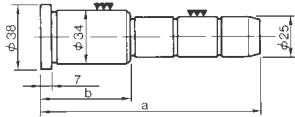

b	a												
26	80	90	100	120	140	160	180	200	220	240	260	280	
36													
46													
56													
66													
76													
86													
96													

Bussole di guida
Bushes
Bagues
Führungsbuchse

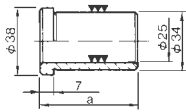

a							
26	36	46	56	66	76	86	96

Bussole di guida
Bushes
Bagues
Führungsbuchse

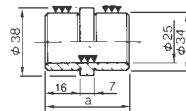

a	
32	40

Espulsori
Ejector
Ejecteurs
Auswerferstifte

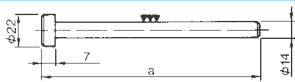

a									
100	125	150	175	200	250	300	350	400	600

Viti
Screws
Vises

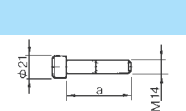

a									
25	30	35	40	45	50	55	60	70	80
90	100	110	120	130	140	150	160	180	200
220	240	260	280	300					

Serie XE 346 x 346

Serie XE + M 346 x 346

S ₁	S ₂	S ₃	M
56	56	57	36
66	66	77	46
76	76	97	56
96	96		66
116	116		76

Colonne di guida
Guide pins
Colonnes
Präzision Führungssäulen

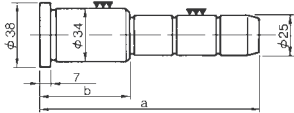

b	a											
80	90	100	120	140	160	180	200	220	240	260	280	
26												
36												
46												
56												
66												
76												
86												
96												

Bussole di guida
Bushes
Bagues
Führungsbuchse

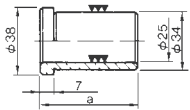

a							
26	36	46	56	66	76	86	96

Bussole di guida
Bushes
Bagues
Führungsbuchse

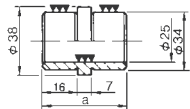

a	
32	40

Espulsori
Ejector
Ejecteurs
Auswerferstifte

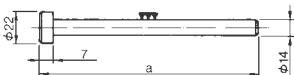

a									
100	125	150	175	200	250	300	350	400	600

Viti
Screws
Vises

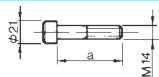

a											
25	30	35	40	45	50	55	60	70	80		
90	100	110	120	130	140	150	160	180	200		
220	240	260	280	300							

Serie XE 346 x 396

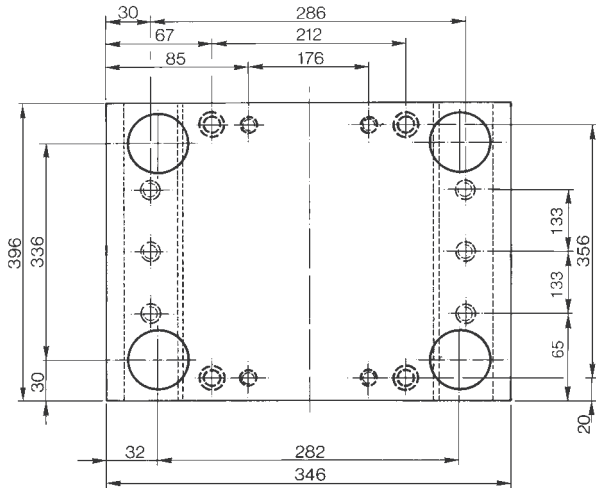
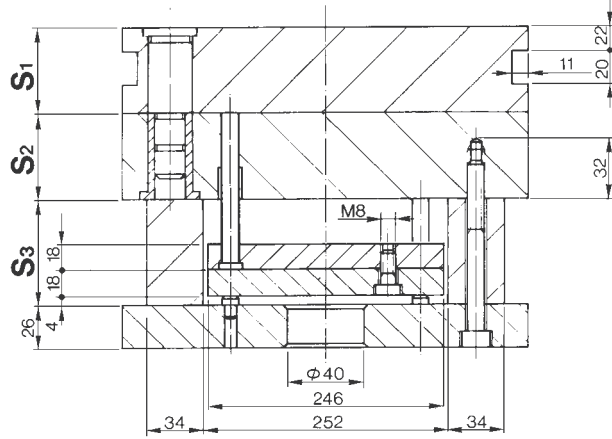

Serie XE + M 346 x 396

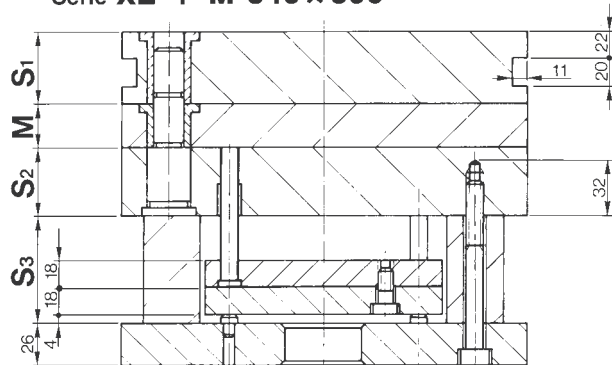

S ₁	S ₂	S ₃	M
56	56	57	36
66	66	77	46
76	76	97	56
96	96		66
116	116		76

Colonne di guida
Guide pins
Colonnes
Präzision Führungssäulen

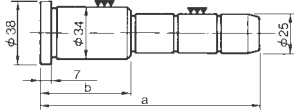

b	a											
	80	90	100	120	140	160	180	200	220	240	260	280
26												
36												
46												
56												
66												
76												
86												
96												

Bussole di guida
Bushes
Bagues
Führungsbuchse

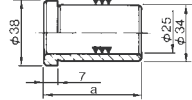

a							
26	36	46	56	66	76	86	96

Bussole di guida
Bushes
Bagues
Führungsbuchse

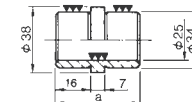

a	
32	40

Espulsori
Ejector
Ejecteurs
Auswerferstifte

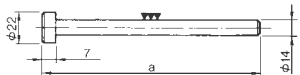

a							
100	125	150	175	200	250	300	350
400	600						

Viti
Screws
Vises

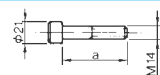

a									
25	30	35	40	45	50	55	60	70	80
90	100	110	120	130	140	150	160	180	200
220	240	260	280	300					

Serie XE 346 x 446

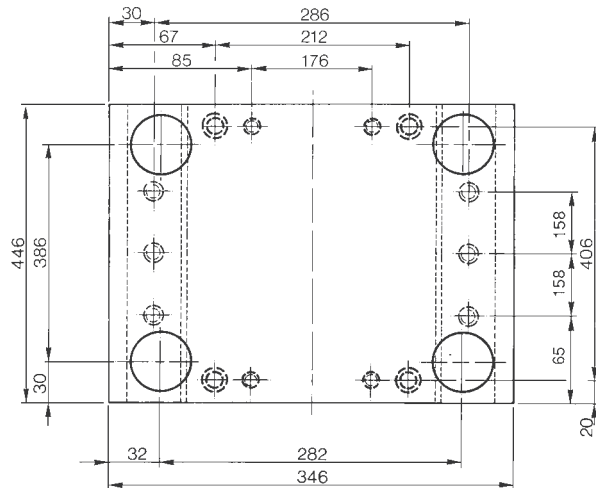
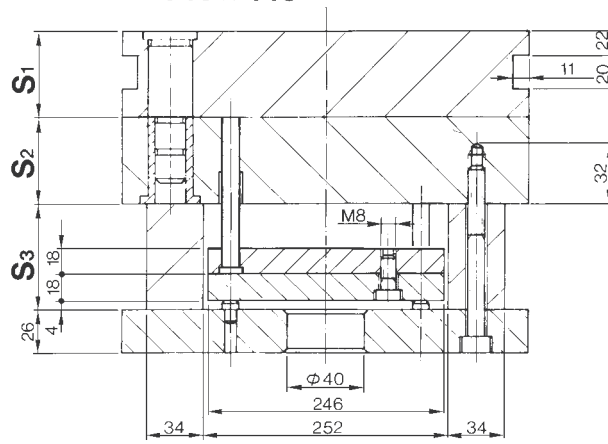

Serie XE + M 346 x 446

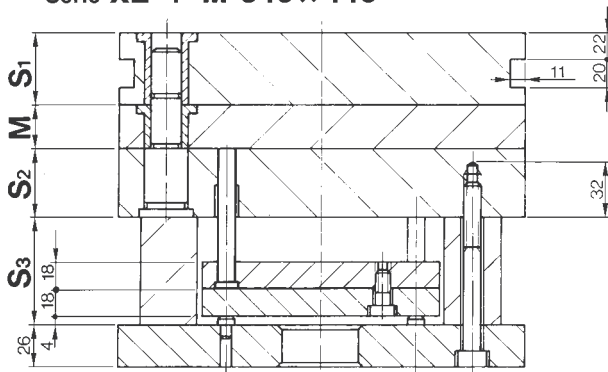

S ₁	S ₂	S ₃	M
56	56	57	36
66	66	77	46
76	76	97	56
96	96		66
116	116		76

Colonne di guida
Guide pins
Colonnes
Präzision Führungssäulen

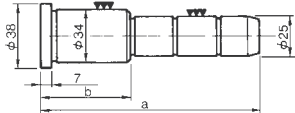

b	a												
80	90	100	120	140	160	180	200	220	240	260	280		
26													
36													
46													
56													
66													
76													
86													
96													

Bussole di guida
Bushes
Bagues
Führungsbuchse

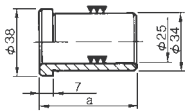

a							
26	36	46	56	66	76	86	96

Bussole di guida
Bushes
Bagues
Führungsbuchse

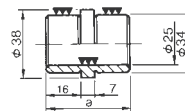

a	
32	40

Espulsori
Ejector
Éjecteurs
Auswerferstifte

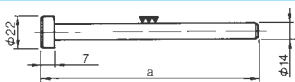

a									
100	125	150	175	200	250	300	350	400	600

Viti
Screws
Vises

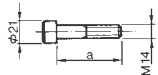

a									
25	30	35	40	45	50	55	60	70	80
90	100	110	120	130	140	150	160	180	200
220	240	260	280	300					

Serie XE 346 x 496

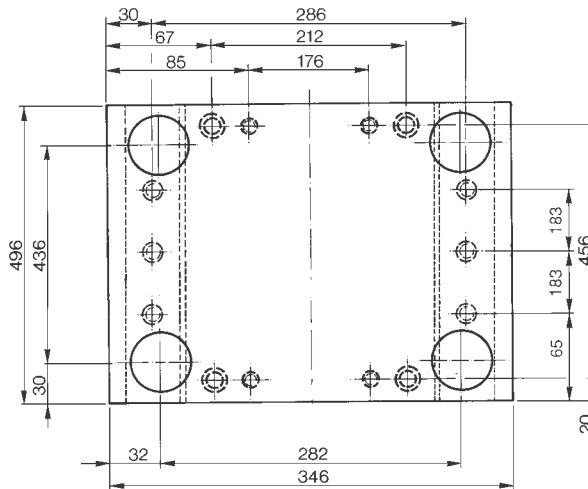
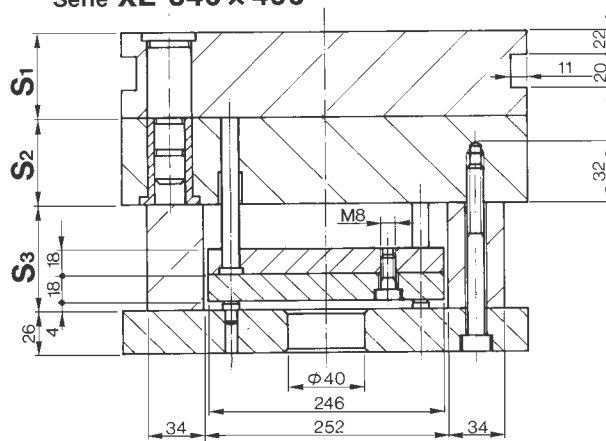

Serie XE + M 346 x 496

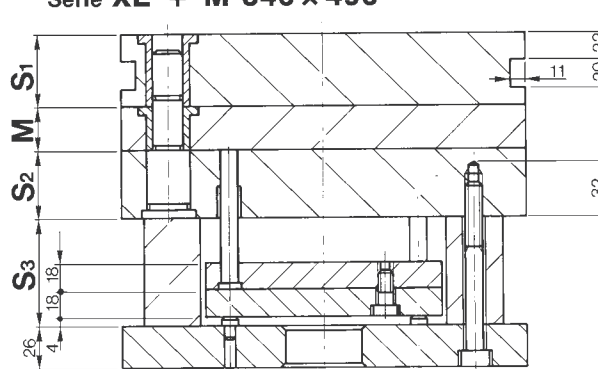

S ₁	S ₂	S ₃	M
56	56	57	36
66	66	77	46
76	76	97	56
96	96		66
116	116		76

Colonne di guida
Guide pins
Colonnes
Präzision Führungssäulen

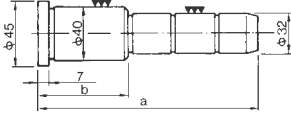

b	a										
80	90	100	120	140	160	180	200	220	240	260	280
36											
46											
56											
66											
76											
86											
96											
106											

Bussole di guida
Bushes
Bagues
Führungsbuchse

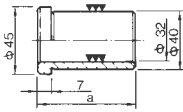

a							
36	46	56	66	76	86	96	106

Bussole di guida
Bushes
Bagues
Führungsbuchse

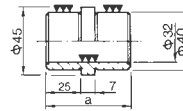

a	
50	65

Espulsori
Ejector
Ejecteurs
Auswerferstifte

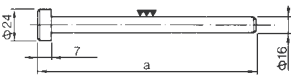

a									
100	125	150	175	200	250	300	350	400	600

Viti
Screws
Vises

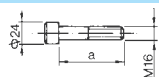

a										
25	30	35	40	45	50	55	60	70	80	
90	100	110	120	130	140	150	160	180	200	
220	240	260	280	300						

Serie XE 396 x 446

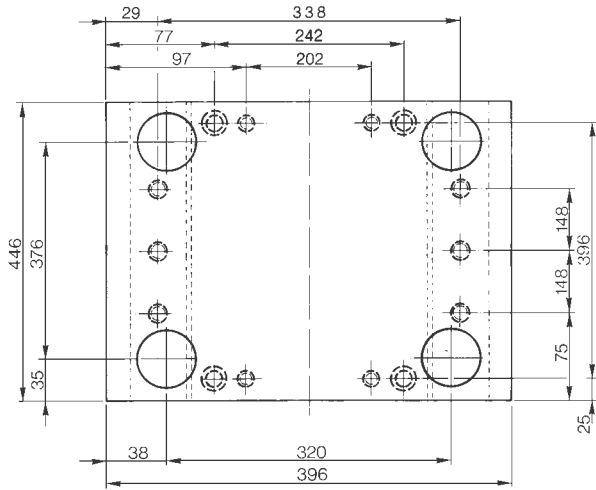
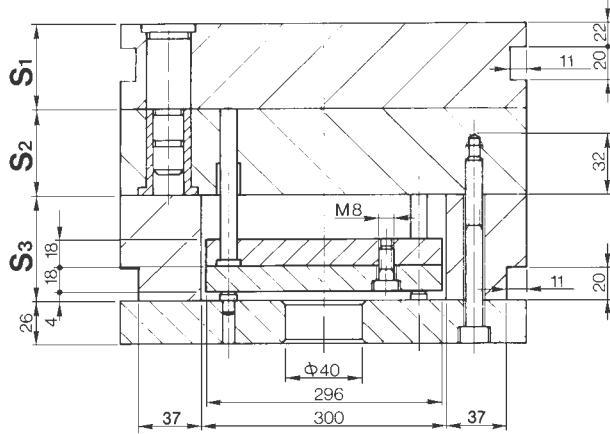

Serie XE + M 396 x 446

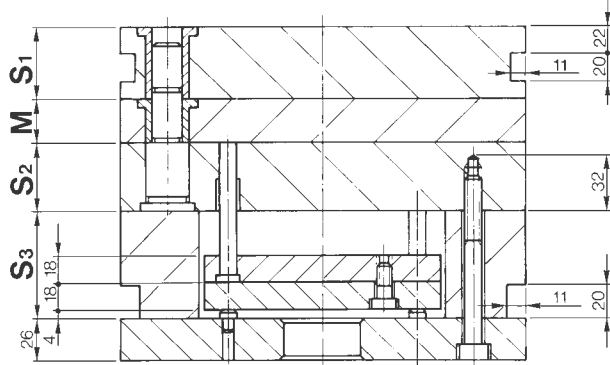

S ₁	S ₂	S ₃	M
56	56	57	46
66	66	77	56
76	76	97	66
96	96		76
116	116		96

Colonne di guida
Guide pins
Colonnes
Präzision Führungssäulen

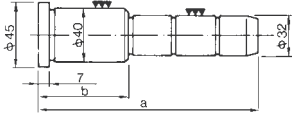

b	a																						
	80	90	100	120	140	160	180	200	220	240	260	280											
36																							
46																							
56																							
66																							
76																							
86																							
96																							
106																							

Bussole di guida
Bushes
Bagues
Führungsbuchse

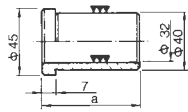

a									
36	46	56	66	76	86	96	106		

Bussole di guida
Bushes
Bagues
Führungsbuchse

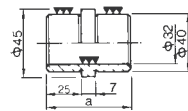

a	
50	65

Espulsori
Ejctor
Ejecteurs
Auswerferstifte

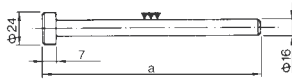

a									
100	125	150	175	200	250	300	350	400	600

Viti
Screws
Vises

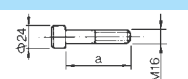

a												
25	30	35	40	45	50	55	60	70	80			
90	100	110	120	130	140	150	160	180	200			
220	240	260	280	300								

Serie XE 396 x 496

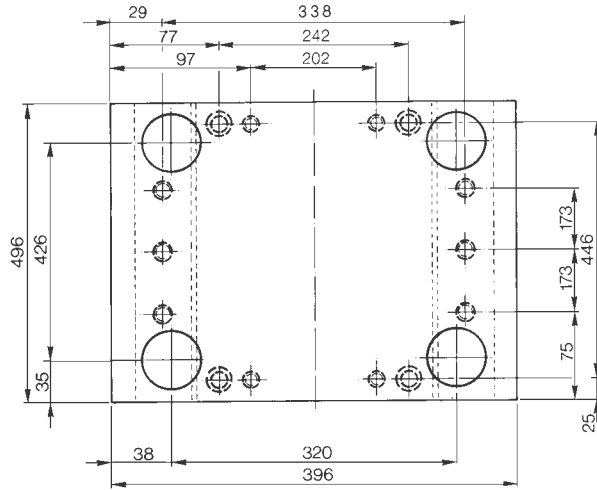
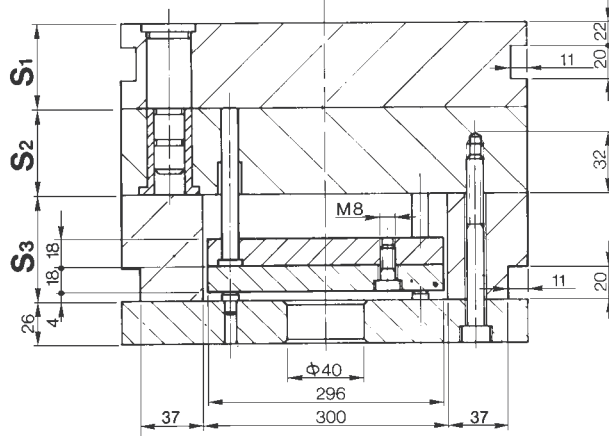

Serie XE + M 396 x 496

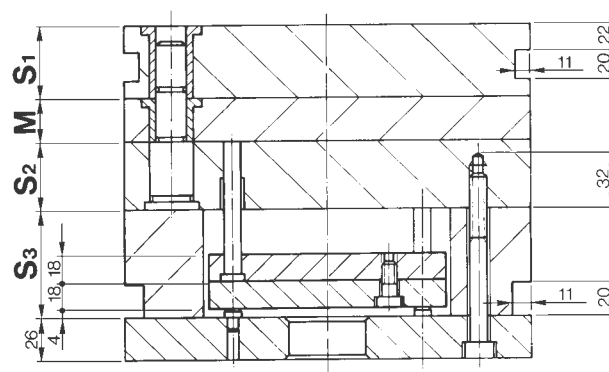

S ₁	S ₂	S ₃	M
66	66	57	56
76	76	77	66
96	96	97	76
116	116		96

Colonne di guida
Guide pins
Colonnes
Präzision Führungssäulen

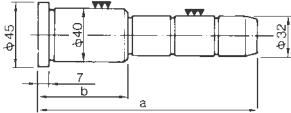

b	a										
80	90	100	120	140	160	180	200	220	240	260	280
36											
46											
56											
66											
76											
86											
96											
106											

Bussole di guida
Bushes
Bagues
Führungsbuchse

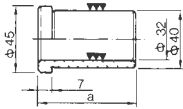

a							
36	46	56	66	76	86	96	106

Bussole di guida
Bushes
Bagues
Führungsbuchse

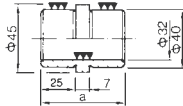

a	
50	65

Espulsori
Ejector
Éjecteurs
Auswerferstifte

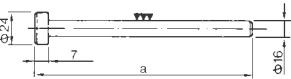

a									
100	125	150	175	200	250	300	350	400	600

Viti
Screws
Vises

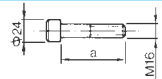

a										
25	30	35	40	45	50	55	60	70	80	
90	100	110	120	130	140	150	160	180	200	
220	240	260	280	300						

Serie XE 396 x 546

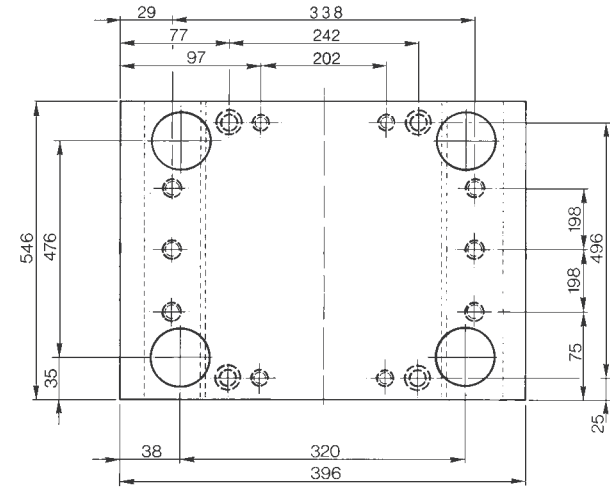
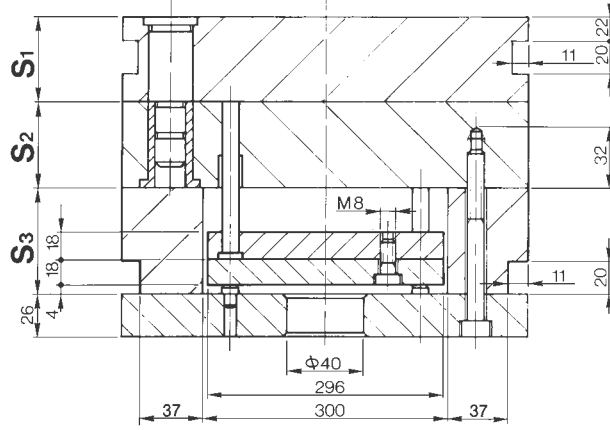

Serie XE + M 396 x 546

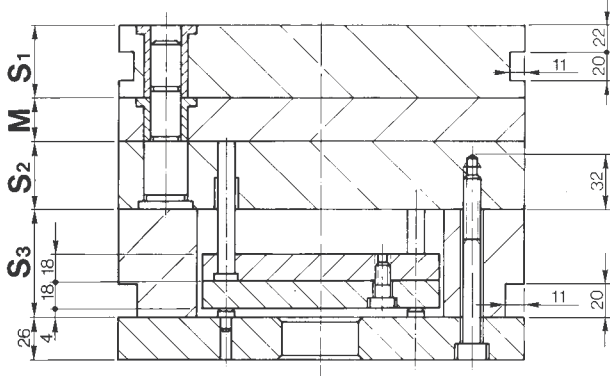

S ₁	S ₂	S ₃	M
66	66	57	56
76	76	77	66
96	96	97	76
116	116		96

Colonne di guida
Guide pins
Colonnes
Präzision Führungssäulen

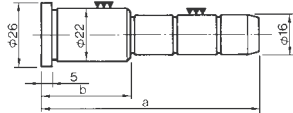

b	a														
	50	60	70	80	90	100	120	140	160	180	200				
22															
26															
36															
46															
56															

Bussole di guida
Bushes
Bagues
Führungsbuchse

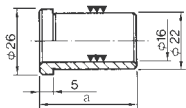

a						
22	26	36	46	56	66	76

Bussole di guida
Bushes
Bagues
Führungsbuchse

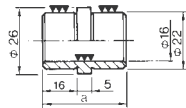

a	
32	40

Espulsori
Ejector
Éjecteurs
Auswerferstifte

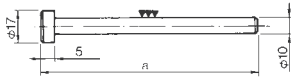

a									
100	125	150	175	200	250	300	350	400	600

Viti
Screws
Vises

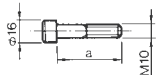

a												
16	18	20	25	30	35	40	45	50	55			
60	70	80	90	100	110	120	130	140	150			
160	180	200	220	240	260	280	300					

Serie X 156 x 156

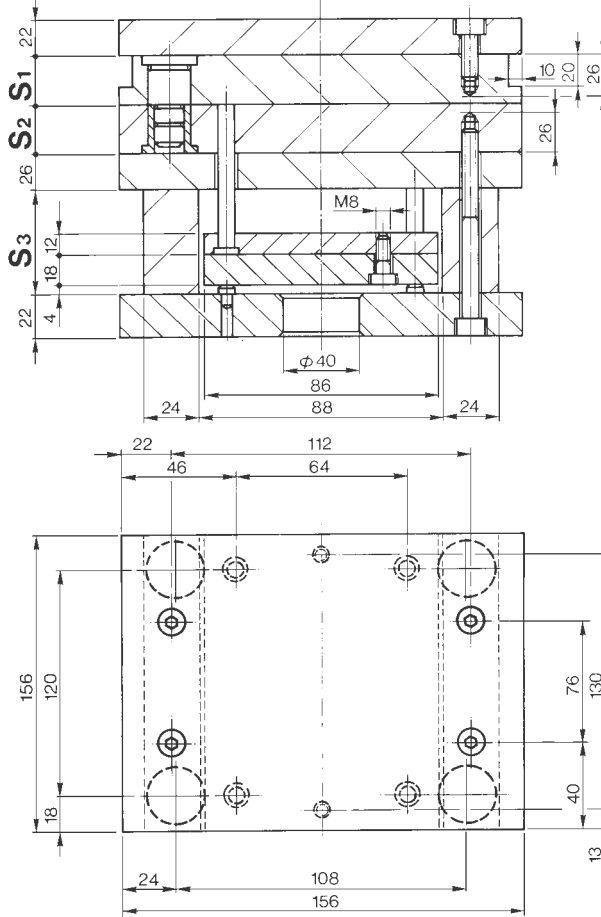

Serie X + M 156 x 156

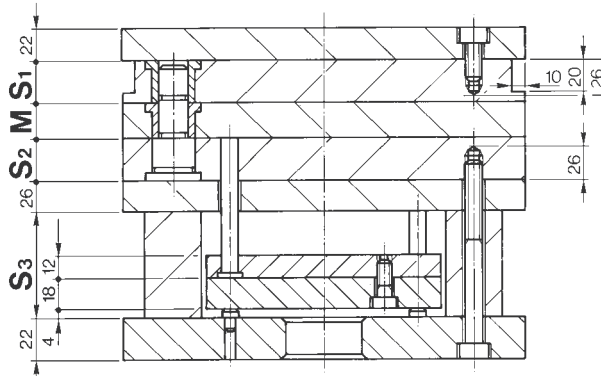

S ₁	S ₂	S ₃	M
26	26	57	26
36	36	77	36
46	46		46
56	56		56

Colonne di guida
Guide pins
Colonnes
Präzision Führungssäulen

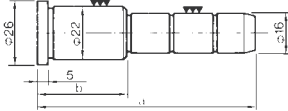

b	a										
	50	60	70	80	90	100	120	140	160	180	200
22											
26											
36											
46											
56											

Bussole di guida
Bushes
Bagues
Führungsbuchse

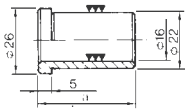

a						
22	26	36	46	56	66	76

Bussole di guida
Bushes
Bagues
Führungsbuchse

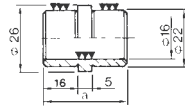

a	
32	40

Espulsori
Ejector
Éjecteurs
Auswerferstifte

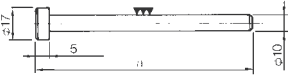

a									
100	125	150	175	200	250	300	350	400	600

Viti
Screws
Vises

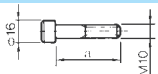

a										
16	18	20	25	30	35	40	45	50	55	
60	70	80	90	100	110	120	130	140	150	
160	180	200	220	240	260	280	300			

Serie X 156 x 196

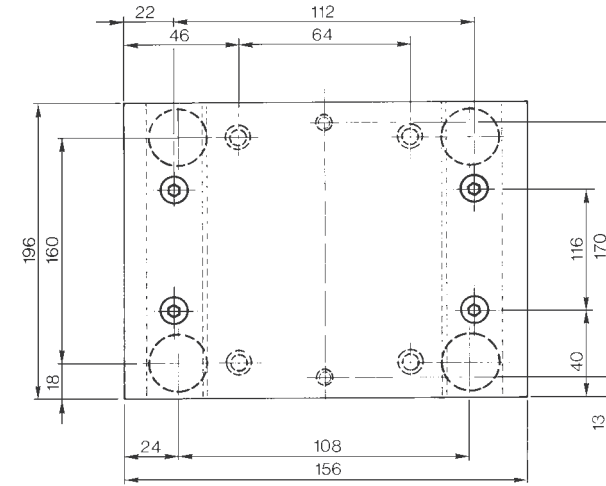
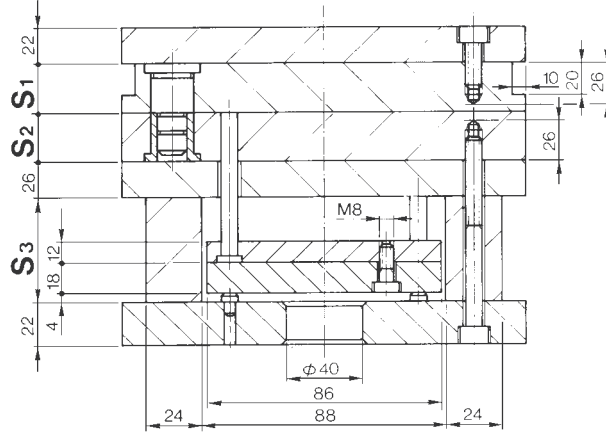

Serie X + M 156 x 196

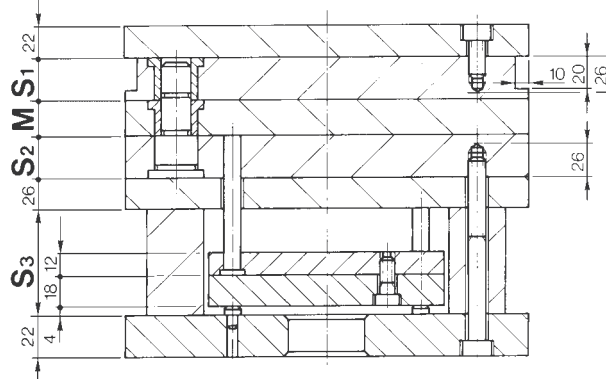

S ₁	S ₂	S ₃	M
26	26	57	26
36	36	77	36
46	46		46
56	56		56

Colonne di guida
Guide pins
Colonnes
Präzision Führungssäulen

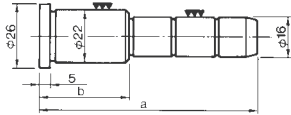

b	a										
	50	60	70	80	90	100	120	140	160	180	200
22											
26											
36											
46											
56											

Bussole di guida
Bushes
Bagues
Führungsbuchse

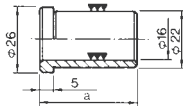

a						
22	26	36	46	56	66	76

Bussole di guida
Bushes
Bagues
Führungsbuchse

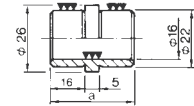

a	
32	40

Espulsori
Ejector
Ejecteurs
Auswerferstifte

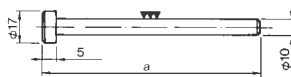

a									
100	125	150	175	200	250	300	350	400	600

Viti
Screws
Vises

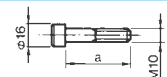

a												
16	18	20	25	30	35	40	45	50	55			
60	70	80	90	100	110	120	130	140	150			
160	180	200	220	240	260	280	300					

Serie X 156 x 246

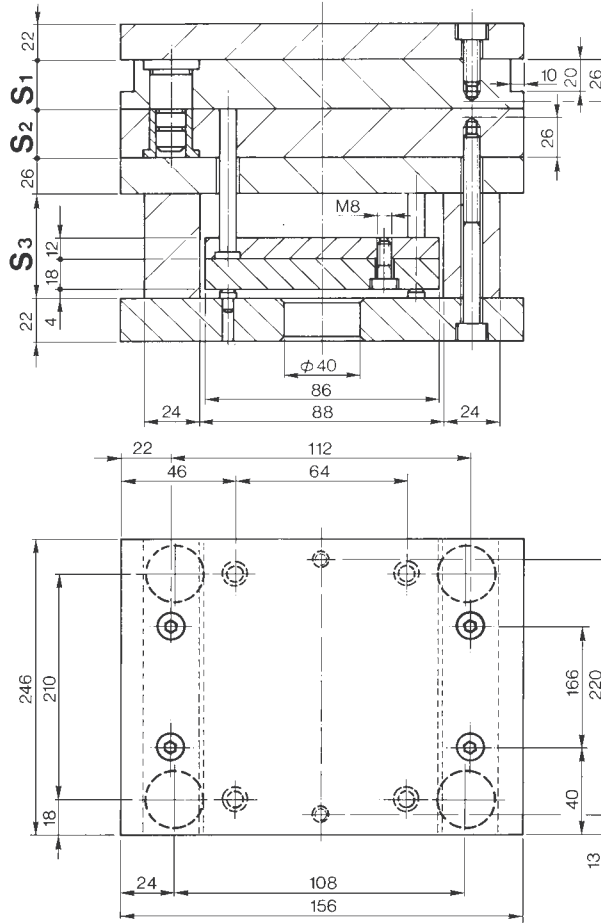

Serie X + M 156 x 246

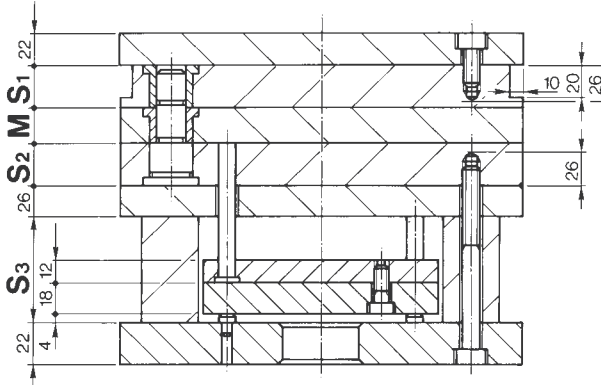

S ₁	S ₂	S ₃	M
26	26	57	26
36	36	77	36
46	46		46
56	56		56

Colonne di guida
Guide pins
Colonnes
Präzision Führungssäulen

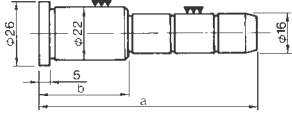

b	a											
	50	60	70	80	90	100	120	140	160	180	200	
22												
26												
36												
46												
56												

Bussole di guida
Bushes
Bagues
Führungsbuchse

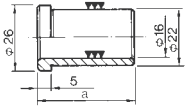

a						
22	26	36	46	56	66	76

Bussole di guida
Bushes
Bagues
Führungsbuchse

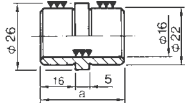

a	
32	40

Espulsori
Ejctor
Éjecteurs
Auswerferstifte

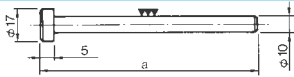

a									
100	125	150	175	200	250	300	350	400	600

Viti
Screws
Vises

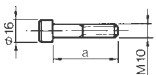

a												
16	18	20	25	30	35	40	45	50	55			
60	70	80	90	100	110	120	130	140	150			
160	180	200	220	240	260	280	300					

Serie X 196 x 196

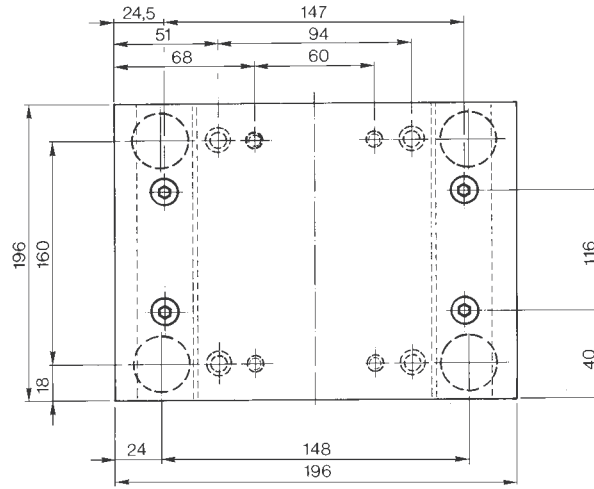
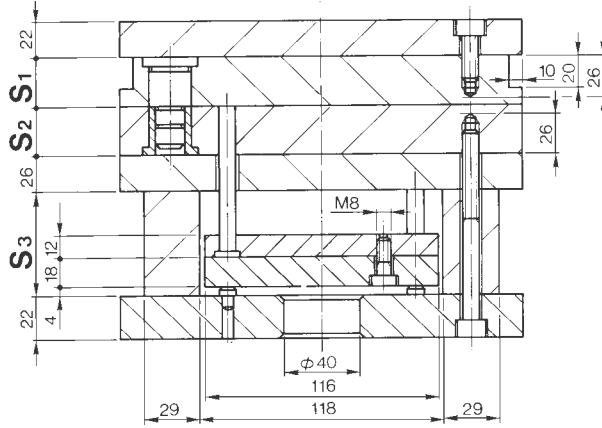

Serie X + M 196 x 196

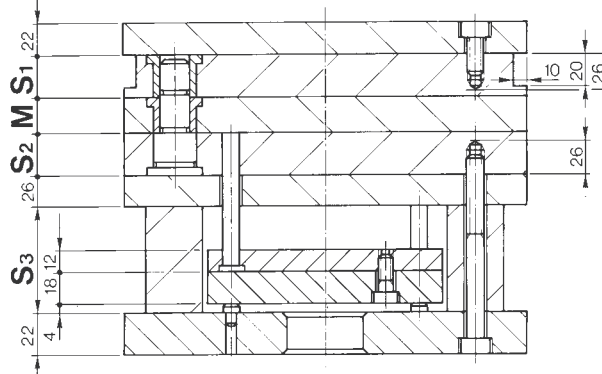

S ₁	S ₂	S ₃	M
26	26	57	26
36	36	77	36
46	46	97	46
56	56		56
66	66		66

Colonne di guida
Guide pins
Colonnes
Präzision Führungssäulen

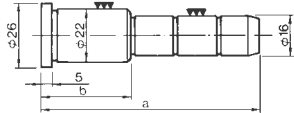

b	a																	
	50	60	70	80	90	100	120	140	160	180	200							
22																		
26																		
36																		
46																		
56																		

Bussole di guida
Bushes
Bagues
Führungsbuchse

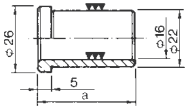

a							
22	26	36	46	56	66	76	

Bussole di guida
Bushes
Bagues
Führungsbuchse

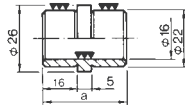

a	
32	40

Espulsori
Ejector
Ejecteurs
Auswerferstifte

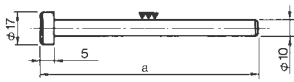

a									
100	125	150	175	200	250	300	350	400	600

Viti
Screws
Vises

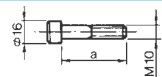

a												
16	18	20	25	30	35	40	45	50	55			
60	70	80	90	100	110	120	130	140	150			
160	180	200	220	240	260	280	300					

Serie X 196 x 246

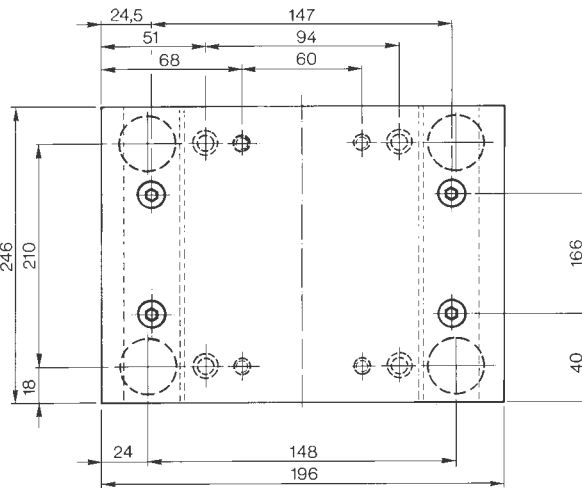
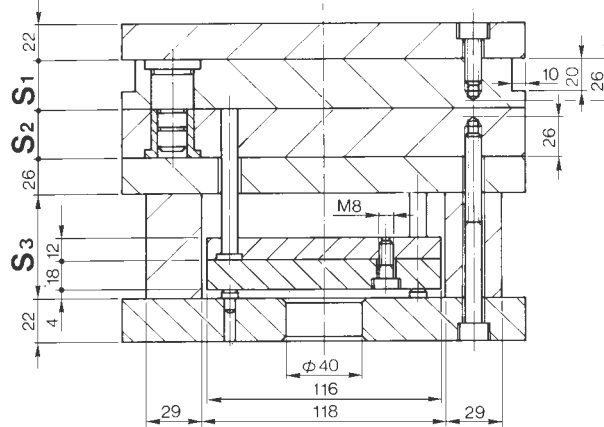

Serie X + M 196 x 246

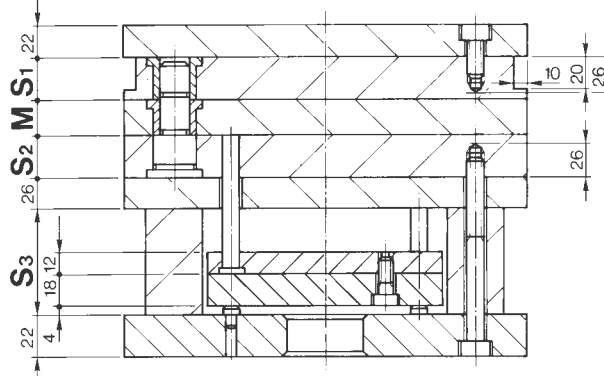

S ₁	S ₂	S ₃	M
26	26	57	26
36	36	77	36
46	46	97	46
56	56		56
66	66		66

Colonne di guida
Guide pins
Colonnes
Präzision Führungssäulen

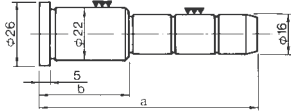

b	a																	
	50	60	70	80	90	100	120	140	160	180	200							
22																		
26																		
36																		
46																		
56																		

Bussole di guida
Bushes
Bagues
Führungsbuchse

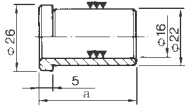

a						
22	26	36	46	56	66	76

Bussole di guida
Bushes
Bagues
Führungsbuchse

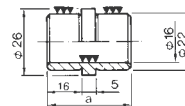

a	
32	40

Espulsori
Ejctor
Ejecteurs
Auswerferstifte

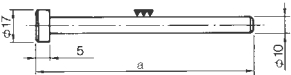

a									
100	125	150	175	200	250	300	350	400	600

Viti
Screws
Vises

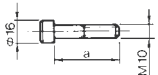

a												
16	18	20	25	30	35	40	45	50	55			
60	70	80	90	100	110	120	130	140	150			
160	180	200	220	240	260	280	300					

Serie X 196 x 296

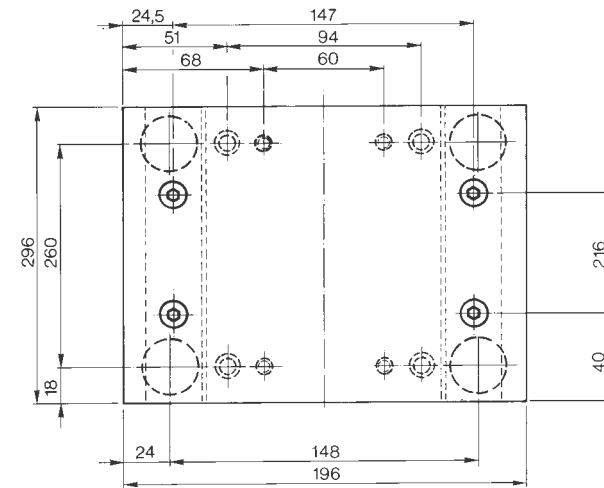
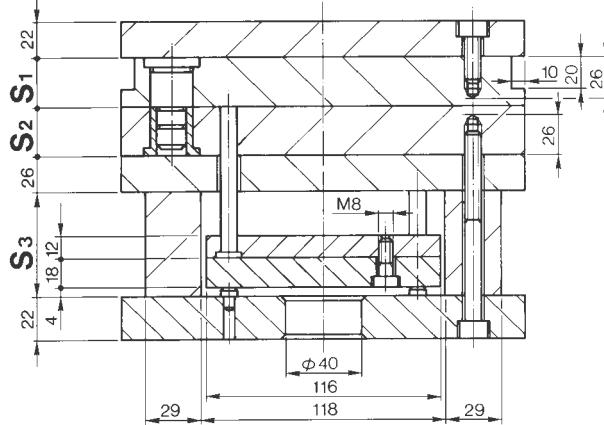

Serie X + M 196 x 296

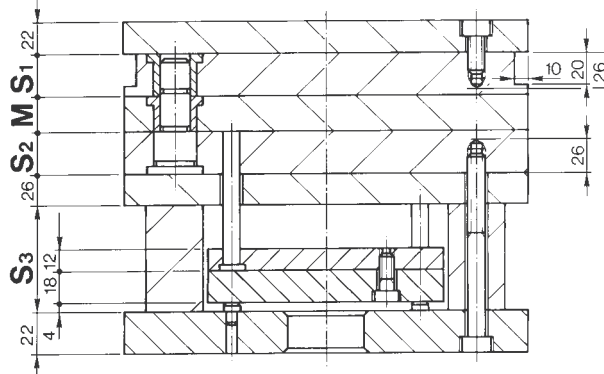

S ₁	S ₂	S ₃	M
26	26	57	26
36	36	77	36
46	46	97	46
56	56		56
66	66		66

Colonne di guida
Guide pins
Colonnes
Präzision Führungssäulen

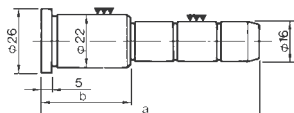

b	a																
	50	60	70	80	90	100	120	140	160	180	200						
22																	
26																	
36																	
46																	
56																	

Bussole di guida
Bushes
Bagues
Führungsbuchse

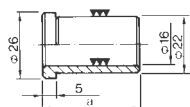

a							
22	26	36	46	56	66	76	

Bussole di guida
Bushes
Bagues
Führungsbuchse

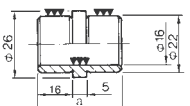

a	
32	40

Espulsori
Ejector
Éjecteurs
Auswerferstifte

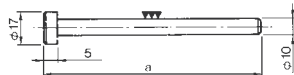

a									
100	125	150	175	200	250	300	350	400	600

Viti
Screws
Vises

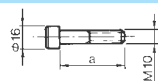

a												
16	18	20	25	30	35	40	45	50	55			
60	70	80	90	100	110	120	130	140	150			
160	180	200	220	240	260	280	300					

Serie X 196 x 346

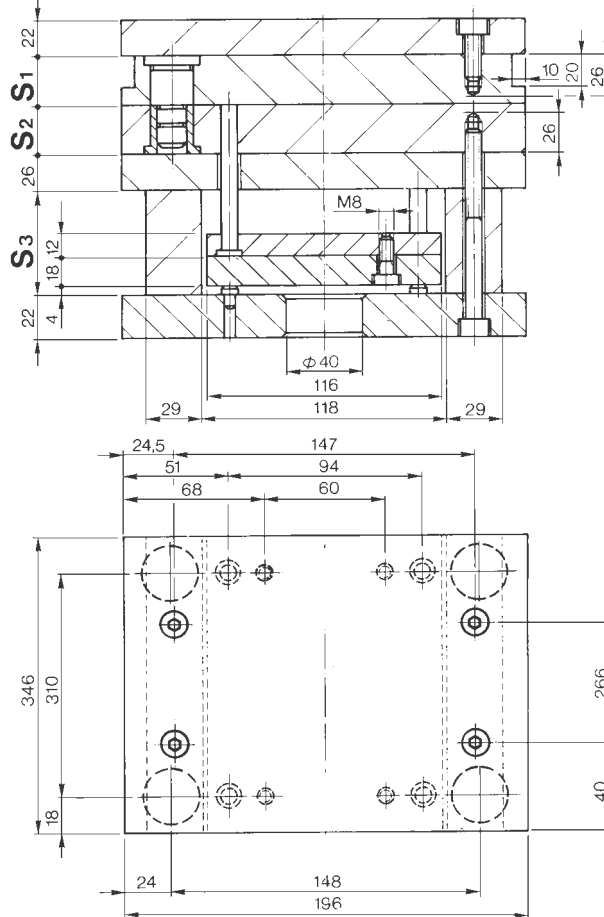

Serie X + M 196 x 346

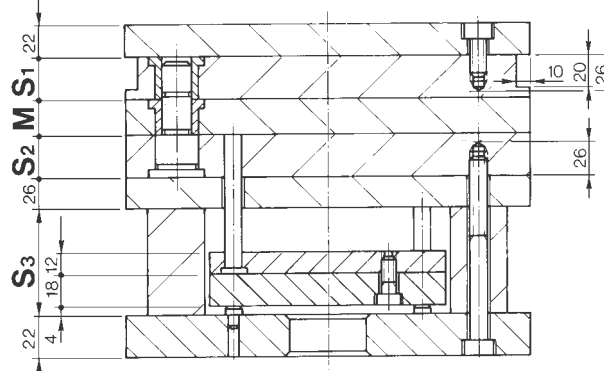

S ₁	S ₂	S ₃	M
26	26	57	26
36	36	77	36
46	46	97	46
56	56		56
66	66		66

Colonne di guida
Guide pins
Colonnes
Prazision Fuhrungssaulen

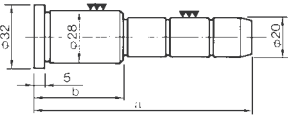

b	a										
	50	60	70	80	90	100	120	140	160	180	200
26											
36											
46											
56											
66											
76											

Bussole di guida
Bushes
Bagues
Fuhrungsbuchse

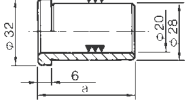

a
22
26
36
46
56
66
76
96

Bussole di guida
Bushes
Bagues
Fuhrungsbuchse

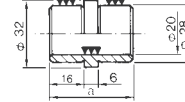

a
32
40

Espulsori
Ejtor
Ejecteurs
Auswerferstifte

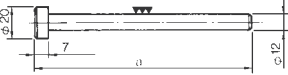

a
100
125
150
175
200
250
300
350
400
600

Viti
Screws
Vises

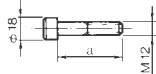

a										
16	18	20	25	30	35	40	45	50	55	
60	70	80	90	100	110	120	130	140	150	
160	180	200	220	240	260	280	300			

Serie X 246 x 246

Serie X + M 246 x 246

S ₁	S ₂	S ₃	M
26	26	57	26
36	36	77	36
46	46	97	46
56	56		56
66	66		66

Colonne di guida
Guide pins
Colonnes
Präzision Führungssäulen

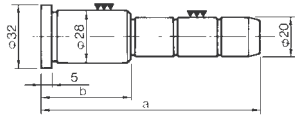

b	a										
	50	60	70	80	90	100	120	140	160	180	200
26											
36											
46											
56											
66											
76											

Bussole di guida
Bushes
Bagues
Führungsbuchse

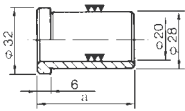

a							
22	26	36	46	56	66	76	96

Bussole di guida
Bushes
Bagues
Führungsbuchse

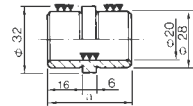

a	
32	40

Espulsori
Ejector
Ejecteurs
Auswerferstifte



a									
100	125	150	175	200	250	300	350	400	600

Viti
Screws
Vises

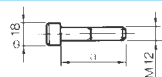

a									
16	18	20	25	30	35	40	45	50	55
60	70	80	90	100	110	120	130	140	150
160	180	200	220	240	260	280	300		

Serie X 246 x 296

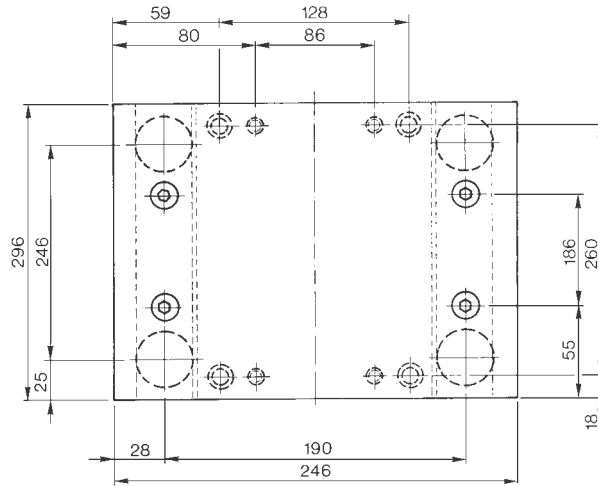
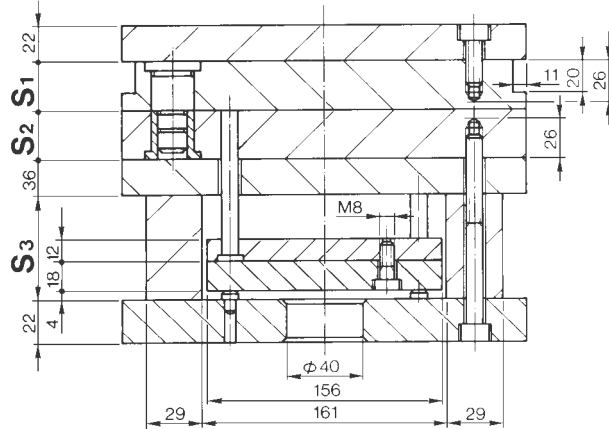

Serie X + M 246 x 296

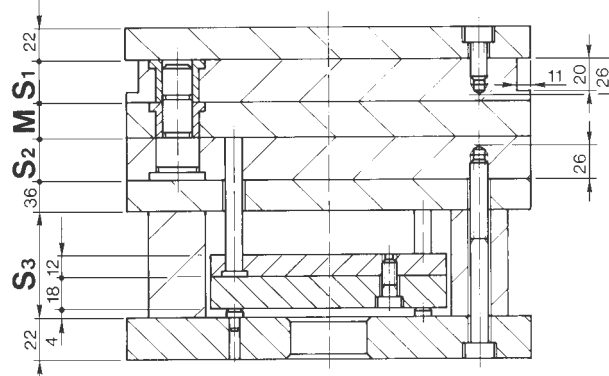

S ₁	S ₂	S ₃	M
26	26	57	26
36	36	77	36
46	46	97	46
56	56		56
66	66		66

Colonne di guida
Guide pins
Colonnes
Präzision Führungssäulen

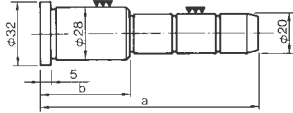

b	a										
	50	60	70	80	90	100	120	140	160	180	200
26											
36											
46											
56											
66											
76											

Bussole di guida
Bushes
Bagues
Führungsbuchse

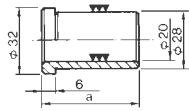

a
22
26
36
46
56
66
76
96

Bussole di guida
Bushes
Bagues
Führungsbuchse

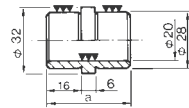

a
32
40

Espulsori
Ejector
Ejecteurs
Auswerferstifte

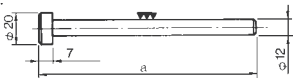

a
100
125
150
175
200
250
300
350
400
600

Viti
Screws
Vises

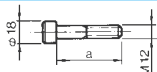

a										
16	18	20	25	30	35	40	45	50	55	
60	70	80	90	100	110	120	130	140	150	
160	180	200	220	240	260	280	300			

Serie X 246 x 346

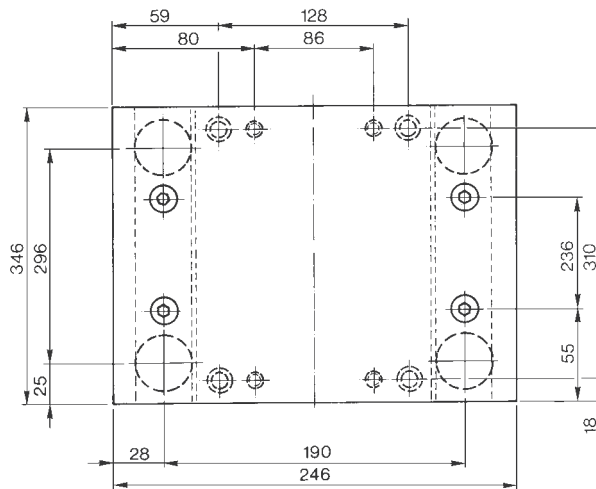
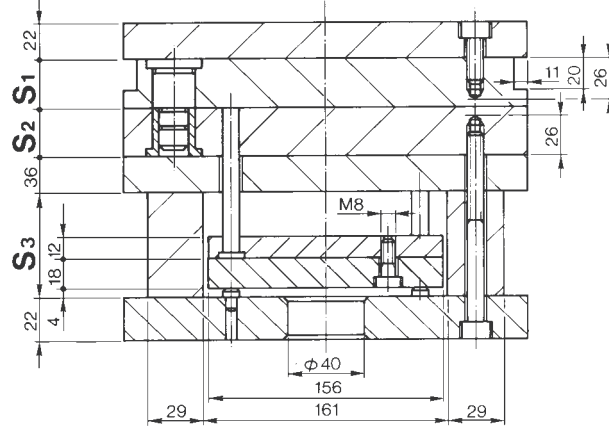

Serie X + M 246 x 346

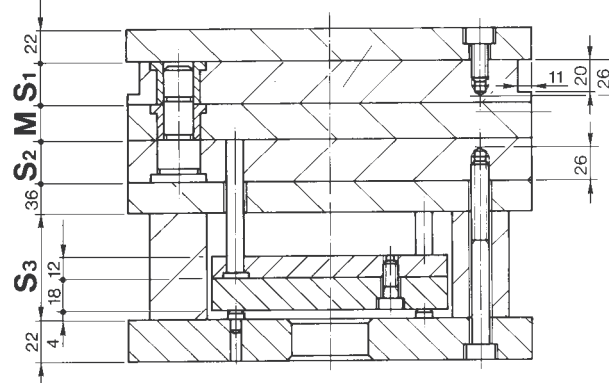

S ₁	S ₂	S ₃	M
26	26	57	26
36	36	77	36
46	46	97	46
56	56		56
66	66		66

Colonne di guida
Guide pins
Colonnes
Präzision Führungssäulen

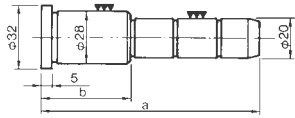

b	a										
	50	60	70	80	90	100	120	140	160	180	200
26											
36											
46											
56											
66											
76											

Bussole di guida
Bushes
Bagues
Führungsbuchse

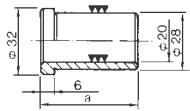

a
22
26
36
46
56
66
76
96

Bussole di guida
Bushes
Bagues
Führungsbuchse

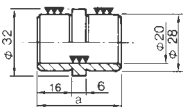

a
32
40

Espulsori
Ejector
Éjecteurs
Auswerferstifte

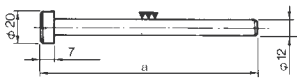

a
100
125
150
175
200
250
300
350
400
600

Viti
Screws
Vises

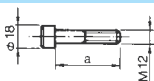

a										
16	18	20	25	30	35	40	45	50	55	
60	70	80	90	100	110	120	130	140	150	
160	180	200	220	240	260	280	300			

Serie X 246 x 396

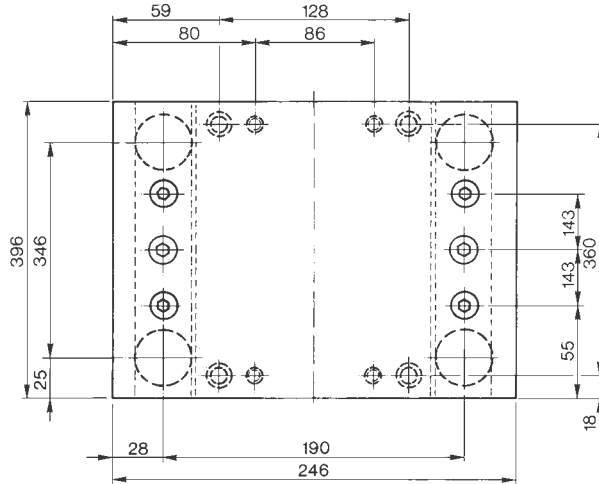
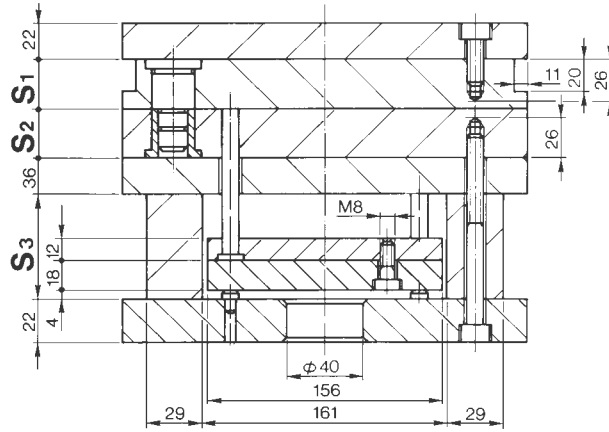

Serie X + M 246 x 396

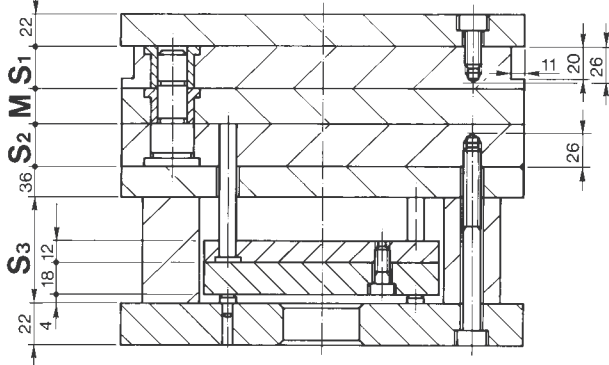

S ₁	S ₂	S ₃	M
26	26	57	26
36	36	77	36
46	46	97	46
56	56		56
66	66		66

Colonne di guida
Guide pins
Colonnes
Präzision Führungssäulen

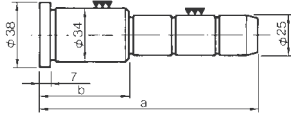

b	a																
26	80	90	100	120	140	160	180	200	220	240	260	280					
36																	
46																	
56																	
66																	
76																	
86																	
96																	

Bussole di guida
Bushes
Bagues
Führungsbuchse

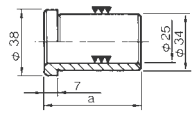

a							
26	36	46	56	66	76	86	96

Bussole di guida
Bushes
Bagues
Führungsbuchse

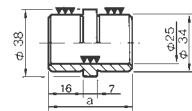

a	
32	40

Espulsori
Ejector
Éjecteurs
Auswerferstifte

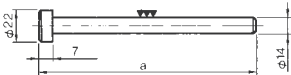

a									
100	125	150	175	200	250	300	350	400	600

Viti
Screws
Vises

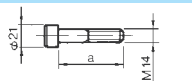

a									
25	30	35	40	45	50	55	60	70	80
90	100	110	120	130	140	150	160	180	200
220	240	260	280	300					

Serie X 296 x 296

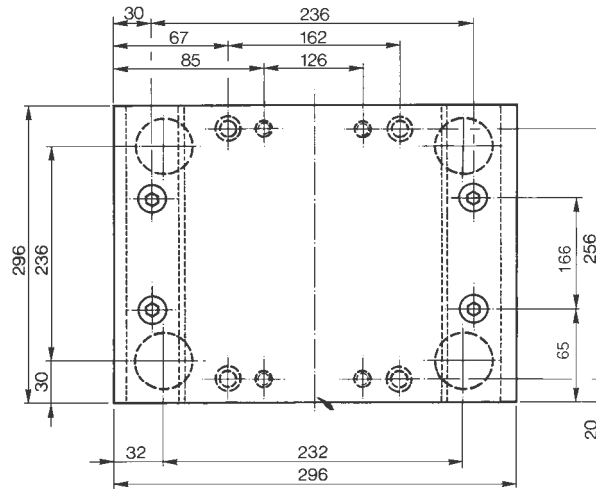
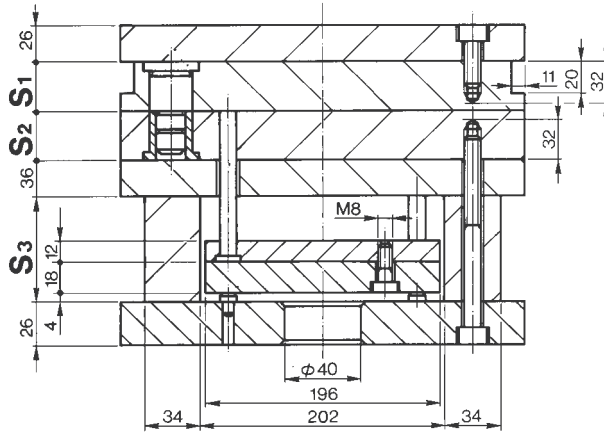

Serie X + M 296 x 296

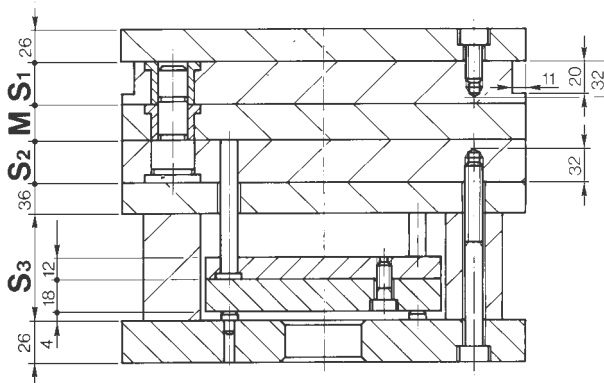

S ₁	S ₂	S ₃	M
36	36	57	36
46	46	77	46
56	56	97	56
66	66		66
76	76		76

Colonne di guida
Guide pins
Colonnes
Präzision Führungssäulen

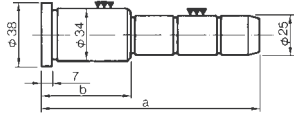

b	a												
80	90	100	120	140	160	180	200	220	240	260	280		
26													
36													
46													
56													
66													
76													
86													
96													

Bussole di guida
Bushes
Bagues
Führungsbuchse

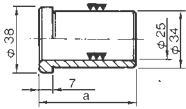

a							
26	36	46	56	66	76	86	96

Bussole di guida
Bushes
Bagues
Führungsbuchse

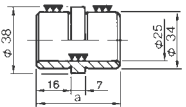

a	
32	40

Espulsori
Ejector
Ejecteurs
Auswerferstifte

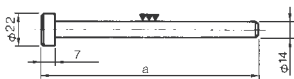

a									
100	125	150	175	200	250	300	350	400	600

Viti
Screws
Vises

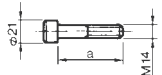

a									
25	30	35	40	45	50	55	60	70	80
90	100	110	120	130	140	150	160	180	200
220	240	260	280	300					

Serie X 296 x 346

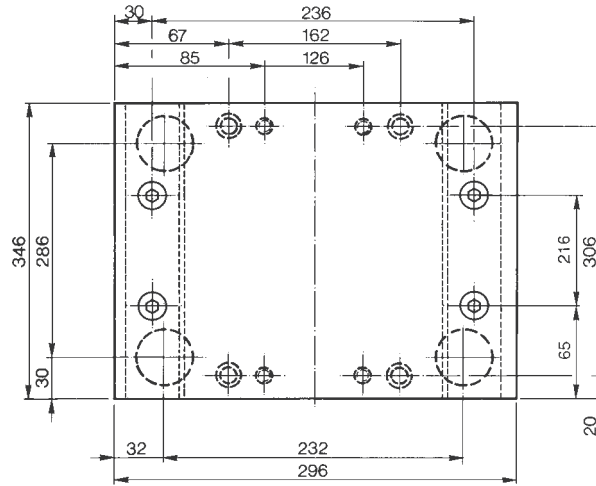
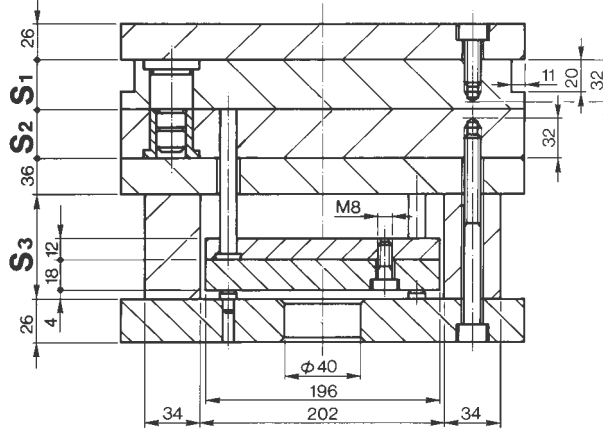

Serie X + M 296 x 346

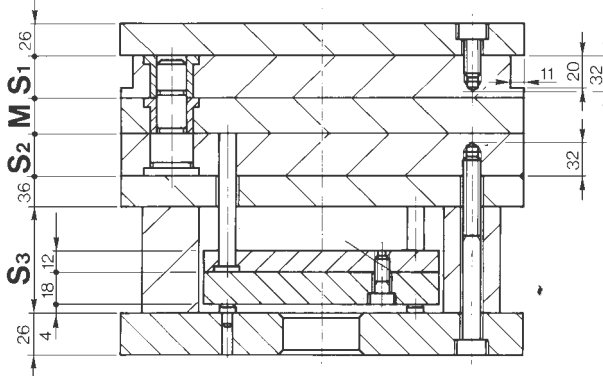

S ₁	S ₂	S ₃	M
36	36	57	36
46	46	77	46
56	56	97	56
66	66		66
76	76		76

Colonne di guida Guide pins Colonnes Präzision Führungssäulen

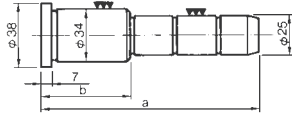

b	a											
80	90	100	120	140	160	180	200	220	240	260	280	
26												
36												
46												
56												
66												
76												
86												
96												

Bussole di guida Bushes Bagues Führungsbuchse

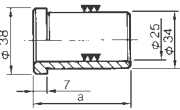

a							
26	36	46	56	66	76	86	96

Bussole di guida Bushes Bagues Führungsbuchse

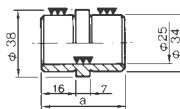

a	
32	40

Espulsori Ejector Éjecteurs Auswerferstifte

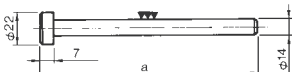

a							
100	125	150	175	200	250	300	350
400	600						

Viti Screws Vises

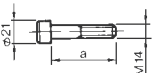

a											
25	30	35	40	45	50	55	60	70	80		
90	100	110	120	130	140	150	160	180	200		
220	240	260	280	300							

Serie X 296 x 396

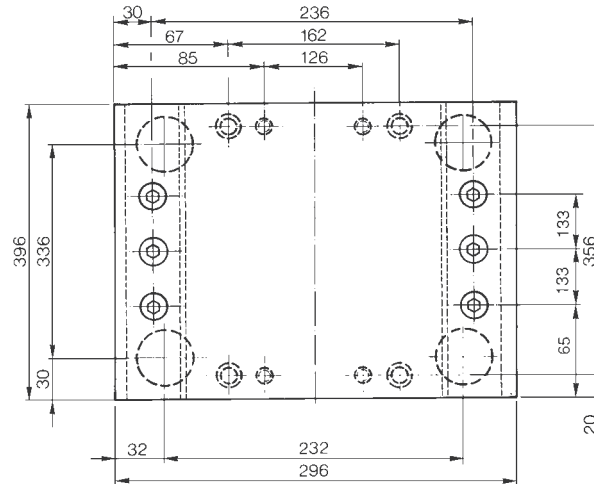
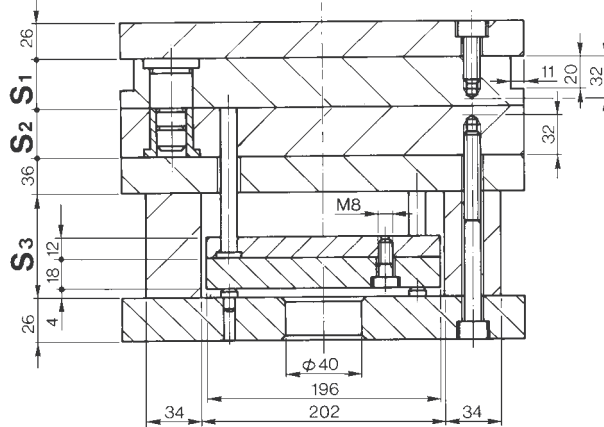

Serie X + M 296 x 396

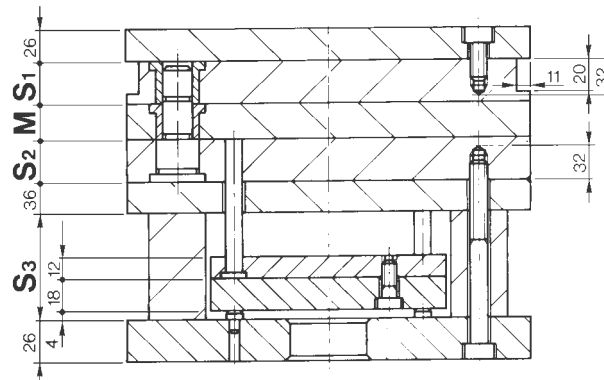

S ₁	S ₂	S ₃	M
36	36	57	36
46	46	77	46
56	56	97	56
66	66		66
76	76		76

Colonne di guida
Guide pins
Colonnes
Präzision Führungssäulen

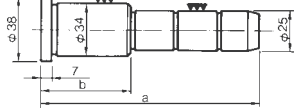

b	a												
80	90	100	120	140	160	180	200	220	240	260	280		
26													
36													
46													
56													
66													
76													
86													
96													

Bussole di guida
Bushes
Bagues
Führungsbuchse

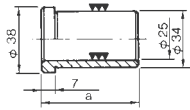

a							
26	36	46	56	66	76	86	96

Bussole di guida
Bushes
Bagues
Führungsbuchse

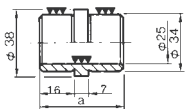

a	
32	40

Espulsori
Ejector
Ejecteurs
Auswerferstifte

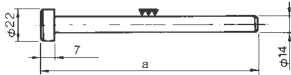

a									
100	125	150	175	200	250	300	350	400	600

Viti
Screws
Vises

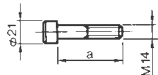

a									
25	30	35	40	45	50	55	60	70	80
90	100	110	120	130	140	150	160	180	200
220	240	260	280	300					

Serie X 296 x 446

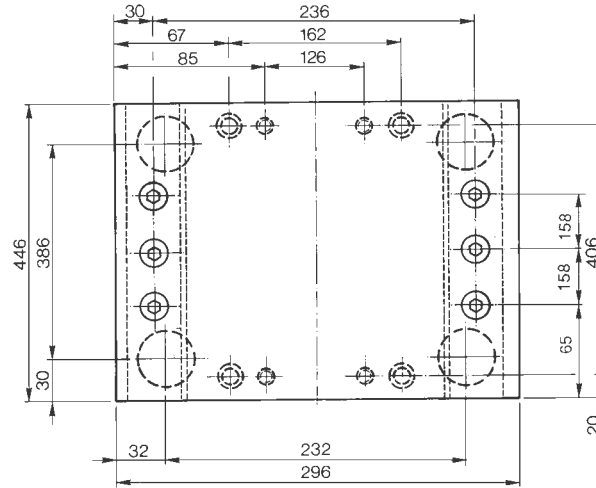
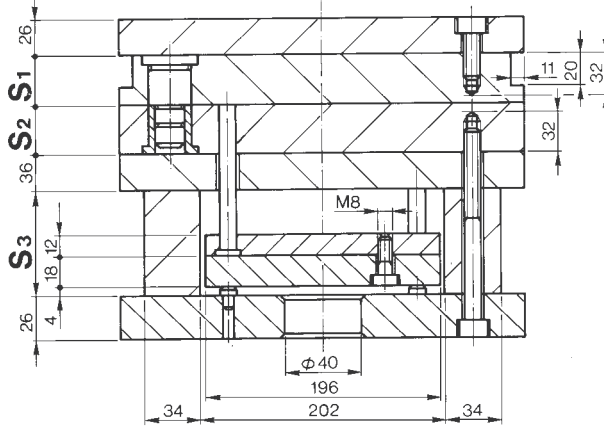

Serie X + M 296 x 446

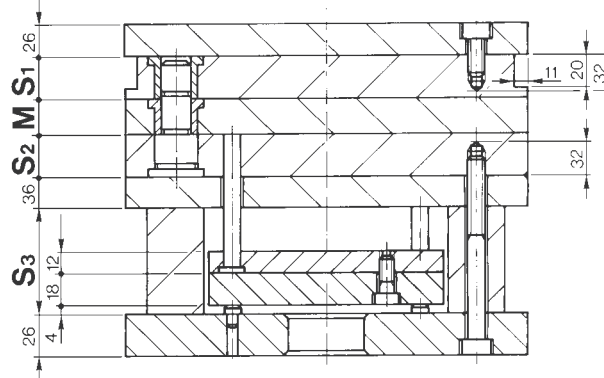

S ₁	S ₂	S ₃	M
36	36	57	36
46	46	77	46
56	56	97	56
66	66		66
76	76		76

Colonne di guida
Guide pins
Colonnes
Präzision Führungssäulen

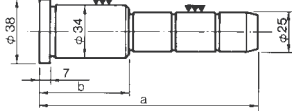

b	a																				
26	80	90	100	120	140	160	180	200	220	240	260	280									
36																					
46																					
56																					
66																					
76																					
86																					
96																					

Bussole di guida
Bushes
Bagues
Führungsbuchse

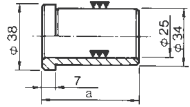

a							
26	36	46	56	66	76	86	96

Bussole di guida
Bushes
Bagues
Führungsbuchse

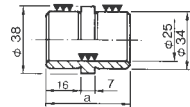

a	
32	40

Espulsori
Ejector
Ejecteurs
Auswerferstifte

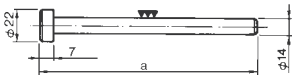

a									
100	125	150	175	200	250	300	350	400	600

Viti
Screws
Vises

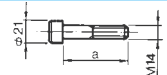

a									
25	30	35	40	45	50	55	60	70	80
90	100	110	120	130	140	150	160	180	200
220	240	260	280	300					

Serie X 346 x 346

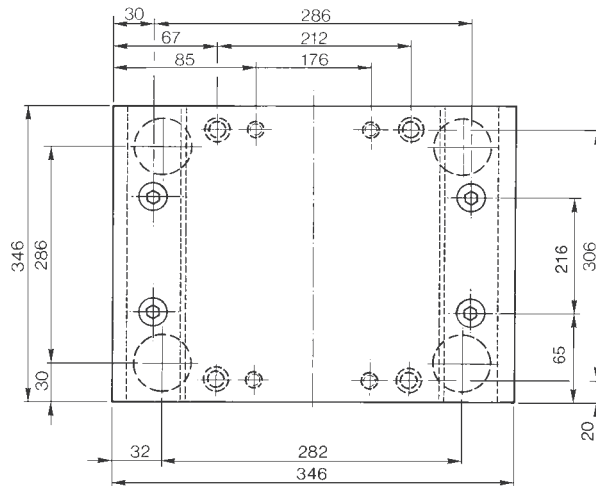
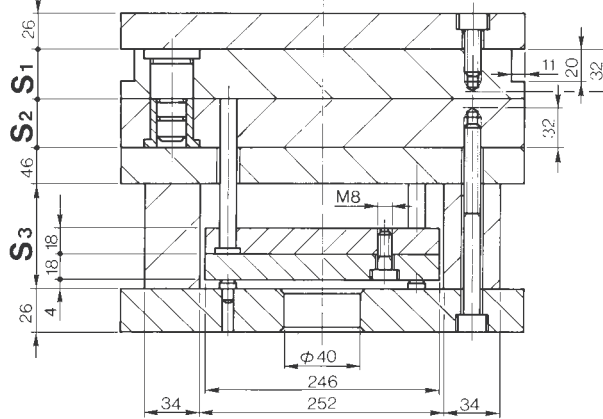

Serie X + M 346 x 346

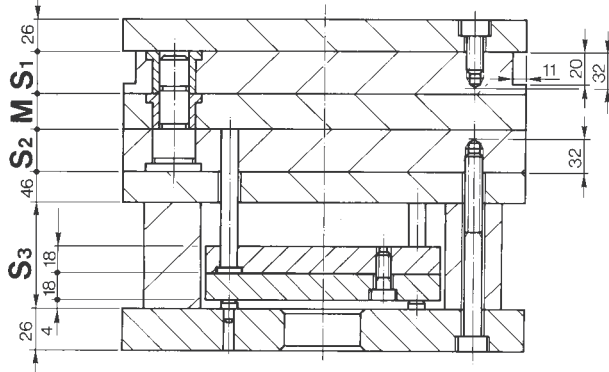

S ₁	S ₂	S ₃	M
46	46	57	46
56	56	77	56
66	66	97	66
76	76		76
96	96		96

Colonne di guida
Guide pins
Colonnes
Präzision Führungssäulen

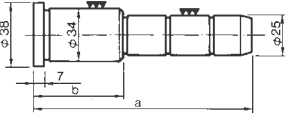

b	a										
80	90	100	120	140	160	180	200	220	240	260	280
26											
36											
46											
56											
66											
76											
86											
96											

Bussole di guida
Bushes
Bagues
Führungsbuchse

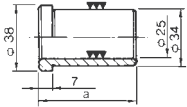

a							
26	36	46	56	66	76	86	96

Bussole di guida
Bushes
Bagues
Führungsbuchse

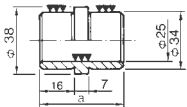

a	
32	40

Espulsori
Ejector
Éjecteurs
Auswerferstifte

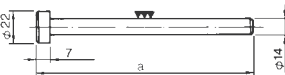

a									
100	125	150	175	200	250	300	350	400	600

Viti
Screws
Vises

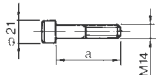

a										
25	30	35	40	45	50	55	60	70	80	
90	100	110	120	130	140	150	160	180	200	
220	240	260	280	300						

Serie X 346 x 396

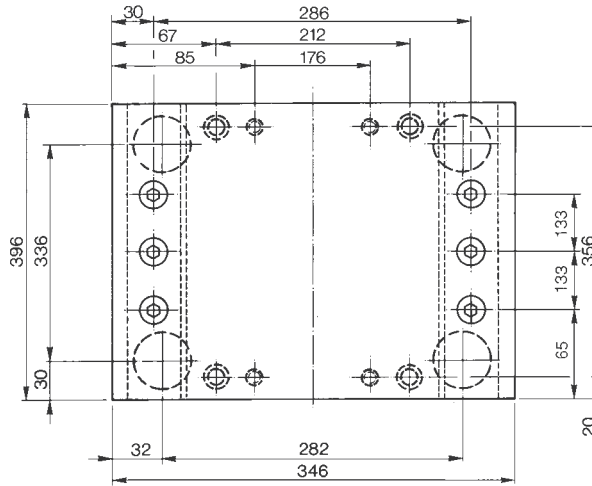
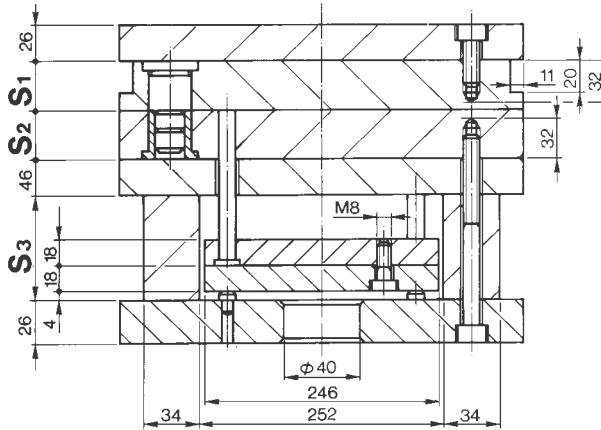

Serie X + M 346 x 396

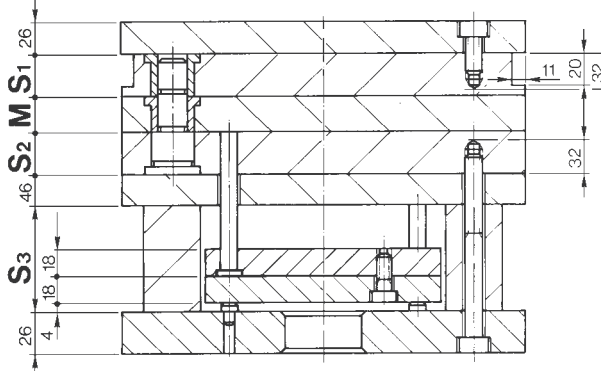

S ₁	S ₂	S ₃	M
46	46	57	46
56	56	77	56
66	66	97	66
76	76		76
96	96		96

Colonne di guida
Guide pins
Colonnes
Präzision Führungssäulen

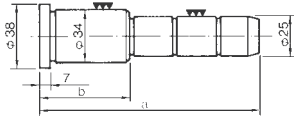

b	a											
26	80	90	100	120	140	160	180	200	220	240	260	280
36												
46												
56												
66												
76												
86												
96												

Bussole di guida
Bushes
Bagues
Führungsbuchse

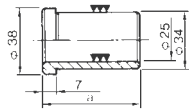

a							
26	36	46	56	66	76	86	96

Bussole di guida
Bushes
Bagues
Führungsbuchse

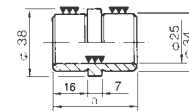

a	
32	40

Espulsori
Ejector
Éjecteurs
Auswerferstifte

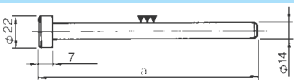

a									
100	125	150	175	200	250	300	350	400	600

Viti
Screws
Vises

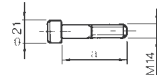

a										
25	30	35	40	45	50	55	60	70	80	
90	100	110	120	130	140	150	160	180	200	
220	240	260	280	300						

Serie X 346 x 446

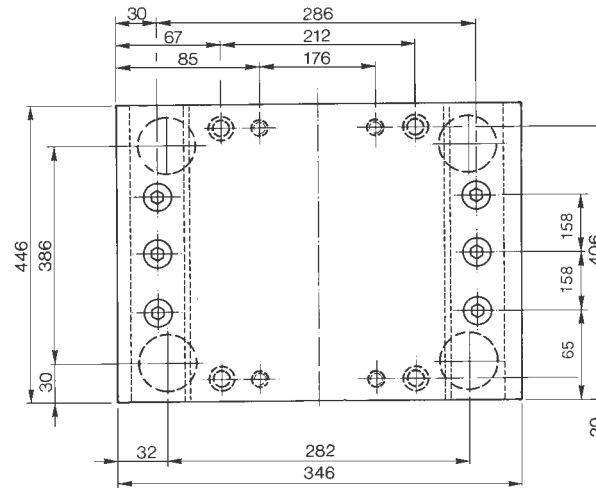
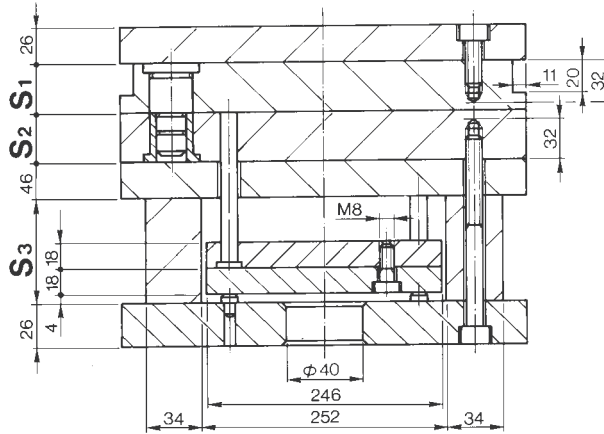

Serie X + M 346 x 446

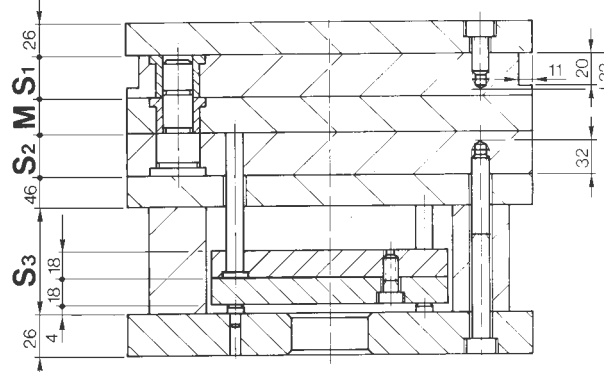

S ₁	S ₂	S ₃	M
46	46	57	46
56	56	77	56
66	66	97	66
76	76		76
96	96		96

Colonne di guida
Guide pins
Colonnes
Präzision Führungssäulen

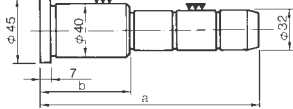

b	a															
36	80	90	100	120	140	160	180	200	220	240	260	280				
46																
56																
66																
76																
86																
96																
106																

Bussole di guida
Bushes
Bagues
Führungsbuchse

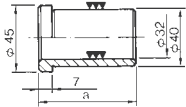

a							
36	46	56	66	76	86	96	106

Bussole di guida
Bushes
Bagues
Führungsbuchse

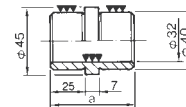

a	
50	65

Espulsori
Ejector
Ejecteurs
Auswerferstifte

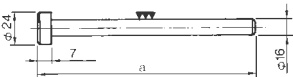

a									
100	125	150	175	200	250	300	350	400	600

Viti
Screws
Vises

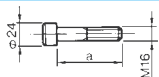

a									
25	30	35	40	45	50	55	60	70	80
90	100	110	120	130	140	150	160	180	200
220	240	260	280	300					

Serie X 396 x 396

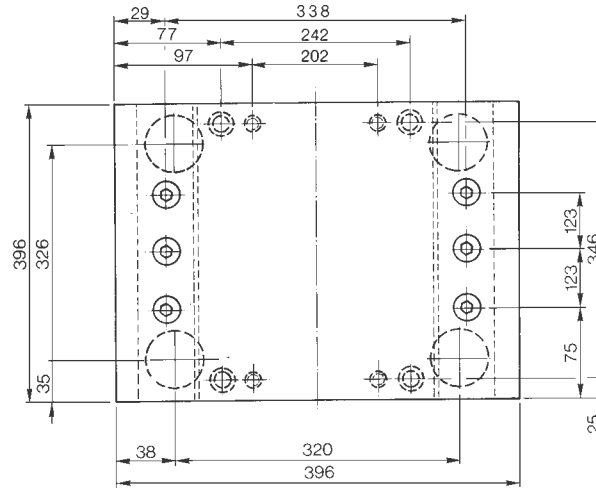
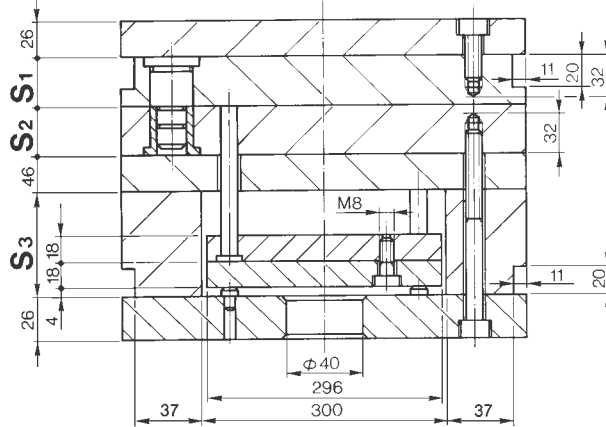

Serie X + M 396 x 396

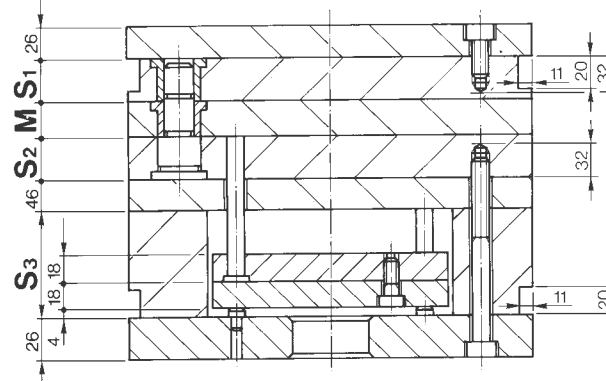

S ₁	S ₂	S ₃	M
46	46	57	46
56	56	77	56
66	66	97	66
76	76		76
96	96		96

Colonne di guida
Guide pins
Colonnes
Präzision Führungssäulen

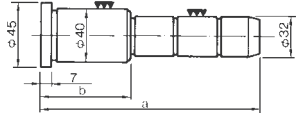

b	a										
80	90	100	120	140	160	180	200	220	240	260	280
36											
46											
56											
66											
76											
86											
96											
106											

Bussole di guida
Bushes
Bagues
Führungsbuchse

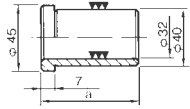

a							
36	46	56	66	76	86	96	106

Bussole di guida
Bushes
Bagues
Führungsbuchse

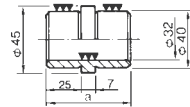

a	
50	65

Espulsori
Ejector
Éjecteurs
Auswerferstifte

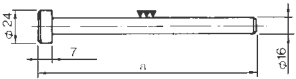

a									
100	125	150	175	200	250	300	350	400	600

Viti
Screws
Vises

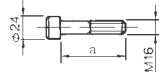

a									
25	30	35	40	45	50	55	60	70	80
90	100	110	120	130	140	150	160	180	200
220	240	260	280	300					

Serie X 396 x 446

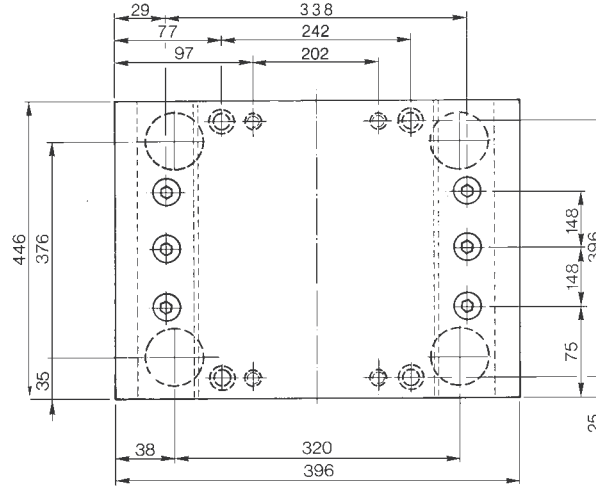
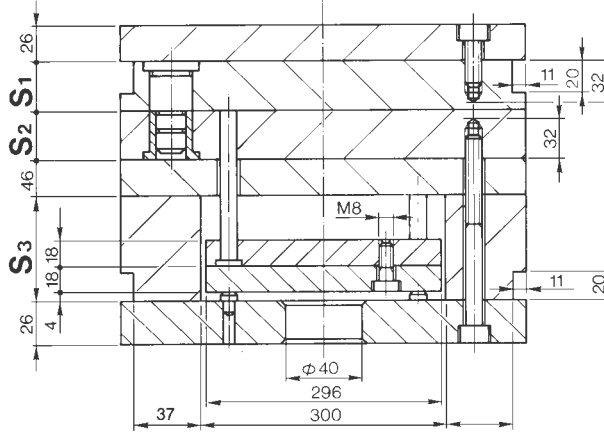

Serie X + M 396 x 446

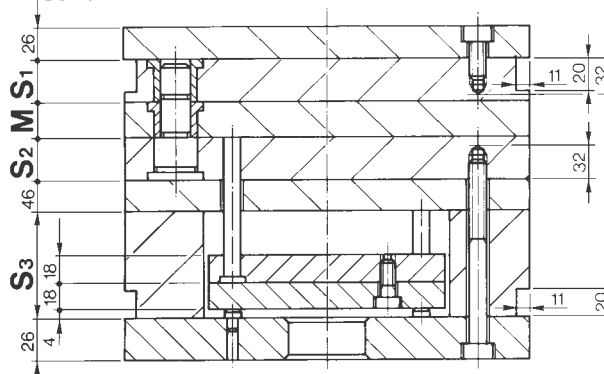

S ₁	S ₂	S ₃	M
46	46	57	46
56	56	77	56
66	66	97	66
76	76		76
96	96		96

Colonne di guida
Guide pins
Colonnes
Präzision Führungssäulen

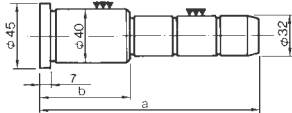

b	a														
80	90	100	120	140	160	180	200	220	240	260	280				
36															
46															
56															
66															
76															
86															
96															
106															

Bussole di guida
Bushes
Bagues
Führungsbuchse

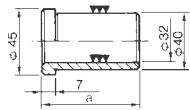

a							
36	46	56	66	76	86	96	106

Bussole di guida
Bushes
Bagues
Führungsbuchse

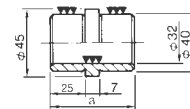

a	
50	65

Espulsori
Ejector
Éjecteurs
Auswerferstifte

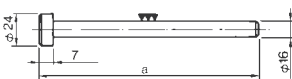

a									
100	125	150	175	200	250	300	350	400	600

Viti
Screws
Vises

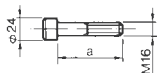

a									
25	30	35	40	45	50	55	60	70	80
90	100	110	120	130	140	150	160	180	200
220	240	260	280	300					

Serie X 396 x 496

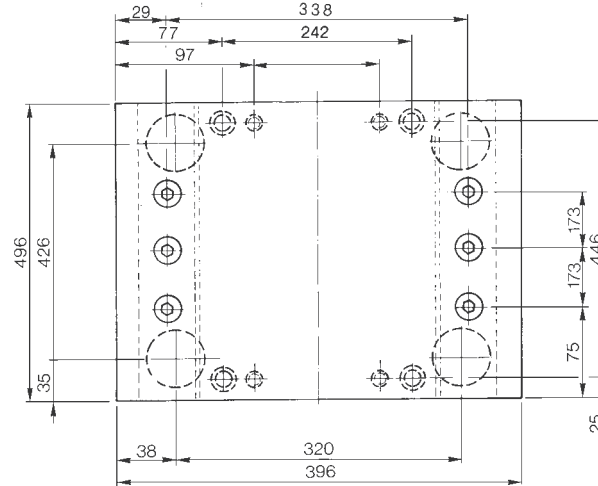
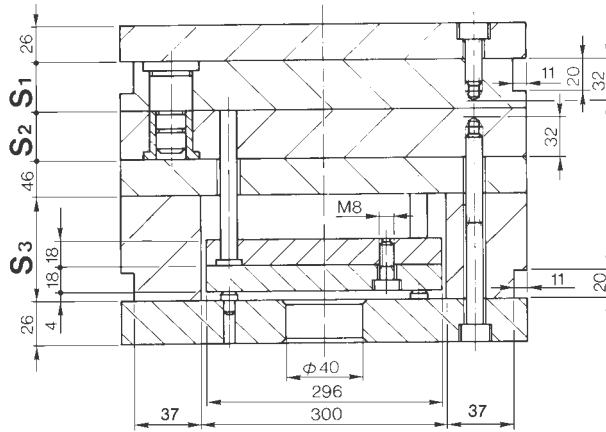

Serie X + M 396 x 496

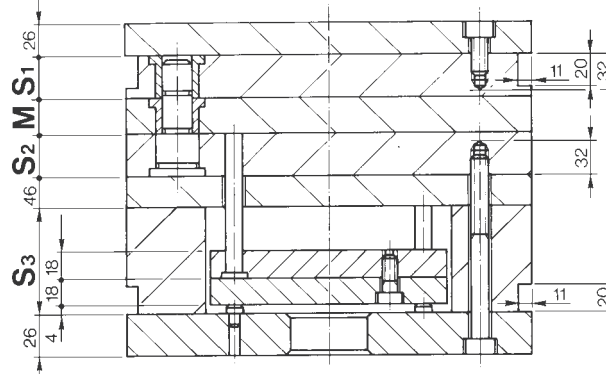

S ₁	S ₂	S ₃	M
46	46	57	46
56	56	77	56
66	66	97	66
76	76		76
96	96		96

Colonne di guida
Guide pins
Colonnes
Präzision Führungssäulen

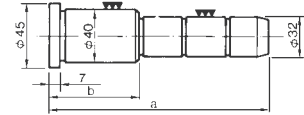

b	a										
80	90	100	120	140	160	180	200	220	240	260	280
36											
46											
56											
66											
76											
86											
96											
106											

Bussole di guida
Bushes
Bagues
Führungsbuchse

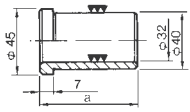

a							
36	46	56	66	76	86	96	106

Bussole di guida
Bushes
Bagues
Führungsbuchse

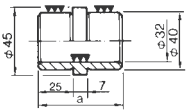

a	
50	65

Espulsori
Ejector
Éjecteurs
Auswerferstifte

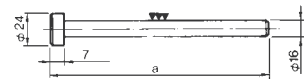

a									
100	125	150	175	200	250	300	350	400	600

Viti
Screws
Vises

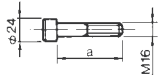

a									
25	30	35	40	45	50	55	60	70	80
90	100	110	120	130	140	150	160	180	200
220	240	260	280	300					

Serie X 396 x 546

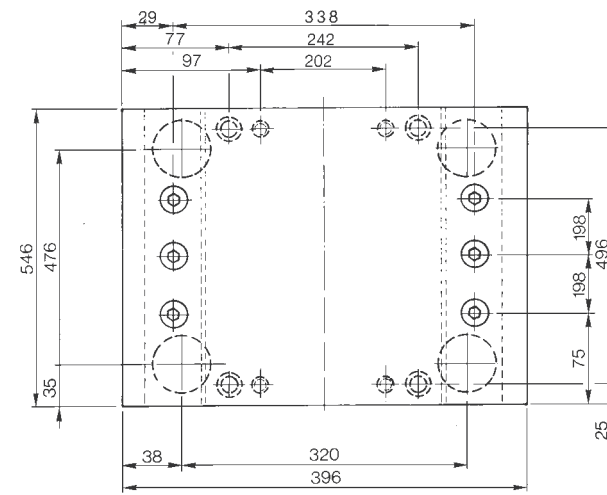
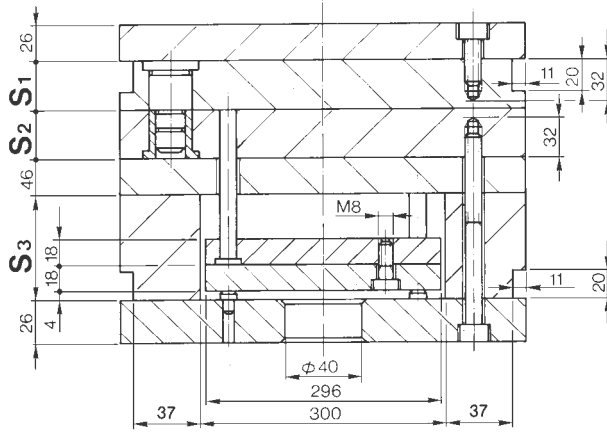

Serie X + M 396 x 546

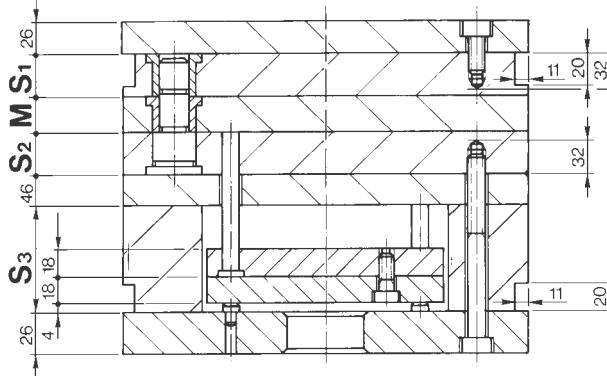

S ₁	S ₂	S ₃	M
46	46	57	46
56	56	77	56
66	66	97	66
76	76		76
96	96		96

Acciaio
Steel
Acier
Werkstoff

UNI 95M NvCR 5 KU
 DIN 1.2510 K460

Esecuzione
Finish
Exécution
Ausführung

Rettificato

Ground

Rectifiées

Geschliffen

Tolleranza

T = SPESORE -0/+0,05
 W = LARGHEZZA -0/+0,02

Trattamento da eseguire

Tempra:
 790-820°C spegnimento in olio a bagno di sale a 200-250°C (fino allo spessore massimo di 20 mm). Tempo di permanenza a temperatura: minimo 10 min. Per pezzi con spessore superiore a 20 mm è necessario 1-2 min per ogni mm di spessore. Durezza ottenibile: 63-65 HRC.

Rinvenimento:
 Deve essere effettuato in media temperatura dopo la tempra. I valori di durezza ottenibili dopo il rinvenimento si rilevano dalla corrispondente curva di rinvenimento. Tempo di permanenza a temperatura: minimo 1 ora. Per pezzi con spessore superiore a 20 mm è necessaria 1 ora per ogni 20 mm di spessore. In casi particolari può essere appropriato il trattamento ad una temperatura di rinvenimento lievemente inferiore con un tempo di permanenza lievemente superiore.

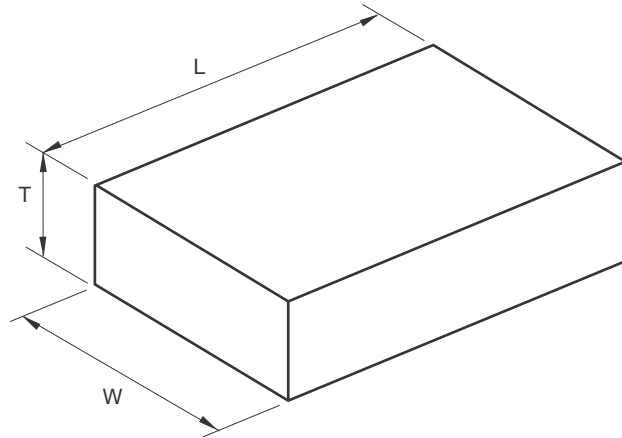

L	W larghezza	T = spessore														
		1	1,5	2	3	4	5	6	8	10	12	15	20	25	30	
500	4															
	5															
	6															
	8															
	10															
	12															
	15															
	20															
	25															
	30															
	35															
	40															
	50															
	60															
	70															
	80															
100																
125																
150																
200																
250																
300																

Piastre rettificate in acciaio indeformabile
Ground plates
Plaques rectifiées
Platten Geschliffen

BM
Industrie

Acciaio
Steel
Acier
Werkstoff

UNI X 15CR1M 0121
 DIn 1.2379-K110

Esecuzione
Finish
Exécution
Ausführung

Rettificato

Ground

Rectifiées

Geschliffen

Tolleranza

T = SPESORE -0/+0,05
 W = LARGHEZZA -0/+0,02

Trattamento da eseguire

Tempra:
 790-820°C spegnimento in olio a bagno di sale a 200-250°C (fino allo spessore massimo di 20 mm). Tempo di permanenza a temperatura: minimo 10 min. Per pezzi con spessore superiore a 20 mm è necessario 1-2 min per ogni mm di spessore. Durezza ottenibile: 63-65 HRC.

Rinvenimento:
 Deve essere effettuato immediatamente dopo la tempra. I valori di durezza ottenibili dopo il rinvenimento si rilevano dalla corrispondente curva di rinvenimento. Tempo di permanenza a temperatura: minimo 1 ora. Per pezzi con spessore superiore a 20 mm è necessaria 1 ora per ogni 20 mm di spessore. In casi particolari può essere appropriato il trattamento ad una temperatura di rinvenimento lievemente inferiore con un tempo di permanenza lievemente superiore.

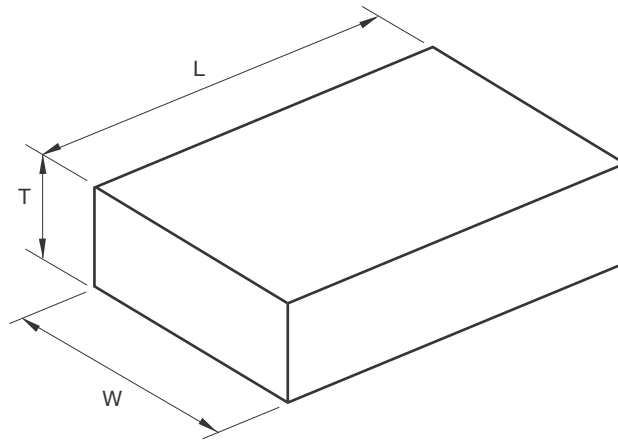

L	W larghezza	T = spessore														
		1	1,5	2,3	3,3	4,3	5,3	6,3	7,3	8,3	9,3	10,3	12,3	15,3	20,3	25,3
500	5,3															
	6,3															
	7,3															
	8,3															
	9,3															
	10,3															
	12,3															
	15,3															
	20,3															
	25,3															
	30,3															
	40,3															
	50,3															
	60,3															
	70,3															
	80,3															
100,3																
125,3																
150,3																
200,3																
250,3																

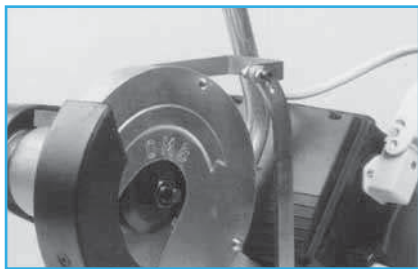
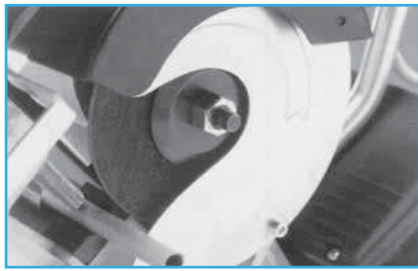

Senaggo pneumático
 Pneumatic clamping
 Senage pneumática

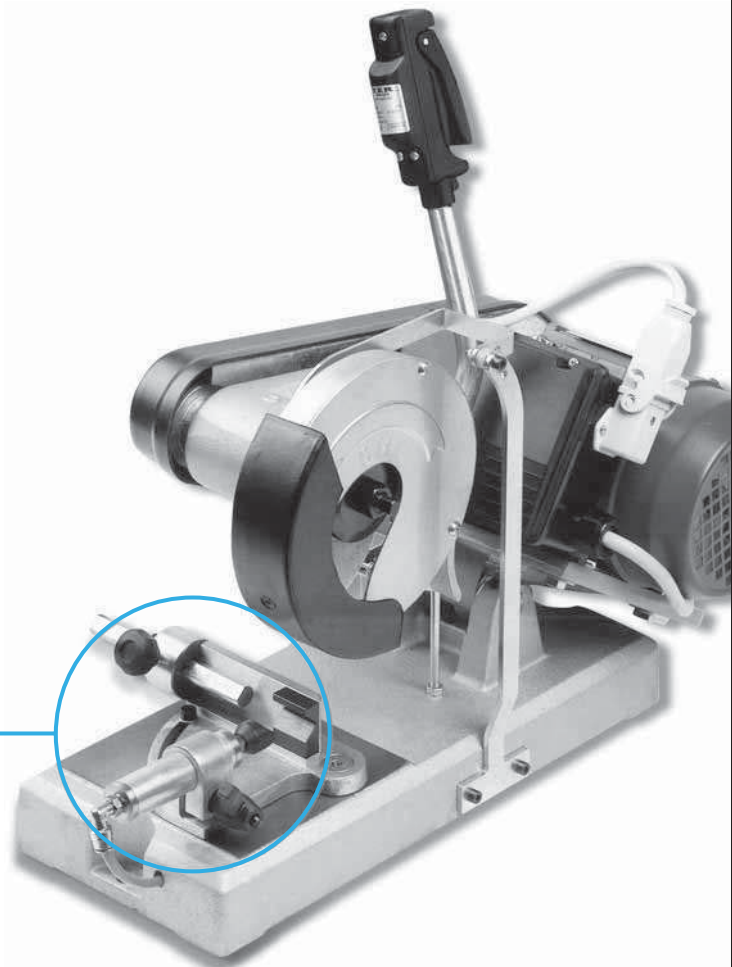

Serie DIAMANTE ARIA per piccole serie

Un nuovo gruppo morsa con pistone pneumatico, è stato creato per il taglio di componenti in piccole serie. Tramite la vite di regolazione si posiziona il corpo pistone in prossimità del pezzo da tagliare, l'azionamento della morsa viene comandato da un interruttore che, all'abbassarsi del disco abrasivo, comanda la chiusura del pistone. Particolarmente adatta per tagliare spine, punzoni, cobbe e bocche guida, barrette in acciaio, cobalto, profilati speciali in acciaio inox, alluminio, ottone, rame, niobio, ecc... Non lascia bavure e non altera il trattamento termico, motore 1HP/0.75kW, alimentazione trifase 380V, a richiesta anche alimentazione monofase 220V per hobbisti. Disco abrasivo per alte velocità Ø 150 x 1-1,5 mm, velocità di rotazione 6.000 giri circa, morsa graduata per tagli fino a 45°. Comanda di avviamento nell'impugnatura mediante micro-interruttore a bassa tensione, carter avvolgente per protezione totale disco abrasivo.

DIAMANTE ARIA range for small production series

The new chuck unit with pneumatic piston was designed to cut small series of components. The piston unit is aligned against the workpiece with the adjusting screw and the clamping jaws are operated by a switch which, when the abrasive disk is lowered, closes the piston. It is ideal for cutting pins, punches, pistons and guide bushings, cobalt steel bars, special stainless steel, aluminium, brass, copper, and niobium etc sections. It does not leave burr nor alter quench hardening treatment, 1HP/0.75kW motor, three-phase power supply, single 220V power unit available on request for home users. Abrasive disk Ø 150 x 1-1.5 mm, for high speeds, rotation speed approx. 6.000 rpm, rotating graduated chuck for cuts up to 45°. Starts using low voltage micro-switch on handle, wrap-around safety guard totally shields abrasive disk.

Serie DIAMANTE ARIA pour petites séries

Le nouveau groupe Øtau piston pneumatique a été spécialement conçu pour la coupe d'éléments fabriqués en petite série. Une vis de réglage permet de positionner le corps du piston proximo de la pièce à découper. Le fonctionnement de Øtau est donné par un interrupteur qui commande la fermeture du piston au moment où le disque abrasif s'abaisse. Machine particulièrement indiquée pour découper les chevilles, poinçons, cobbes et bagues de guidage, barrettes en acier au cobalt, profilés spéciaux en acier inox, aluminium, étain, cuivre, niobium etc. Ne laisse aucune trace de bavure et n'altère pas le traitement de trempe. Moteur 1 ch./0.75 kW, alimentation triphasée 380 V (sur demande, alimentation monophasée 220 V pour travaux de bricolage). Disque abrasif pour grandes vitesses Ø 150 x 1-1,5 mm, vitesse de rotation 6.000 tours environ, Øtau rotatif gradué pour coupes jusqu'à 45°. Comande de démarrage sur la poignée par micro-interrupteur basse tension, carter enveloppant pour protection totale du disque abrasif.

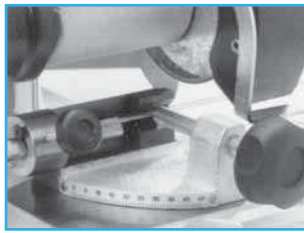

Serie DIAMANTE ABZ

Particolare adatta per tagliare spine, punzoni, colonne e boccole guida, bazzette in acciaio al cobalto, profilati speciali in acciaio inox, alluminio, ottone, rame e nylon, ecc...

Non lascia bave e non altera il trattamento di tempra, motore 1HP/0.75kW, alimentazione trifase 380V, a richiesta anche alimentazione monofase 220V per hobbisti.

Disco abrasivo per alte velocità Ø 150 x 1-1,5 mm, velocità di rotazione 6.000 giri circa in orsa girevole graduata per tagli fino a 45°. Comando di avviamento nell'impugnatura mediante micro-interruttore a bassa tensione, catter avvolgente per protezione totale disco abrasivo.

DIAMANTE ABZ range

It is ideal for cutting pins, punches, pilot pins and guide bushings, cobalt steel bars, special stainless steel, aluminium, brass, copper and nylon etc sections.

It does not leave burr nor alter quench hardening treatment, 1HP/0.75kW motor, three-phase power supply, single 220V power unit available on request for home users.

Abrasive disk Ø 150 x 1-1,5 mm, for high speeds, rotation speed approx. 6.000 rpm, rotating graduated chuck for cuts of up to 45°. Starts using low voltage micro-switch on handle, wrap-around safety guard totally shields abrasive disk.

Série DIAMANTE ABZ

Machine particulièrement indiquée pour découper les chevilles poinçons, colonnes et bagues de guidage, bazzettes en acier au cobalt, profilés spéciaux en acier-inox, aluminium, laiton, cuivre, nylon etc.

Ne laisse aucune trace de bavure et n'altère pas le traitement de tempra. Moteur 1 ch./0.75 kW, alimentation triphasée 380 V (sur demande, alimentation monophasée 220 V pour travaux de bricolage).

Disque abrasif pour grandes vitesses Ø 150 x 1-1,5 mm, vitesse de rotation 6.000 tours environ, étai rotatif gradué pour coupes jusqu'à 45°.

Comande de démarrage sur la poignée par micro-interrupteur basse tension, catter enveloppant pour protection totale du disque abrasif.

Caratteristiche generali
General features

Il supporto antivibrante VIBRO-LEVEL è stato appositamente studiato per risolvere ogni problema di installazione rapida o di spostamenti di un parco macchine per esigenze di produzione o di spazio, offrendo i seguenti vantaggi:

- Semplice posa in opera della macchina in bolla
- Livellamento preciso, avvitando il tirante il supporto si ingrossa
- Ammortizzamento di vibrazioni e urti su gomma antiscivolo
- Possibilità di un rapido spostamento della macchina senza bisogno di fondazioni.

The antivibrations mountings VIBROLEVEL have been studied to solve all problems of a fast displacement for the needs of production and space;

These supports offer the following advantages:

- Exact levelling
- Endurance against vibrations and knocks
- Possibility of a fast displacement of the engine without foundations.

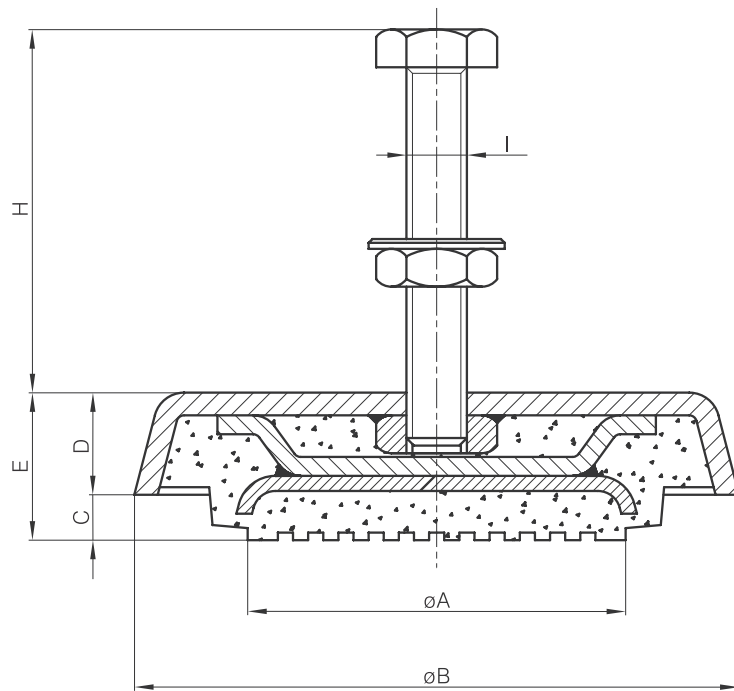

Tipo	A	B	C	D	E	H	I	Carico Max
OG-120	75	120	12	24	36	75	M-12	1000 Kg.
OG-140	110	140	14	28	42	100	M-14	2000 Kg.
OG-180	120	180	16	33	49	100	M-16	3000 Kg.
OG-230	160	230	19	38	57	135	M-18	4000 Kg.

Caratteristiche generali General features

Il supporto antivibrante VIBRO-TAP è stato studiato per risolvere i problemi di quelle installazioni nelle quali non sia necessario il livellamento (esempio A), o nel caso di livellamenti in cui non sia indispensabile la rigidità della macchina (esempio B).

La sua forma e struttura garantisce i seguenti vantaggi:

- Perfetta aderenza al pavimento e sicuro ancoraggio della macchina
- Isolamento alle vibrazioni assorbendo gli urti ed eliminando i rumori di funzionamento.
- Durata illimitata della gomma essendo in neoprene antiolio
- Semplice posa in opera della macchina in bolla (es. B)
- Possibilità di un rapido spostamento della macchina senza bisogno di fondazioni.

The antivibrations mountings VIBRO-TAP have been studied to solve the problems for the engine where the levelling is not necessary (A), or for the levelling where the rigidity of the engine is not important (B).

The shape of this support guarantees the following advantages:

- Perfect adherence to the floor
- Isolation against vibrations and elimination of working noise
- Unlimited rubber resistance
- Possibility of a fast displacement of the engine without foundations.

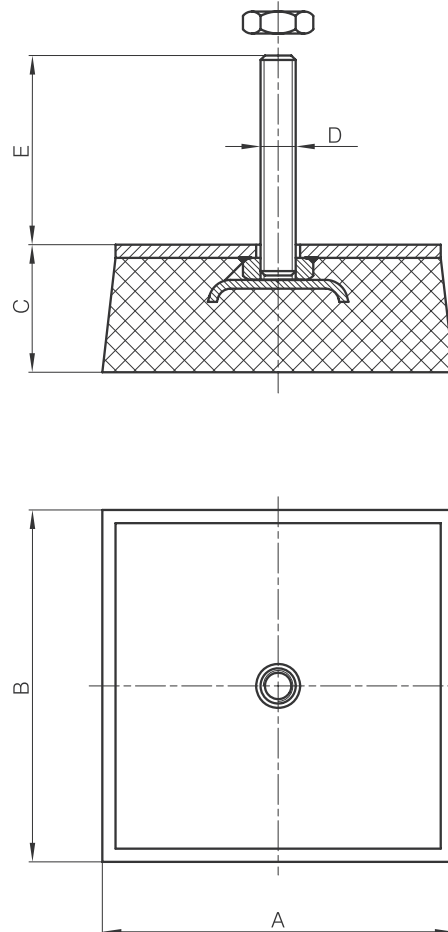

Tipo	A	B	C	D	E	Carico Max
OM 80	80	50	20	M 8	50	356 Kg.
OM 110	110	70	22	M 12	60	700 Kg.
OM 150	150	100	25	M 16	70	1800 Kg.
OM 200	200	120	30	M 18	80	3000 Kg.

Tabella Tolleranze
Tolerances
Tolerances
Abmaße

Ø EST - Ø E T - A EN A E - in µm 0,001mm

mm	f6	f7	g6	h3	h4	h5	h6	h8	h9	j6	js6	js9	js14	js15	k6	m5	m6	n6
DA 1	-6	-6	-2	0	0	0	0	0	0	+4	+3	+12,5	+125	+200	+6	+6	+8	+10
A 3	-12	-16	-8	-2	-3	-4	-6	-14	-25	-2	-3	-12,5	-125	-200	0	+2	+2	+4
OLTæ 3	-10	-10	-4	0	0	0	0	0	0	+6	+4	+15	+150	+240	+9	+9	+12	+16
A 6	-18	-22	-12	-2,5	-4	-5	-8	-18	-30	-2	-4	-15	-150	-240	+1	+4	+4	+8
OLTæ 6	-13	-13	-5	0	0	0	0	0	0	+7	+4,5	+18	+180	+290	+10	+12	+15	+19
A 10	-22	-28	-14	-2,5	-4	-6	-9	-22	-36	-2	-4,5	-18	-180	-290	+1	+6	+6	+10
OLTæ 10	-16	-16	-6	0	0	0	0	0	0	-8	+5,5	+21,5	+215	+350	+12	+15	+18	+23
A 18	-27	-34	-17	-3	-5	-8	-11	-27	-43	-3	-5,5	-21,5	-215	-350	+1	+7	+7	+12
OLTæ 18	-20	-20	-7	0	0	0	0	0	0	+9	+6,5	+26	+260	+420	+12	+17	+21	+28
A 30	-33	-41	-20	-4	-6	-9	-13	-33	-52	-4	-6,5	-26	-260	-420	+2	+8	+8	+15
OLTæ 30	-25	-25	-9	0	0	0	0	0	0	+11	+8	+31	+310	+500	+18	+20	+25	+33
A 50	-41	-50	-25	-4	-7	-11	-16	-39	-62	-5	-8	-31	-310	-500	+2	+9	+9	+17
OLTæ 50	-30	-30	-10	0	0	0	0	0	0	+12	+9,5	+37	+370	+600	+21	+24	+30	+39
A 80	-49	-60	-29	-5	-8	-13	-19	-46	-74	-7	-9,5	-37	-370	-600	+2	+11	+11	+20
OLTæ 80	-36	-36	-12	0	0	0	0	0	0	+13	+11	+43,5	+435	+700	+25	+28	+35	+45
A 120	-58	-71	-34	-6	-10	-15	-22	-54	-87	-9	-11	-43,5	-435	-700	+3	+13	+13	+23

Ø INT - Ø INT - INNEN A E - in µm 0,001mm

mm	E8	F7	G7	H5	H6	H7	H8	H9	H10	H11	J7	JS5	K6	K7	M6	M7	P6	P7
DA 1	+28	+16	+12	+4	+6	+10	+14	+25	+40	+60	+4	+2	0	0	-2	-2	-6	-6
A 3	+14	+6	+2	0	0	0	0	0	0	0	-6	-2	-6	-10	-8	-12	-12	-16
OLTæ 3	+38	+22	+16	+5	+8	+12	+18	+30	+48	+75	+6	+2,5	+2	+3	-1	0	-9	-8
A 6	+20	+10	+4	0	0	0	0	0	0	0	-6	-2,5	-6	-9	-9	-12	-17	-20
OLTæ 6	+47	+28	+20	+6	+9	+15	+22	+36	+58	+90	+8	+3	+2	+5	-3	0	-12	-9
A 10	+25	+13	+5	0	0	0	0	0	0	0	-7	-3	-7	-10	-12	-15	-21	-24
OLTæ 10	+59	+34	+24	+8	+11	+18	+27	+43	+70	+110	+10	+4	+2	+6	-4	0	-18	-14
A 18	+32	+16	+6	0	0	0	0	0	0	0	-8	-4	-9	-12	-15	-18	-26	-29
OLTæ 18	+73	+41	+28	+9	+13	+21	+33	+52	+84	+130	+12	+4,5	+2	+6	-4	0	-18	-14
A 30	+40	+20	+7	0	0	0	0	0	0	0	-9	-4,5	-11	-15	-17	-21	-31	-35
OLTæ 30	+89	+50	+34	+11	+16	+25	+39	+62	+100	+160	+14	+5,5	+3	+7	-4	0	-21	-17
A 50	+50	+25	+9	0	0	0	0	0	0	0	-11	-5,5	-13	-18	-20	-25	-37	-42
OLTæ 50	+106	+60	+40	+13	+19	+30	+46	+74	+120	+190	+18	+6,5	+4	+9	-5	0	-26	-21
A 80	+60	+30	+10	0	0	0	0	0	0	0	-12	-6,5	-15	-21	-24	-30	-45	-51
OLTæ 80	+126	+71	+47	+15	+22	+35	+54	+87	+140	+220	+22	+7,5	+4	+10	-6	0	-30	-24
A 120	+72	+36	+12	0	0	0	0	0	0	0	-13	-7,5	-18	-25	-28	-35	-52	-59

BM Industrie

Via AURORA 12/E 3 PADRNO
DUGNANO .20037 -MILANO-ITALY
TEL 00393357158899- fax 0039029105268

E.MAIL : bmindustrie@libero.it